

User's Manual

M-Series **Analogue/PWM Tester** Magnetostrictive Linear Position Sensors

Document Part No.
551132 Revision B



Content

1 The M-Series analogue/PWM Test Kit

- 1.1 Contents and accessories
- 1.2 Familiarizing yourself with the M-Series Tester
 - 1.2.1 Front panel
 - 1.2.2 Top panel

2 Installation

- 2.1 Connecting analogue sensors
- 2.2 Connecting PWM sensors
- 2.3 Battery charger setup
- 2.4 AC power plug
- 2.5 Quick start instruction label
- 2.6 Carrier handle adjustment

3 Operation

- 3.1 Startup
- 3.2 Mode selection
 - 3.2.1 Voltage (Volt)
 - 3.2.2 Current (Curr)
 - 3.2.3 Battery level (Batt)
 - 3.2.4 Battery charging
 - 3.2.5 Scaled PWM (Puum)
 - 3.2.6 PWM time of flight (TOF)
- 3.3 Verification
- 3.4 Troubleshooting

1. The M-Series analogue/PWM Test Kit

The M-Series analogue/PWM Tester supports analogue, 0 - 20 mA and 0 - 10 Vdc, scaled Pulse Width Modulated (PWM), and PWM time of flight (tof) sensor outputs. The M-Series Tester is a battery powered device that can be used in test bench and field applications to verify that the MTS Sensor is functioning properly and is producing the appropriate signal outputs.

- Easy connection to MTS' M12 integrated connector system
- Easy to use push-button controls
- Supports voltage (0-10 Vdc) and current (0-20 mA) outputs
- Tolerances 5 Vdc – 10 mV, 20 mA – 0,02 mA
- Supports scaled PWM and time-of-flight PWM outputs
- Compact construction for use in field applications
- Provides both +5 Vdc and +12/24 Vdc sensor power supply
- Battery that provides up to 8 hours of operation per charge
- Battery level monitoring
- Automatic detection of PWM sensor frequency
- Carrying case

1.1 Content and Accessories

The M-Series analogue/PWM Test Kit includes:

1. M-Series analogue/PWM Tester (254 025)
2. 12 VDC battery charger with adapter EU/UK (380 090)
3. Cable with MTS' M12*1 integrated connector system and banana plugs pin 2-3-4 (253 869) for pin assignment E
4. Cable with MTS M12*1 integrated connector system and banana plugs pin 1-3-4, pin 1-3-2 (254 204) for pin assignment G and H
5. Pigtailed cables with banana plugs (253 870) (not pictured)
6. Carrying case (590 138)
7. User's Guide (not pictured)
7. Quick start instruction label (not pictured)

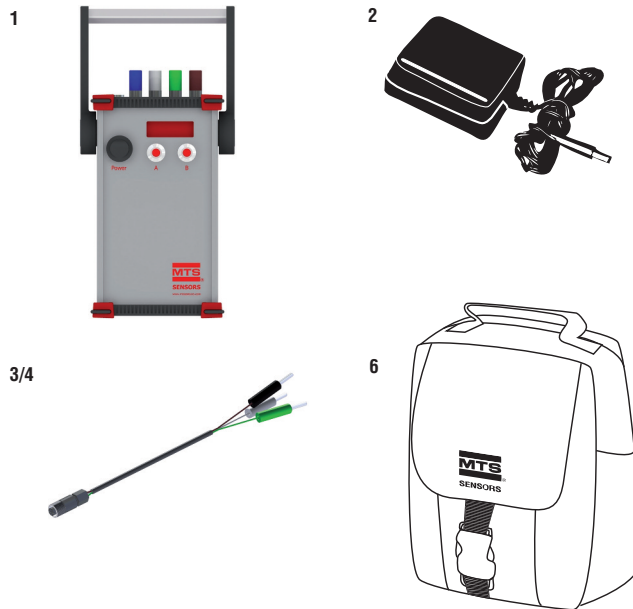

Accessories

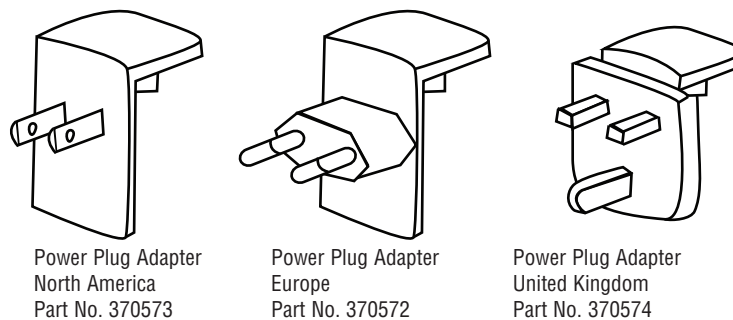

1. The M-Series analogue/PWM Test Kit (continued)

1.2 Familiarizing yourself with the M-Series Tester

1.2.1 Front panel

1. **LCD panel**
Tester LCD panel displays sensor output, settings, and battery level
2. **Power switch**
Toggle to turn the M-Series Tester 'ON' and 'OFF'.
3. **Mode button (A)**
Press to change transducer modes and to reset system.
4. **Special function button (B)**
Press to change recirculation values in PWM TOF mode

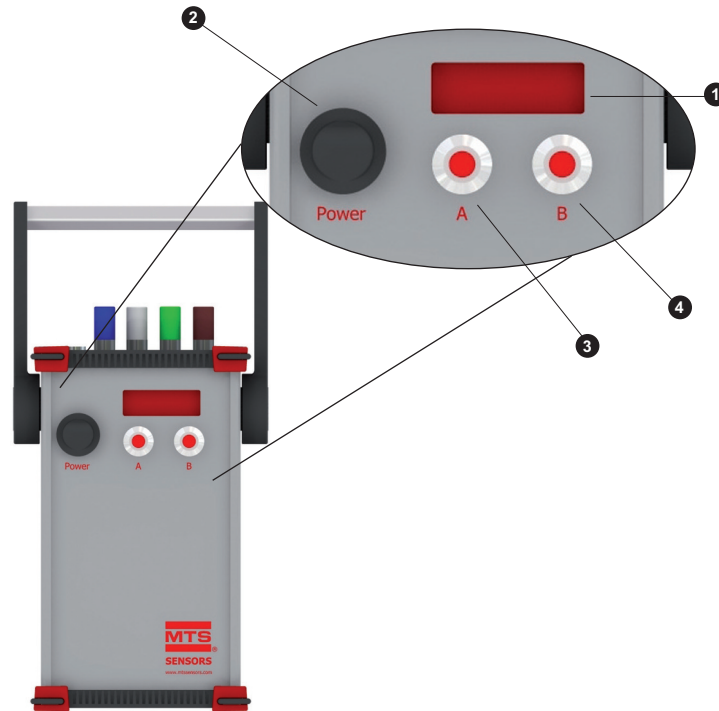

1.2.2 Top Panel

1. **Charger port**
Port used to charge the battery
2. **+5 V**
Sensor 5 volt supply connection (Not an input port)
3. **+12 V**
Sensor 12 volt supply connection (Not an input port)
4. **GND**
Sensor ground connection.
5. **ANA**
Connection for sensors with analogue output signal.
6. **PWM**
Connection for sensors with PWM/TOF output signal.

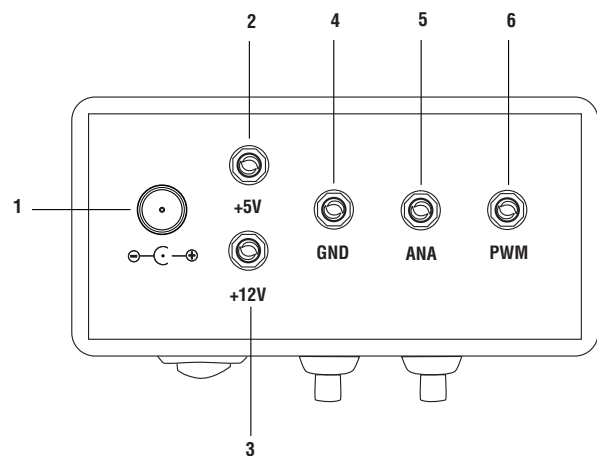

2. Installation

2.1 Connecting an analogue Sensor

To connect an analogue sensor equipped with MTS' M12 integrated connector system to the M-Series Tester use the following procedure:

1. Use the provided cabling fitted with the M12 connector and connect the M12 cable to the MTS M12 integrated connector system on the sensor or cylinder.
Please pay attention to the pin assignment of the sensors. Sensors with pin assignment 2-3-4 (e.g. N10E) have to be connected with the M12*1 cable with the connector colours brown, white and green. For sensors with pin assignment 1-2-3 (N10H) or 1-3-4 (N10G) please use the cable with the connector colours black, white and green.
(continue with step 3 below) OR

To connect an analogue sensor not equipped with MTS' M12 integrated connector system:

1. Use the Pigtailed cable that is included in the test kit to connect the ends without banana plugs to the customer's specified interface/connector that mates to the M-Series sensor or cylinder.
2. Ensure that the wire colors of the cable correspond with the wire colors of the output wires from the sensor.
3. Plug the brown banana plug into the +12 Vdc or +5 Vdc (depending on voltage required by the sensor) terminal on the top of the tester.
4. Plug the white banana plug into the DC GND terminal on the top of the tester.
5. Plug the green banana plug into the analog terminal at the top of the tester.

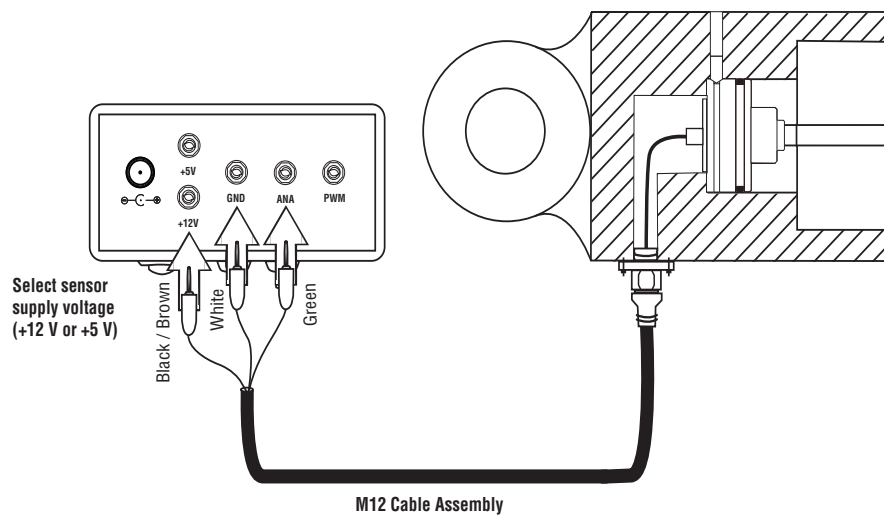

Attention! Please take care of the sensor type.

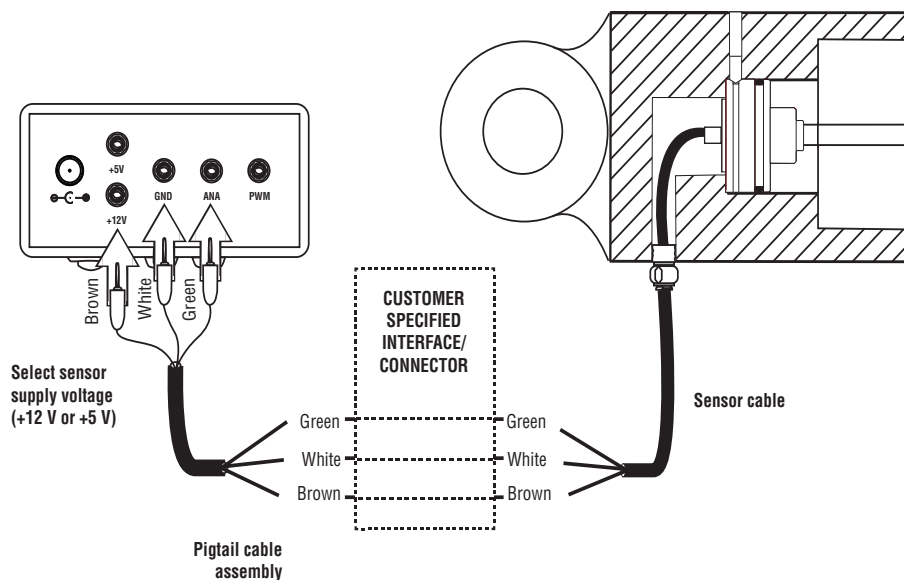

2. Installation (continued)

2.2 Connecting PWM Sensors

To connect a PWM sensor equipped with MTS' M12 integrated connector system to the M-Series Tester use the following procedure:

1. Use the provided cabling fitted with the M12 connector and connect the M12 cable to the MTS M12 integrated connector system on the sensor or cylinder.
(continue with step 3 below) OR

To connect a PWM sensor not equipped with MTS' M12 integrated connector system:

1. Use the Pigtailed cable that is included in the test kit to connect the ends without banana plugs to the customer's specified interface/connector that mates to the M-Series sensor or cylinder.
2. Ensure that the wire colors of the cable correspond with the wire colors of the output wires from the sensor.
3. Plug the brown banana plug into the +12 Vdc or +5 Vdc (depending on voltage required by the sensor) terminal on the top of the tester.
4. Plug the white banana plug into the DC GND terminal on the top of the tester.
5. Plug the green banana plug into the PWM terminal at the top of the tester.

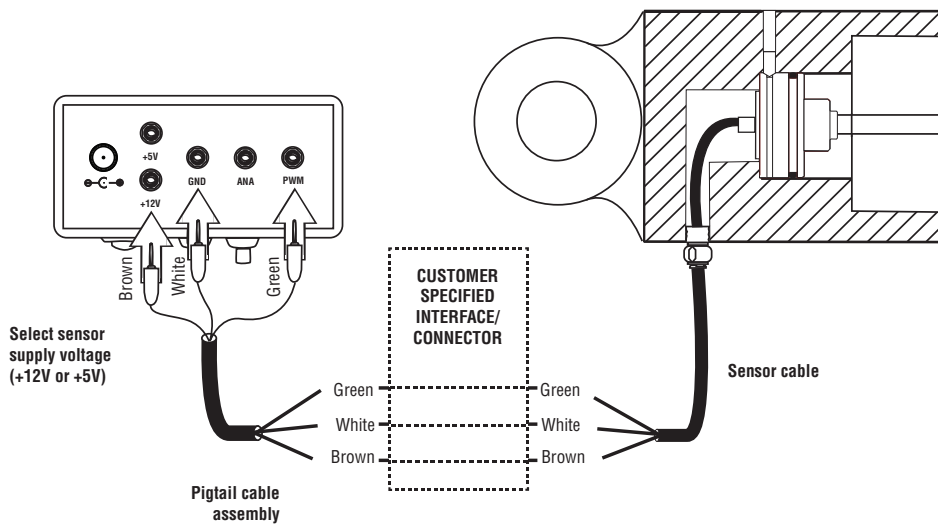
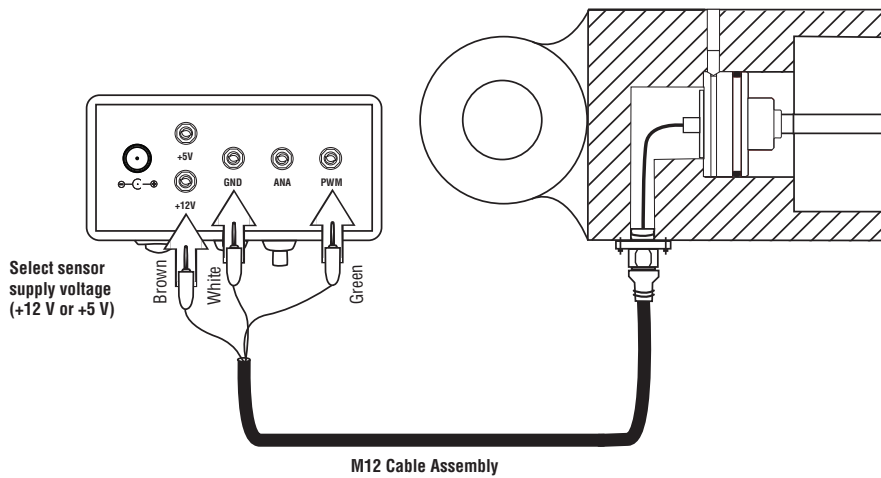

2. Installation (continued)

2.3 Battery Charger

The M-Series tester will also run off AC power supplied by the charger included in the test kit. To run the box of AC power or to charge the battery plug the charger barrel plug into the charger port on the top of the test box and connect the charger to an AC Outlet.

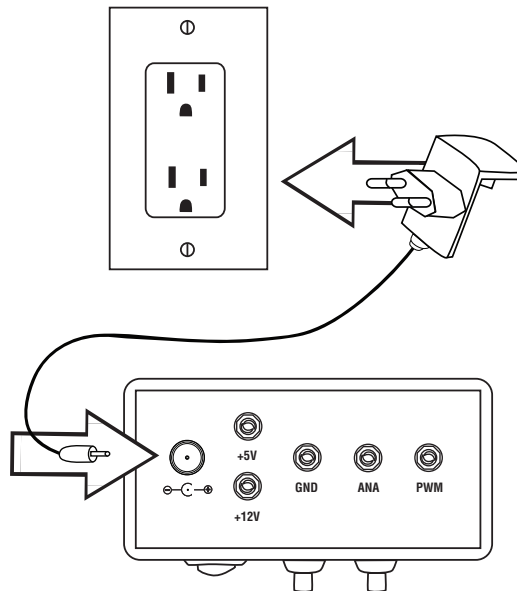

2.4 AC Power Plug Adapter Connection / Replacement

The kits battery charger can be used on both 110 Vdc and 230 Vdc systems. For this reason, additional AC power plug adapters can be purchased (see Accessories).

Use the following steps to change the power plug adapter:

1. Unplug the AC adapter from the wall and from the M-Series Tester. Firmly hold the AC adapter in one hand with the plug facing you.
2. With the other hand, press down on the plug adapter and slide upwards away from you.

To replace the AC power plug adapter:

1. Chose the correct adapter.
2. Slide the adapter plug against the adapter (There are grooves along the channel for the adapter plug). Slide the adapter down until it snaps into place

Note:
There is an arrow on the adapter to denote the way to slide the plug during removal.

2.5 Quick Start Instruction Label

A quick start instruction label is included in the test kit. The label is designed to fit flush on the backside of the M-Series analogue/PWM Tester.

- Remove dust and dirt from the surface of the backside.
- Align and apply the label smoothly on the backside of the tester and apply the label smoothly.

2. Installation (continued)

2.6 Carrier Handle Adjustment

To adjust the position of the carrier handle of the tester, please press and hold both buttons on the side of the handle at the same time. Adjust the position of the handle. After the adjustment release the buttons.

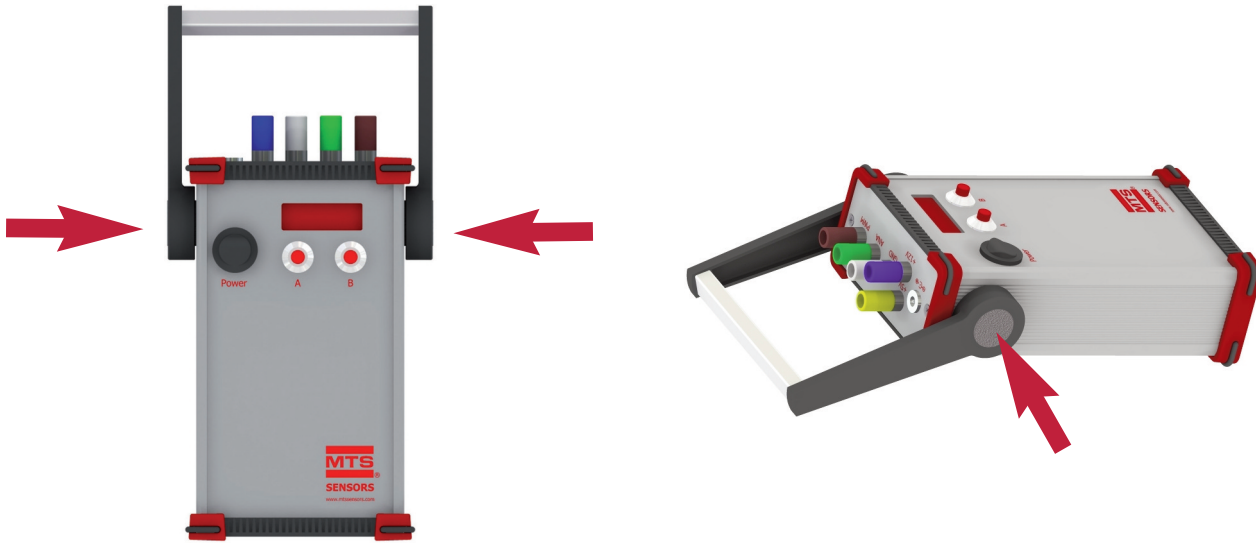

3. Operation

3.1 Start-Up

Perform the following start-up procedure:

1. Turn the tester power switch to the 'ON' position. The test box display will now cycle through the startup display sequence:
 - a) LED test for 1 second
 - b) Software Data test 1 second
 - c) Currently active Mode for 5 seconds

Note:

1. The tester switch is in the 'ON' position when the red LED is lit.
2. If the LED on the power switch is not lit, the device might be in low power mode and the power supply needs to be connected to the charger port on the top of the tester.

The default mode setting is configured for voltage at the factory, but after the initial use, the tester will start up in the last mode the tester was set to.

2. If required, change the mode by pushing the 'A' button. (see 3.2 Mode Selections).
3. Repeat step 2 until the appropriate mode is selected and seen on the display.

3.2 Mode Selections

Mode	Display	Unit
Voltage	Volt	Volts
Current	Curr	Milliamps (mA)
Battery	Batt	Display battery voltage
PWM	Puum	% of Display
TOF	tOF	Millimeters (mm)

3.2.1 Voltage (Volt)

The voltage range will be displayed in Volts for the M-Series sensor with voltage output. It will depend on the sensor model selected.

3. Operations (continued)

3.2.2 Current (Curr)

The current range will be displayed in Milliamps for M-Series sensor with current output. The current range shown will depend on the sensor model selected.

3.2.3 Battery Level (bAtt)

The M-Series tester utilizes a battery to power both the charger and the sensor. The M-Series Tester contains circuitry that continually measures the device battery level to ensure that the necessary voltage is available to power the sensor. If the battery level drops below 9 volts, the tester will not have the power to energize most M-Series sensors. Some M-Series model sensor only require a 5 volt supply and for these transducers test box battery voltage levels lower than 5 volts will interrupt sensor output.

Note:

1. See sensor model specification to determine what supply voltage is needed.
2. The LOBA (Low Battery) status alert will disrupt the output readings of the sensor every 60 seconds for 3 seconds until the power adapter is connected to the tester via the charger port.

Low battery (LOBA)

If 'LOBA' (Low Battery) displays, connect the 12 volt power adapter to the charger port. Whenever the internal battery is allowed to discharge below 1.8 volts, the device will enter low power mode. In the event the device enters low power mode, connect the supply voltage to the charger port and cycle the power. When the battery level drops below 1.8 volts there is not enough voltage to drive the internal circuitry of the M-Series Tester.

3.2.4 Battery Charging

To recharge the battery of the M-Series Tester, connect the supplied AC power plug adapter to the charger port on the top of the device. The LED indicator on the charger will indicate the state of the charging process. The smart charger that is included in the M-Series Tester Kit will give the battery a quick charge first and then apply a constant float charge to maintain battery level.

Warning:

Only use the supplied 12 volts adapter to charge the M-Series Tester. Using an off the shelf AC adapter without smart charging capabilities can result in overcharging the internal Sealed Lead Acid (SLA) batteries. Overcharging the batteries could lead to overheating and damage to the battery cells.

3.2.5 Scaled PWM (Puum)

Configuring the M-Series Tester to PWM mode will allow the output of the scaled PWM sensor to be displayed.

The M-Series Tester will initially show the frequency of the attached scaled PWM sensor output. This will be displayed for 2 seconds before switching the display to the sensor output range.

The scaled PWM sensor output will display the sensor position as a % of the full stroke length. At the zero position the "zero percent"-value for the attached sensor will be displayed. At the full stroke position the "full scale percent"-value for the attached sensor will be displayed.

Example readings for the various sensor types:

PWM Sensor Type	% at Zero Position	% at 1/4 stroke	% at 1/2 stroke	% at 3/4 stroke	% at full stroke
5 % - 95 %	5 %	27,5 %	50 %	72,5 %	95 %
10% - 90 %	10 %	30 %	50 %	70 %	90 %
15 % - 85 %	15 %	32,5 %	50 %	67,5 %	85 %
20 % - 80 %	20 %	35 %	50 %	65 %	80 %
25 % - 75 %	25 %	37,5 %	50 %	62,5 %	75 %

To view the frequency of the scaled PWM sensor:

1. Press the ,A' button once.
2. Frequency will display for 1 second after "puum" for the current mode is displayed.

3. Operations (continued)

3.2.6 PWM Time of Flight (TOF)

Time of Flight mode allows for the M-Series Tester to display the output of a PWM ToF sensor. In a PWM ToF sensor the displacement amount is determined by the time between the creation of the interrogation pulse and the detection of the return pulse in the sensing element. This ToF calculation is dependent on the velocity of the return pulse, sensor length, and the number of recirculations performed by the sensor.

Note:

In order to display millimeters a fixed value has been used for the location of the null with respect to the sensing element. The M-Series Tester is setup for the standard offset in the model MH and MS sensors. For all other models there may be a shift in the output reading due to mechanical differences from the MH and MS models. Please check with the factory for the offset on other M-Series sensor models.

Recirculations:

When the M-Series Tester is in TOF-Mode, the tOF name on the display is followed by a hexadecimal value (0-F) which indicates the number of recirculations expected from the attached sensor. The default hexadecimal value for the mode is 0. The number of recirculations can be changed to accommodate the attached sensor output.

Perform the steps below to reset the number of recirculations:

1. When 'tOF' displays on the screen, press and hold the 'B' button for 2 seconds.
2. The recirculation character (0-F) will begin to blink.
3. When the character is blinking:

Press „B“ button to change the value. Repeat the procedure until the appropriate value displays. Then, press the 'A' button to return to the "tOF" measurement mode.

Display Values	Recirculations
tOF0	0
tOF1	1
tOF2	2
tOF3	3
tOF4	4
tOF5	5
tOF6	6
tOF7	7
tOF8	8
tOF9	9
tOFA	10
tOFb	11
tOFC	12
tOFd	13
tOFE	14
tOFF	15

Note:

Once the 'A' button is pressed the desired recirculation value is saved in the memory.

Note:

1. 'tOF0' denotes that there are no recirculations only the initial interrogation pulse.
2. In the PWM TOF mode if the reported displacement is longer than 4 digits the display will blink and only the most significant digits will be displayed.

3. Operations (continued)

3.3 Verification

Verify the sensor is reading the displacement of the magnet by moving the magnet in the bench test of the attached sensor or by stroking the cylinder. Observe the change in output reading.

Note:

The M-Series Tester is not a calibrated device and should only be used for indication purpose only. The M-Series Tester is designed to be used to verify that the sensor is functional after cylinder assembly and as a field troubleshooting device. For field troubleshooting the tester is designed to isolate the sensor from the rest of the vehicle in order to independently verify sensor functionality.

3.4 Troubleshooting

No Power

1. Confirm the power switch is in 'ON' position
2. M-Series Tester may be in Low Power Mode
3. Plug in AC Power adapter and check the battery level

The sensor readings aren't showing on the display

1. Is the M-Series Tester in the correct mode?
2. Is the M-Series battery level above 9 Vdc?
3. Is the sensor connected to the appropriate terminals?

Error Message '[--]' is seen in PWM or PWM TOF mode

1. Make sure the correct plug is in the PWM port at the top of the M-Series Tester
2. If in TOF mode, make sure the correct number of recirculations is selected
3. Check battery level to ensure the unit is providing a minimum of 9 Vdc to sensor

UNITED STATES
Temposonics, LLC
Americas & APAC Region
3001 Sheldon Drive
Cary, N.C. 27513
Phone: +1 919 677-0100
E-mail: info.us@temposonics.com

GERMANY
Temposonics
GmbH & Co. KG
EMEA Region & India
Auf dem Schüffel 9
58513 Lüdenscheid
Phone: +49 2351 9587-0
E-mail: info.de@temposonics.com

ITALY
Branch Office
Phone: +39 030 988 3819
E-mail: info.it@temposonics.com

FRANCE
Branch Office
Phone: +33 6 14 060 728
E-mail: info.fr@temposonics.com

UK
Branch Office
Phone: +44 79 44 15 03 00
E-mail: info.uk@temposonics.com

SCANDINAVIA
Branch Office
Phone: +46 70 29 91 281
E-mail: info.sca@temposonics.com

CHINA
Branch Office
Phone: +86 21 2415 1000 / 2415 1001
E-mail: info.cn@temposonics.com

JAPAN
Branch Office
Phone: +81 3 6416 1063
E-mail: info.jp@temposonics.com

Document Part Number:
551132 Revision B (EN)

temposonics.com