

Operation Manual

R-Series V PROFINET IO RT & IRT

Magnetostrictive Linear Position Sensors

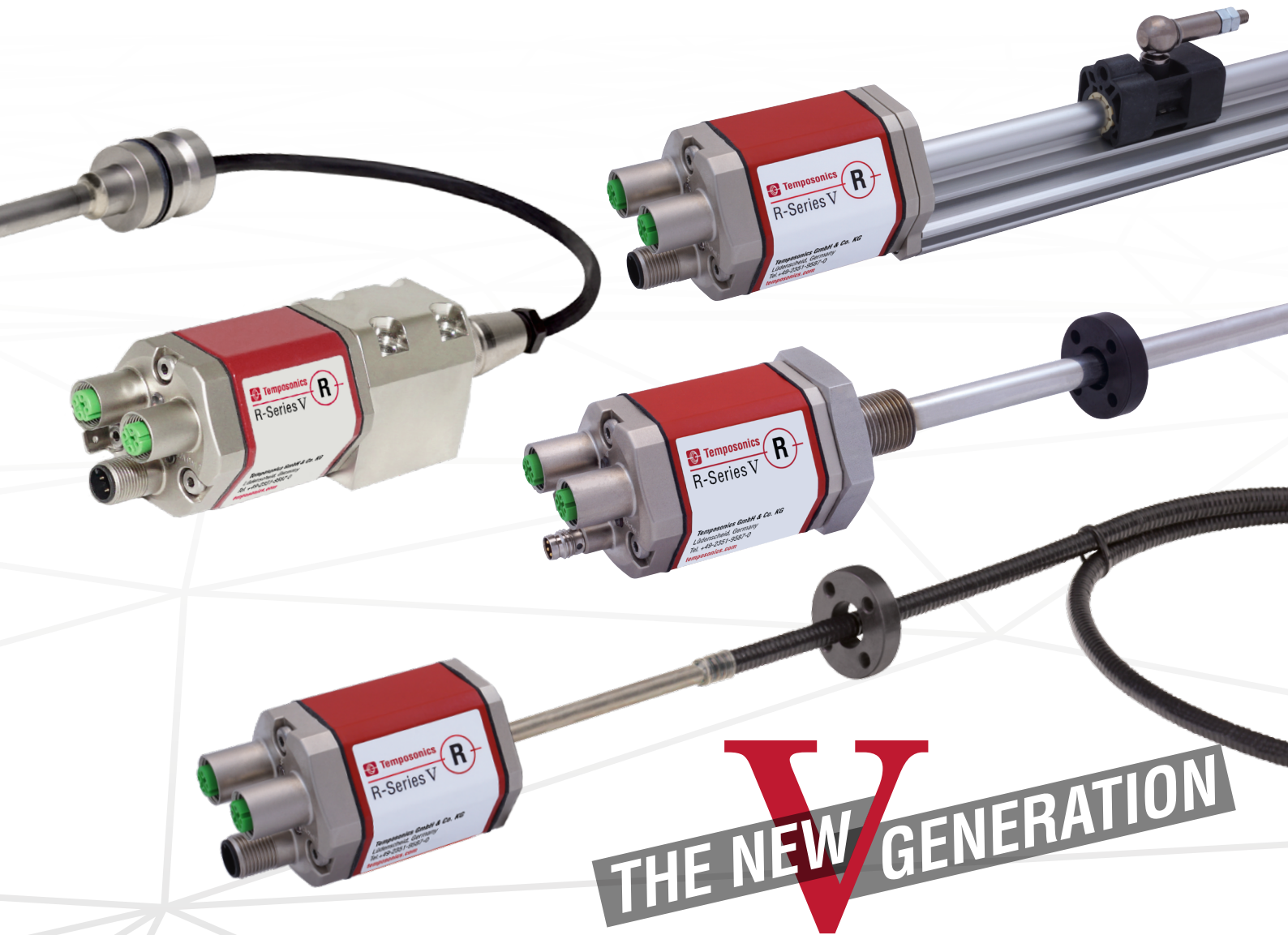

Table of contents

1. Introduction	3
1.1 Purpose and use of this manual	3
1.2 Used symbols and warnings	3
2. Safety instructions	3
2.1 Intended use	3
2.2 Foreseeable misuse	3
2.3 Installation, commissioning and operation	4
2.4 Safety instructions for use in explosion-hazardous areas	4
2.5 Warranty	4
2.6 Return	4
3. Identification	5
3.1 Order code of Temposonics® RP5	5
3.2 Order code of Temposonics® RH5	6
3.3 Order code of Temposonics® RFV	7
3.4 Order code of Temposonics® RDV	8
3.5 Nameplate	9
3.6 Approvals	9
3.7 Scope of delivery	9
4. Product description and commissioning	10
4.1 Functionality and system design	10
4.2 Installation and design of Temposonics® RP5	11
4.3 Installation and design of Temposonics® RH5	12
4.4 Installation and design of Temposonics® RFV	15
4.5 Installation and design of Temposonics® RDV	18
4.6 Magnet installation	23
4.7 Alignment of the magnet with the option "Internal linearization"	27
4.8 Replacement of sensor	29
4.9 Electrical connections	30
4.10 Frequently ordered accessories for RP5 design	32
4.11 Frequently ordered accessories for RH5 design	33
4.12 Frequently ordered accessories for RFV design	34
4.13 Frequently ordered accessories for RDV design	36
4.14 Frequently ordered accessories for PROFINET output	38
5. Operation	40
5.1 Initial start-up	40
5.2 LED status	40
5.3 Supported network functions	41
6. Programming and configuration in the TIA Portal	41
6.1 General Information	41
6.2 Parameter description for linear profile	41
6.3 Parameter description for encoder profile V4.2	47
7. TempoLink® smart assistant with R-Series V PROFINET	53
8. Maintenance and troubleshooting	53
8.1 Error conditions, troubleshooting	53
8.2 Maintenance	53
8.3 Repair	53
8.4 List of spare parts	53
8.5 Transport and storage	53
9. Removal from service/dismantling	53
10. Technical data	54
10.1 Technical data Temposonics® RP5	54
10.2 Technical data Temposonics® RH5	56
10.3 Technical data Temposonics® RFV	58
10.4 Technical data Temposonics® RDV	59
11. Appendix I	61
12. Appendix II	62
13. Glossary	63

1. Introduction

1.1 Purpose and use of this manual

Before starting the operation of Temposonics position sensors, read this documentation thoroughly and follow the safety information. Keep this manual for future reference!

The content of this technical documentation and of its appendix is intended to provide information on mounting, installation and commissioning by qualified automation personnel ¹ or instructed service technicians who are familiar with the project planning and dealing with Temposonics® sensors.

1.2 Used symbols and warnings

Warnings are intended for your personal safety and for avoidance of damage to the described product or connected devices. In this documentation, safety information and warnings to avoid danger that might affect the life and health of operating or service personnel or cause material damage are highlighted by the pictogram defined below.

Symbol	Meaning
NOTICE	This symbol is used to point to situations that may lead to material damage, but not to personal injury.

2. Safety instructions

2.1 Intended use

This product may be used only for the applications defined under item 1 and only in conjunction with the third-party devices and components recommended or approved by Temposonics. As a prerequisite of proper and safe operation the product requires correct transport, storage, mounting and commissioning and must be operated with utmost care.

- The sensor systems of all Temposonics® series are intended exclusively for measurement tasks encountered in industrial, commercial and laboratory applications. The sensors are considered as system accessories and must be connected to suitable evaluation electronics, e.g. a PLC, IPC, indicator or other electronic control unit.

^{1/} The term "qualified technical personnel" characterizes persons who

- are familiar with the safety concepts of automation technology applicable to the particular project and
- are competent in the field of electromagnetic compatibility (EMC) or
- have received adequate training for commissioning and service operations or
- and are familiar with the operation of the device and know the information required for correct operation provided in the product documentation

2.2 Foreseeable misuse

Foreseeable misuse	Consequence
Wrong sensor connection	The sensor will not work properly or can be damaged
Operate the sensor out of the operating temperature range	No signal output – the sensor can be damaged
Power supply is out of the defined range	Signal output is wrong/ no signal output/ the sensor will be damaged
Position measurement is influenced by an external magnetic field	Signal output is wrong
Cables are damaged	Short circuit – the sensor can be damaged/sensor does not respond
Spacers are missing/ installed in a wrong order	Error in position measurement
Wrong connection of ground/shield	Signal output is disturbed – the electronics can be damaged
Use of a magnet that is not specified by Temposonics	Error in position measurement

Do not alter the sensor afterwards.
→ The sensor might be damaged.

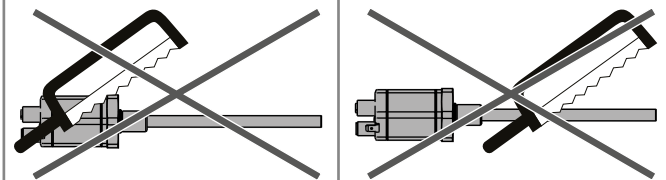

Do not step on the sensor.
→ The sensor might be damaged.

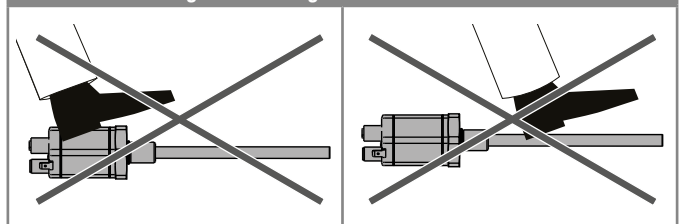

2.3 Installation, commissioning and operation

The position sensors must be used only in technically safe conditions. To maintain this condition and to ensure safe operation, installation, connection and service, work may be performed only by qualified technical personnel.

If danger of injury to persons or of damage to operating equipment is caused by sensor failure or malfunction, additional safety measures such as plausibility checks, limit switches, EMERGENCY STOP systems, protective devices etc. are required. In the event of trouble, shut down the sensor and protect it against accidental operation.

Safety instructions for commissioning

To maintain the sensor's operability, it is mandatory to follow the instructions given below.

1. Protect the sensor against mechanical damage during installation and operation.
2. Do not open or dismantle the sensor.
3. Connect the sensor very carefully and pay attention to the polarity of connections and power supply.
4. Use only approved power supplies.
5. Ensure the sensor is operating within the defined limits for supply voltage, environmental conditions, etc.
6. Check the function of the sensor regularly and provide documentation of the checks.
7. Before applying power, ensure that nobody's safety is jeopardized by starting machines.

2.4 Safety instructions for use in explosion-hazardous areas

The sensor is not suitable for operation in explosion-hazardous areas.

2.5 Warranty

Temposonics grants a warranty period for the position sensors and supplied accessories relating to material defects and faults that occur despite correct use in accordance with the intended application². The Temposonics obligation is limited to repair or replacement of any defective part of the unit. No warranty can be provided for defects that are due to improper use or above average stress of the product, as well as for wear parts. Under no circumstances will Temposonics accept liability in the event of offense against the warranty rules, no matter if these have been assured or expected, even in case of fault or negligence of the company.

Temposonics explicitly excludes any further warranties. Neither the company's representatives, agents, dealers nor employees are authorized to increase or change the scope of warranty.

2.6 Return

For diagnostic purposes, the sensor can be returned to Temposonics or a repair facility explicitly authorized by Temposonics. Any shipment cost is the responsibility of the sender². For a corresponding form, see chapter "11. Appendix I" on page 61.

NOTICE

When returning sensors, place protective caps on male and female connectors of the sensor. For pigtail cables, place the cable ends in a static shielding bag for electrostatic discharge (ESD) protection. Fill the outer packaging around the sensor completely to prevent damage during transport.

2/ See also applicable Temposonics terms of sales and delivery on:
www.temposonics.com

3. Identification

3.1 Order code of Temposonics® RP5

1	2	3	4	5	6	7	8	9	10	11	12	13	14	15	16	17	18	19	20	
R	P	5										D	5		1	U	4			
a			b	c	d						e		f			g	h			

a	Sensor model		
R	P	5	Profile

b	Design
G	Magnet slider backlash free (part no. 253 421), suitable for internal linearization
L	Block magnet L (part no. 403 448)
M	U-magnet OD33 (part no. 251 416-2), suitable for internal linearization
N	Magnet slider longer ball-jointed arm (part no. 252 183), suitable for internal linearization
O	No position magnet
S	Magnet slider joint at top (part no. 252 182), suitable for internal linearization
V	Magnet slider joint at front (part no. 252 184), suitable for internal linearization

c	Mechanical options
A	Standard
V	Fluorelastomer seals for the sensor electronics housing

d	Stroke length				
X	X	X	X	M	0025...6350 mm
Standard stroke length (mm)		Ordering steps			
25... 500 mm		25 mm			
500...2500 mm		50 mm			
2500...5000 mm		100 mm			
5000...6350 mm		250 mm			
X	X	X	X	U	001.0...250.0 in.
Standard stroke length (in.)		Ordering steps			
1... 20 in.		1.0 in.			
20...100 in.		2.0 in.			
100...200 in.		4.0 in.			
200...250 in.		10.0 in.			

Non-standard stroke lengths are available; must be encoded in 5 mm/0.1 in. increments.

e	Number of magnets	
X	X	01...30 position(s) (1...30 magnet(s))

f	Connection type		
D	5	8	2 × M12 female connectors (D-coded), 1 × M12 male connector (A-coded)
D	5	6	2 × M12 female connectors (D-coded), 1 × M8 male connector

g	System
1	Standard

h	Output			
U	4	0	2	PROFINET RT & IRT, position and velocity, linear profile (1...30 magnet(s))
U	4	0	1	PROFINET RT & IRT, position and velocity, encoder profile (1 magnet)
U	4	1	2	PROFINET RT & IRT, position and velocity, linear profile, internal linearization (1...30 magnet(s))
U	4	1	1	PROFINET RT & IRT, position and velocity, encoder profile, internal linearization (1 magnet)

NOTICE

- Select the linear profile (U402 or U412) in **h** "Output" for multi-position measurement.
- For the RP5, the magnet selected in **b** "Design" is included in the scope of delivery. Specify the number of magnets for your application. For multi-position measurements with more than 1 magnet, order the other magnets separately.
- The number of magnets is limited by the stroke length. The minimum allowed distance between magnets (i.e. front face of one to the front face of the next one) is 75 mm (3 in.).
- Use magnets of the same type for multi-position measurement.
- If the option for internal linearization (U411, U412) in **h** "Output" is chosen, select a suitable magnet.

3.2 Order code of Temposonics® RH5

1	2	3	4	5	6	7	8	9	10	11	12	13	14	15	16	17	18	19	20
R	H	5										D	5		1	U	4		
a			b	c	d						e	f			g	h			

a	Sensor model		
R	H	5	Rod

b	Design
B	Base unit (only for replacement)
J	Threaded flange M22×1.5-6g (rod Ø 12.7 mm), stroke length: 25...5900 mm (1...232 in.)
M	Threaded flange M18×1.5-6g (standard)
S	Threaded flange ¾"-16 UNF-3A (standard)
T	Threaded flange ¾"-16 UNF-3A (with raised-face)

c	Mechanical options
A	Standard
B	Bushing on rod end (only for design »M«, »S« & »T«)
M	Thread M4 at rod end (only for design »M«, »S« & »T«)
V	Fluorelastomer seals for the sensor electronics housing

d	Stroke length				
X	X	X	X	M	0025...7620 mm
Standard stroke length (mm)		Ordering steps			
25... 500 mm		5 mm			
500... 750 mm		10 mm			
750...1000 mm		25 mm			
1000...2500 mm		50 mm			
2500...5000 mm		100 mm			
5000...7620 mm		250 mm			
X	X	X	X	U	001.0...300.0 in.
Standard stroke length (in.)		Ordering steps			
1... 20 in.		0.2 in.			
20... 30 in.		0.4 in.			
30... 40 in.		1.0 in.			
40...100 in.		2.0 in.			
100...200 in.		4.0 in.			
200...300 in.		10.0 in.			
Non-standard stroke lengths are available; must be encoded in 5 mm/0.1 in. increments.					

e	Number of magnets	
X	X	01...30 position(s) (1...30 magnet(s))

f	Connection type		
D	5	8	2×M12 female connectors (D-coded), 1×M12 male connector (A-coded)
D	5	6	2×M12 female connectors (D-coded), 1×M8 male connector

g	System
1	Standard

h	Output			
U	4	0	2	PROFINET RT & IRT, position and velocity, linear profile (1...30 magnet(s))
U	4	0	1	PROFINET RT & IRT, position and velocity, encoder profile (1 magnet)
U	4	1	2	PROFINET RT & IRT, position and velocity, linear profile, internal linearization (1...30 magnet(s))
U	4	1	1	PROFINET RT & IRT, position and velocity, encoder profile, internal linearization (1 magnet)

NOTICE

- Select the linear profile (U402 or U412) in **h** "Output" for multi-position measurement.
- Specify the number of magnets for your application and order the magnets separately.
- The number of magnets is limited by the stroke length. The minimum allowed distance between magnets (i.e. front face of one to the front face of the next one) is 75 mm (3 in.).
- Use magnets of the same type for multi-position measurement.
- If the option for internal linearization (U411, U412) in **h** "Output" is chosen, select a suitable magnet.

3.3 Order code of Temposonics® RFV

1	2	3	4	5	6	7	8	9	10	11	12	13	14	15	16	17	18	19	20
R	F	V										D	5		1	U	4	0	
a			b	d						e		f			g	h			

a	Sensor model
R F V	Flexible rod

b	Design
B	Base unit
M	Threaded flange M18×1.5-6g (standard)
S	Threaded flange ¾"-16 UNF-3A (standard)

Section **c** is intentionally omitted.

d	Stroke length
X X X X X M	00150...20000 mm
Stroke length (mm)	Ordering steps
150... 1000 mm	50 mm
1000... 5000 mm	100 mm
5000... 10000 mm	250 mm
10000... 15000 mm	500 mm
15000... 20000 mm	1000 mm
X X X X X U	0006.0...0787.0 in.
Stroke length (in.)	Ordering steps
6... 40 in.	2 in.
40... 197 in.	4 in.
197... 394 in.	10 in.
394... 591 in.	20 in.
591... 787 in.	40 in.

Non standard stroke lengths are available;
must be encoded in 5 mm/0.1 in. increments

e	Number of magnets
X X	01...30 position(s) (1...30 magnet(s))

f	Connection type
D 5 8	2 × M12 female connectors (D-coded), 1 × M12 male connector (A-coded)
D 5 6	2 × M12 female connectors (D-coded), 1 × M8 male connector

g	System
1	Standard

h	Output
U 4 0 2	PROFINET RT & IRT, position and velocity, linear profile (1...30 magnet(s))
U 4 0 1	PROFINET RT & IRT, position and velocity, encoder profile (1 magnet)

NOTICE

- Select the linear profile (U402) in **h** "Output" for multi-position measurement.
- Specify number of magnets for your application and order the magnets separately.
- The number of magnets is limited by the stroke length. The minimum allowed distance between magnets (i.e. front face of one to the front face of the next one) is 75 mm (3 in.).
- Use magnets of the same type for multi-position measurement.

3.4 Order code of Temposonics® RDV

1	2	3	4	5	6	7	8	9	10	11	12	13	14	15	16	17	18	19	20
R	D	V										D	5		1	U	4		
a			b	c	d						e	f			g	h			

a	Design
R D V	Detached sensor electronics "Classic"

b	Design
C	Threaded flange M18×1.5-6g (A/F 46)
D	Threaded flange ¾"-16 UNF-3A (A/F 46)
M	Threaded flange M18×1.5-6g (A/F 24)
S	Pressure fit flange Ø 26.9 mm f6
T	Threaded flange ¾"-16 UNF-3A (A/F 23)

c	Mechanical options
For side cable entry	
A	PUR cable with M16 connector, 250 mm length
B	PUR cable with M16 connector, 400 mm length
C	PUR cable with M16 connector, 600 mm length
For bottom cable entry	
2	Single wires with flat connector, 65 mm length
4	Single wires with flat connector, 170 mm length
5	Single wires with flat connector, 230 mm length
6	Single wires with flat connector, 350 mm length

d	Stroke length
X X X X M	Flange »S«: 0025...2540 mm Flange »C«, »D«, »M«, »T«: 0025...5080 mm
Stroke length (mm)	Ordering steps
25... 500 mm	5 mm
500... 750 mm	10 mm
750...1000 mm	25 mm
1000...2500 mm	50 mm
2500...5080 mm	100 mm
X X X X U	Flange »S«: 001.0...100.0 in. Flange »C«, »D«, »M«, »T«: 001.0...200.0 in.
Stroke length (in.)	Ordering steps
1... 20 in.	0.2 in.
20... 30 in.	0.4 in.
30... 40 in.	1.0 in.
40...100 in.	2.0 in.
100...200 in.	4.0 in.
Non standard stroke lengths are available; must be encoded in 5 mm/0.1 in. increments	

e	Number of magnets
X X	01...30 position(s) (1...30 magnet(s))

f	Connection type
D 5 8	2×M12 female connectors (D-coded), 1×M12 male connector (A-coded)
D 5 6	2×M12 female connectors (D-coded), 1×M8 male connector

g	System
1	Standard

h	Output
U 4 0 2	PROFINET RT & IRT, position and velocity, linear profile (1...30 magnet(s))
U 4 0 1	PROFINET RT & IRT, position and velocity, encoder profile (1 magnet)
U 4 1 2	PROFINET RT & IRT, position and velocity, linear profile, internal linearization (1...30 magnet(s))
U 4 1 1	PROFINET RT & IRT, position and velocity, encoder profile, internal linearization (1 magnet)

NOTICE

- Select the linear profile (U402) in **h** "Output" for multi-position measurement.
- Specify number of magnets for your application and order the magnets separately.
- The number of magnets is limited by the stroke length. The minimum allowed distance between magnets (i.e. front face of one to the front face of the next one) is 75 mm (3 in.).
- Use magnets of the same type for multi-position measurement.
- If the option for internal linearization (U411, U412) in **h** "Output" is chosen, select a suitable magnet.

3.5 Nameplate



Fig. 1: Example of nameplate of R-Series V RP5 sensor with PROFINET output

3.6 Approvals

- PNO certified
- CE declaration
- UKCA declaration
- EAC declaration
- UL certified

3.7 Scope of delivery

RP5 (profile sensor):

- Sensor
- Position magnet (not valid for RP5 with design »0«)
- 2 mounting clamps up to 1250 mm (50 in.) stroke length +
1 mounting clamp for each 500 mm (20 in.) additional stroke length

RH5 (rod sensor):

- RH5-B: Base unit (without flange & rod assembly),
3 × socket screws M4×59
- RH5-J/M/S/T: Sensor, O-ring

RFV (flexible rod sensor):

- RFV-B: Sensor (without flange & rod assembly),
3 × socket screws M4×59
- RFV-M/-S: Sensor, O-ring

RDV (detached sensor electronics):

- RDV-C/-D/-M/-T: Sensor, O-ring
- RDV-S: Sensor, O-ring, back-up ring

4. Product description and commissioning

4.1 Functionality and system design

Product designation

- Position sensor Temposonics® R-Series V

Sensor model

- Temposonics® R-Series V RP5 (profile sensor)
- Temposonics® R-Series V RH5 (rod sensor)
- Temposonics® R-Series V RFV (flexible rod sensor)
- Temposonics® R-Series V RDV (detached sensor electronics)

Stroke length

- Temposonics® R-Series V RP5: 25...6350 mm (1...250 in.)
- Temposonics® R-Series V RH5: 25...7620 mm (1...300 in.)
- Temposonics® R-Series V RFV: 150...20,000 mm (6...787 in.)
- Temposonics® R-Series V RDV: 25...5080 mm (1...200 in.)

Output signal

- PROFINET RT & IRT

Application

The Temposonics® position sensors are used for measurement and conversion of the length (position) variable in the fields of automated systems and mechanical engineering.

Principle of operation and system construction

The absolute, linear position sensors provided by Temposonics rely on the company's proprietary Temposonics® magnetostrictive technology, which can determine position with a high level of precision and robustness. Each Temposonics® position sensor consists of a ferromagnetic waveguide, a position magnet, a strain pulse converter and supporting electronics. The magnet, connected to the object in motion in the application, generates a magnetic field at its location on the waveguide. A short current pulse is applied to the waveguide. This creates a momentary radial magnetic field and torsional strain on the waveguide. The momentary interaction of the magnetic fields releases a torsional strain pulse that propagates the length of the waveguide. When the ultrasonic wave reaches the end of the waveguide it is converted into an electrical signal. Since the speed of the ultrasonic wave in the waveguide is precisely known, the time required to receive the return signal can be converted into a linear position measurement with both high accuracy and repeatability.

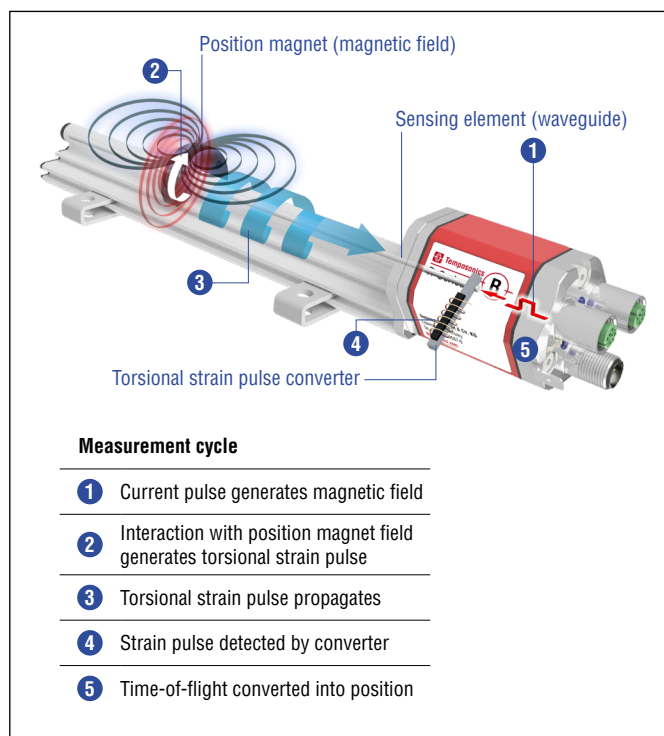

Fig. 2: Time-based magnetostrictive position sensing principle

Modular mechanical and electronic construction

- The sensor rod or profile protects the inner sensor element.
- The sensor electronics housing, a rugged aluminum construction, contains the complete electronic interface with active signal conditioning.
- The external position magnet is a permanent magnet. Mounted on the mobile machine part, it travels along the sensor rod or profile and triggers the measurement through the sensor rod wall.
- The sensor can be connected directly to a control system. Its electronics generates a strictly position-proportional signal output between start and end position.

4.2 Installation and design of Temposonics® RP5

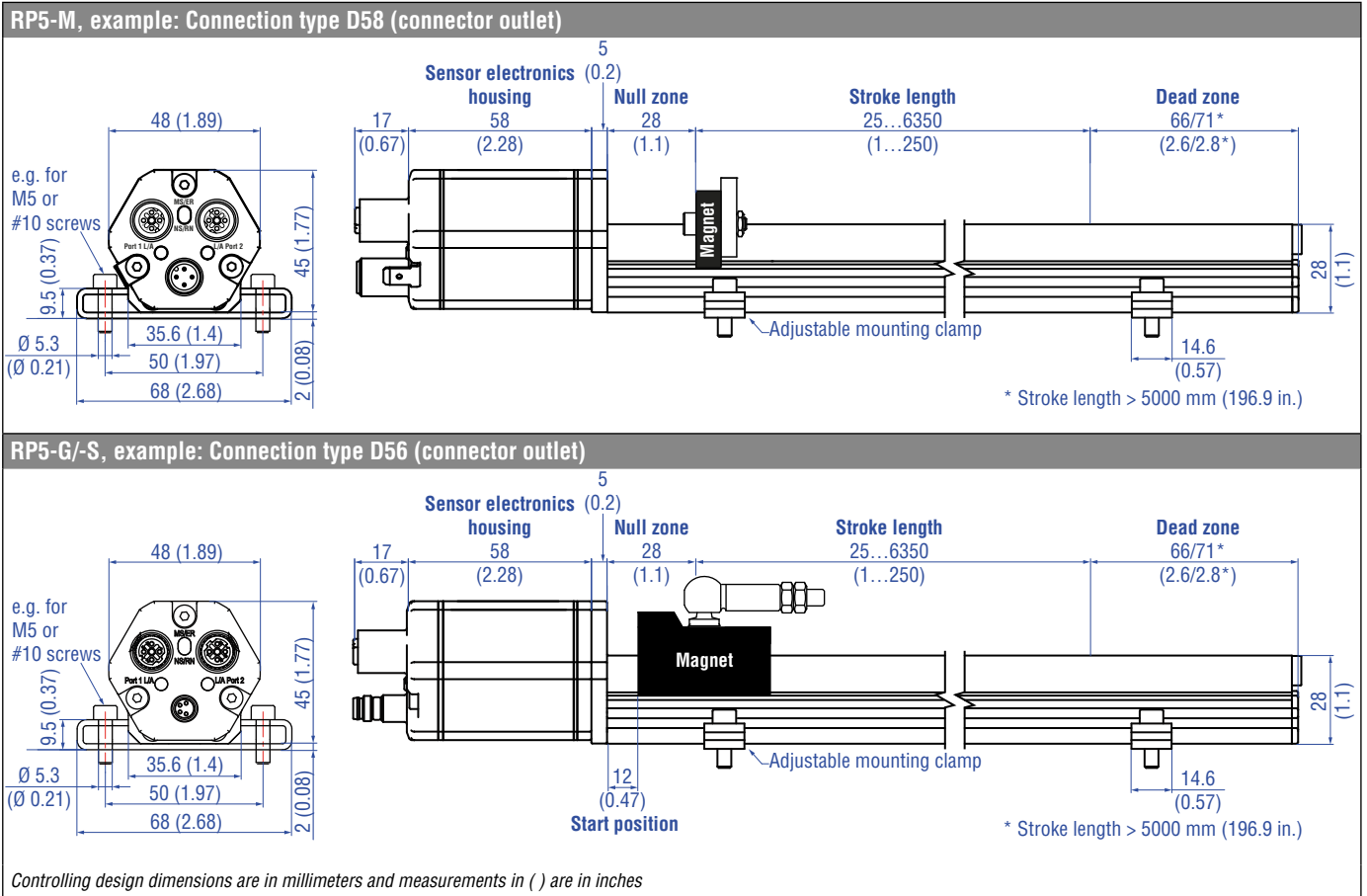

Fig. 3: Temposonics® RP5 with U-magnet/magnet slider

Installation of RP5

The position sensor can be installed in any position. Normally, the sensor is firmly installed and the position magnet is fastened to the mobile machine part. Thus it can travel along the sensor profile. The sensor is fitted on a flat machine surface using the mounting clamps (Fig. 4). A length-dependent number of these clamps are delivered with the sensor and must be distributed over the profile at regular distances. For fastening use M5×20 screws to DIN 6912 that should be tightened with a fastening torque of 5 Nm.

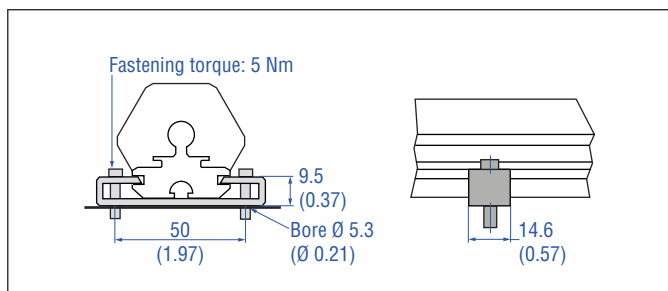

Fig. 4: Mounting clamps (part no. 400 802) with cylinder screw M5×20

Alternative:

If only limited space is available, the profile sensor can be mounted also via the T-rail in the profile bottom using a T-slot nut M5 (part no. 401 602) or a sliding block (Fig. 5).

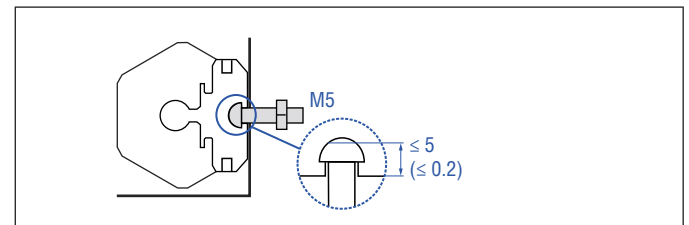

Fig. 5: T-slot nut M5 (part no. 401 602)

NOTICE

Take care to mount the sensor in an axially parallel position to avoid damage to magnet and sensor.

Controlling design dimensions are in millimeters and measurements in () are in inches

4.3 Installation and design of Temposonics® RH5

RH5-M/-S-A/-V – RH5 with threaded flange M18×1.5-6g or ¾"-16 UNF-3A, example: Connection type D58 (connector outlet)

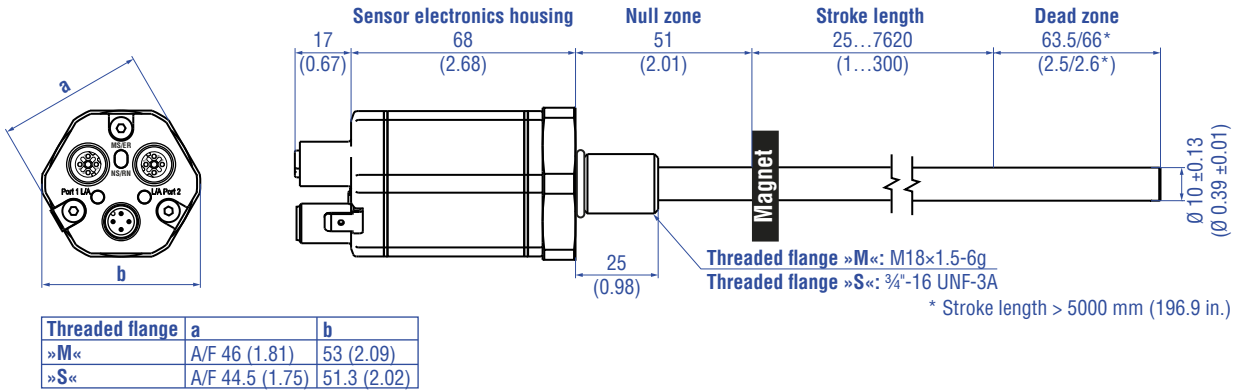

RH5-T-A/-V – RH5 with threaded flange ¾"-16 UNF-3A with raised-face, example: Connection type D56 (connector outlet)

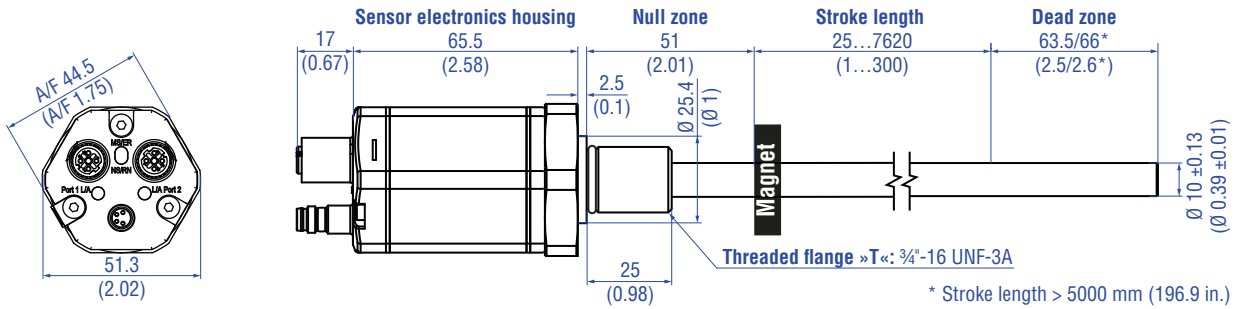

Mechanical option »B«: Bushing on rod end for threaded flange M18×1.5-6g or ¾"-16 UNF-3A

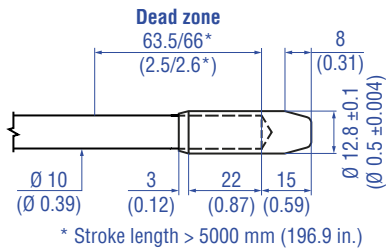

Mechanical option »M«: Thread M4 at rod end for threaded flange M18×1.5-6g or ¾"-16 UNF-3A

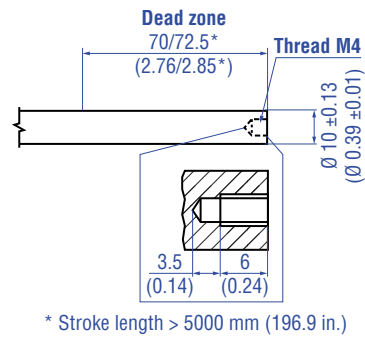

Controlling design dimensions are in millimeters and measurements in () are in inches

Fig. 6: Temposonics® RH5 with ring magnet, part 1

RH5-J-A/-V – RH5 with threaded flange M22×1.5-6g and Ø 12.7 mm rod, example: Connection type D56 (connector outlet)

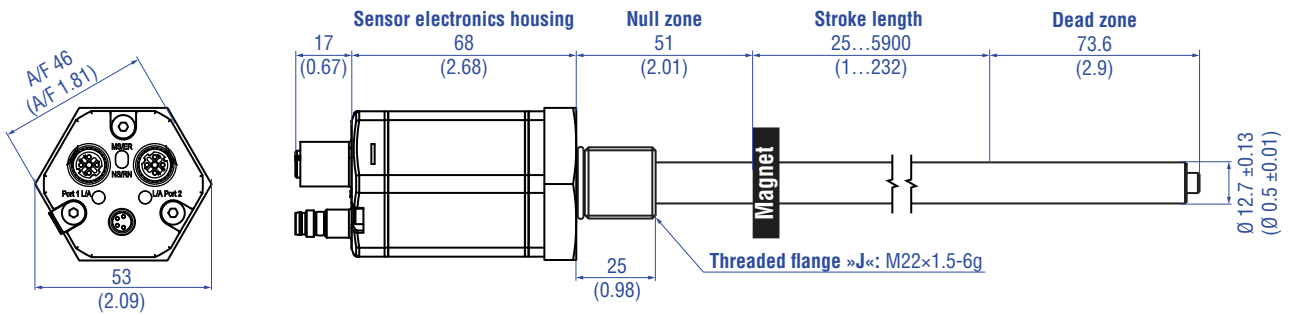

RH5-B-A/-V – RH5 base unit (only for replacement), example: Connection type D58 (connector outlet)

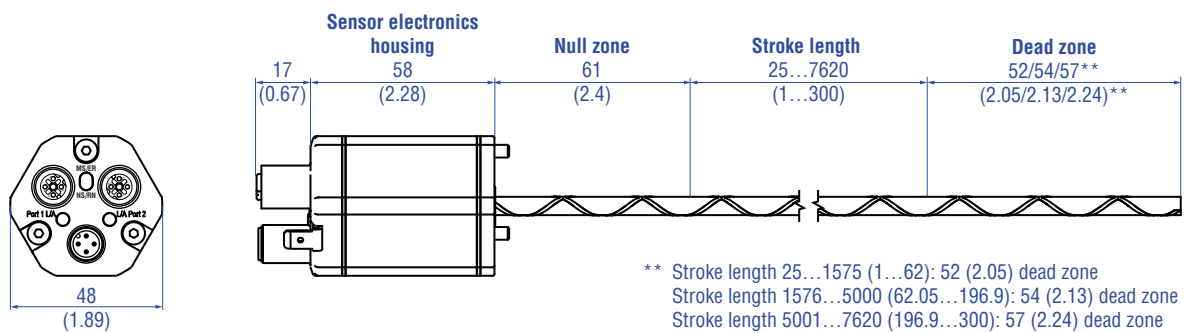

Controlling design dimensions are in millimeters and measurements in () are in inches

Fig. 7: Temposonics® RH5 with ring magnet, part 2

Installation of RH5 with threaded flange

Fix the sensor rod via threaded flange M18×1.5-6g, M22×1.5-6g or 3/4"-16 UNF-3A.

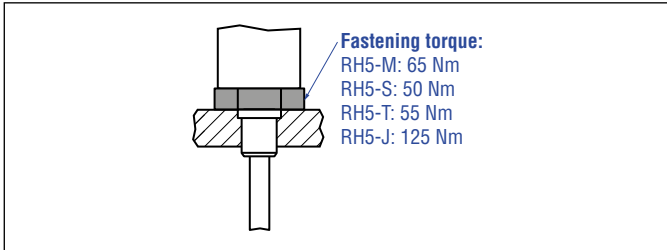

Fig. 8: Mounting example of threaded flange

Installation in a fluid cylinder

The rod-style version has been developed for direct stroke measurement in a fluid cylinder. Mount the sensor via threaded flange or a hex nut.

- Mounted on the face of the piston, the position magnet travels over the rod without touching it and indicates the exact position through the rod wall – independent of the hydraulic fluid.
- The pressure resistant sensor rod is installed into a bore in the piston rod.
- The base unit is mounted by means of three screws. It is the only part that needs to be replaced if servicing is required, i.e. the hydraulic circuit remains closed. For more information see chapter “4.8 Replacement of sensor” on page 29.

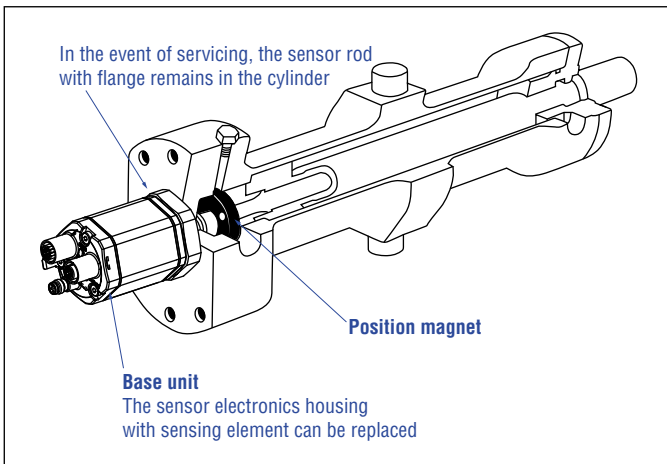

Fig. 9: Sensor in cylinder

Hydraulics sealing

There are two ways to seal the flange contact surface (Fig. 10):

1. A sealing by using an O-ring (e.g. 22.4 × 2.65 mm (0.88 × 0.1 in.), 25.07 × 2.62 mm (0.99 × 0.1 in.)) in a cylinder end cap groove.
2. A sealing by using an O-ring in the flange undercut.

For threaded flange (3/4"-16 UNF-3A):

O-ring 16.4 × 2.2 mm (0.65 × 0.09 in.) (part no. 560 315)

For threaded flange (M18×1.5-6g):

O-ring 15.3 × 2.2 mm (0.60 × 0.09 in.) (part no. 401 133)

For threaded flange (M22×1.5-6g):

O-ring 19.2 × 2.2 mm (0.76 × 0.09 in.) (part no. 561 337)

In the case of threaded flange M18×1.5-6g or M22×1.5-6g, provide a screw hole based on ISO 6149-1 (Fig. 11). See ISO 6149-1 for further information.

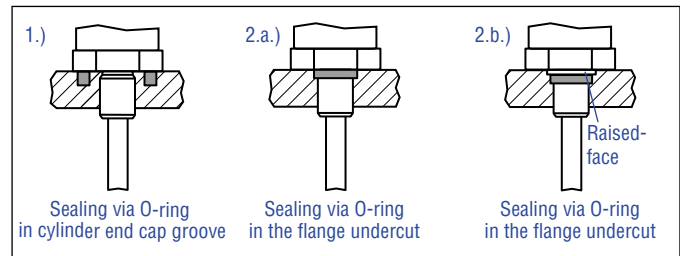

Fig. 10: Possibilities of sealing for threaded flange with flat face 1. + 2.a. (RH5-J/-M/-S) and with raised-face 2.b. (RH5-T)

- Note the fastening torque:
RH5-M: 65 Nm
RH5-S: 50 Nm
RH5-T: 55 Nm
RH5-J: 125 Nm
- Seat the flange contact surface completely on the cylinder mounting surface.
- The cylinder manufacturer determines the pressure-resistant gasket (copper gasket, O-ring, etc.).
- The position magnet should not grind on the sensor rod.
- The piston rod drilling (RH5-M/-S/-T-A/-M/-V with rod Ø 10 mm: ≥ Ø 13 mm (≥ Ø 0.51 in.); RH5-M/-S/-T-B with rod Ø 10 mm: ≥ Ø 16 mm (≥ Ø 0.63 in.); RH5-J-A/-V with rod Ø 12.7 mm: ≥ Ø 16 mm (≥ Ø 0.63 in.)) depends on the pressure and piston speed.
- Adhere to the information relating to operating pressure.
- Protect the sensor rod against wear.

Notice for metric threaded flanges									
Thread (d ₁ ×P)	d ₂	d ₃	d ₄	d ₅ +0.1 0	L ₁ +0.4 0	L ₂	L ₃	L ₄	Z° ±1°
RH5-M-A/-M/-V									
M18×1.5-6g	55	≥ 13	24.5	19.8	2.4	28.5	2	26	15°
RH5-M-B									
M18×1.5-6g	55	≥ 16	24.5	19.8	2.4	28.5	2	26	15°
RH5-J-A/-V									
M22×1.5-6g	55	≥ 16	27.5	23.8	2.4	28.5	2	26	15°

Fig. 11: Notice for metric threaded flange M18×1.5-6g/M22×1.5-6g based on DIN ISO 6149-1

4.4 Installation and design of Temposonics® RFV

RFV-B – RFV base unit, example: Connection type D56 (connector outlet)

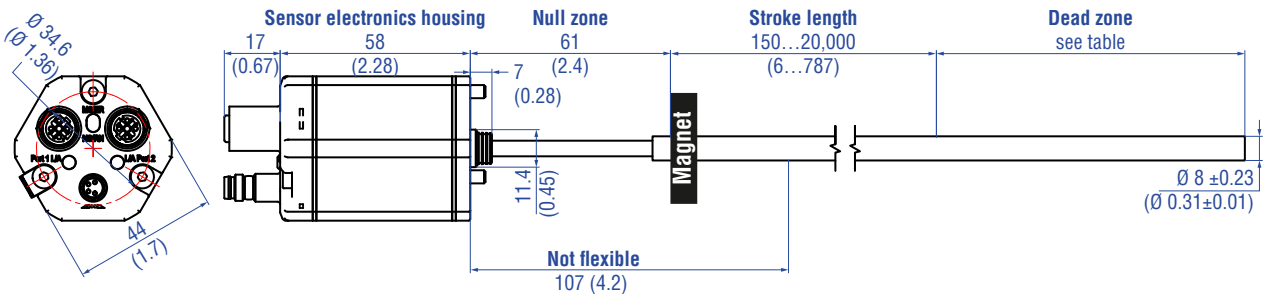

Stroke length	Tolerance of total length	Dead zone
Up to 7620 mm (300.00 in.)	+8 mm (0.31 in.)/-5 mm (0.20 in.)	94 mm (3.70 in.)
Up to 10,000 mm (393.70 in.)	+15 mm (0.59 in.)/-15 mm (0.59 in.)	100 mm (3.94 in.)
Up to 15,000 mm (590.55 in.)	+15 mm (0.59 in.)/-30 mm (1.18 in.)	120 mm (4.72 in.)
Up to 20,000 mm (787.00 in.)	+15 mm (0.59 in.)/-45 mm (1.77 in.)	140 mm (5.51 in.)

Note: Tolerance of total length has no influence on the stroke length.

RFV-M/-S – RFV with threaded flange M18×1.5-6g or ¾"-16 UNF-3A, example: Connection type D58 (connector outlet)

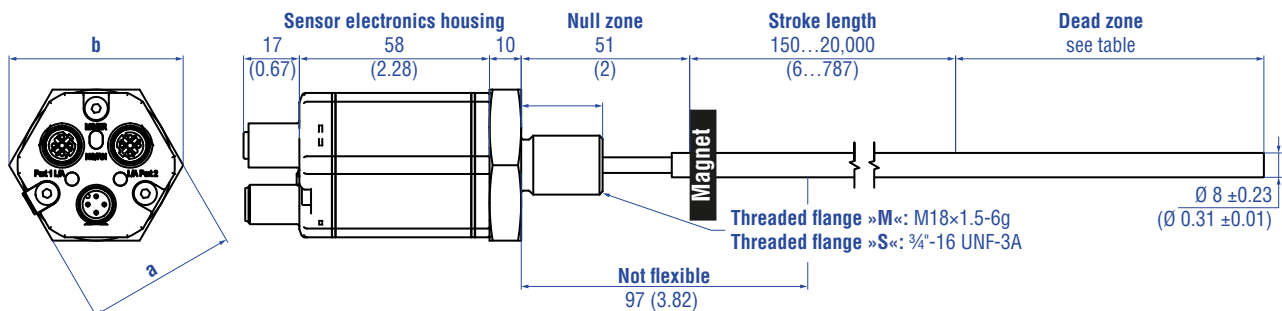

Threaded flange	a	b
»M«	A/F 46 (1.81)	53 (2.09)
»S«	A/F 44.5 (1.75)	51.3 (2.02)

Stroke length	Tolerance of total length	Dead zone
Up to 7620 mm (300.00 in.)	+8 mm (0.31 in.)/-5 mm (0.20 in.)	94 mm (3.70 in.)
Up to 10,000 mm (393.70 in.)	+15 mm (0.59 in.)/-15 mm (0.59 in.)	100 mm (3.94 in.)
Up to 15,000 mm (590.55 in.)	+15 mm (0.59 in.)/-30 mm (1.18 in.)	120 mm (4.72 in.)
Up to 20,000 mm (787.00 in.)	+15 mm (0.59 in.)/-45 mm (1.77 in.)	140 mm (5.51 in.)

Note: Tolerance of total length has no influence on the stroke length.

Controlling design dimensions are in millimeters and measurements in () are in inches

Fig. 12: Temposonics® RFV with ring magnet

Installation of RFV

Note the following information when mounting and handling an RFV sensor:

1. Always insert the flexible sensor rod in a support tube (e.g. pressure rod HD/HL/HP or HFP profile). The support tube has to be made of non-magnetic material and has to have an inside diameter of minimum 9.4 mm (0.37 in.) (Fig. 13). The support tube can be straight or bent.
2. Do never bend beyond the minimum bending radius of 250 mm (9.84 in.).
3. Note the minimum distance to a spatial limitation of 300 mm (11.81 in.), when mounting/dismounting the sensor. The recommended distance is 500 mm (20 in.) (Fig. 14).
4. Note the non-flexible area of the sensor rod from the flange of 107 mm (4.21 in.) (for RFV-B) respectively 97 mm (3.82 in.) (for RFV-M/-S).

NOTICE

Smaller radiuses < 250 mm (9.84 in.) cause damage to the flexible sensor rod.

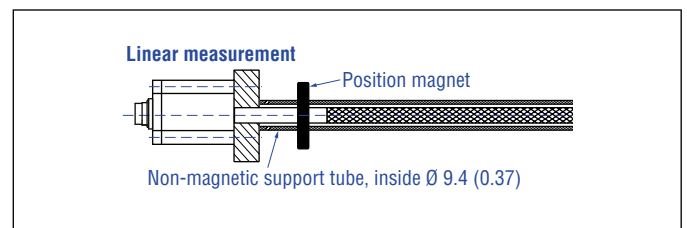

Fig. 13: Sensor with support tube

Controlling design dimensions are in millimeters and measurements in () are in inches

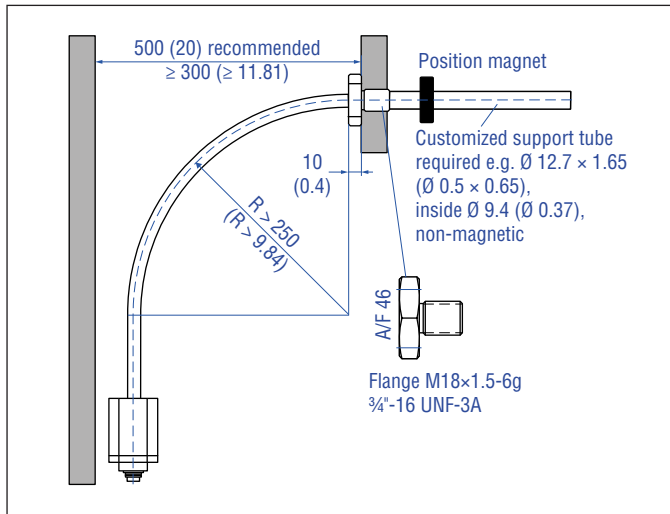

Fig. 14: Clearances for installation and handling

Mounting the RFV

1. RFV-B

- Insert the flexible sensor rod in a support tube.
- Mount the sensor electronics housing by means of 3 non-magnetic socket head screws M4x59. Fastening torque: 1.4 Nm (Fig. 15). Secure the screws, e.g. using Loctite 243, before re-installing.

Recommendation: Seal the sensor via flange.

2. RFV-B with pressure rod HD/HL/HP or HFP profile (see "Frequently ordered accessories")

- Advantage: The flexible sensor rod is inserted in a support tube.
- Mount the sensor electronics housing by means of 3 non-magnetic socket head screws M4x59. Fastening torque: 1.4 Nm (Fig. 15). Secure the screws, e.g. using Loctite 243, before re-installing.
- Installation details: see below

3. RFV-M/-S

- Insert the flexible sensor rod in a support tube.
- Mount the sensor via flange.
- Installation details: see below

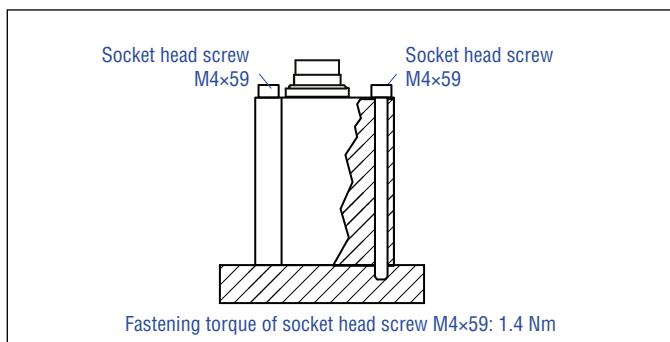

Fig. 15: Mounting with socket head screws M4x59

NOTICE

To fulfill the requirements of EMC standards for emission and immunity the following points are necessary:

- The sensor electronics housing has to be connected to machine ground (Fig. 47).
- Embed the flexible sensor element in an appropriately shielded environment, e.g. in a pressure rod HD/HL/HP.

Installation of RFV with threaded flange »M« or »S«

Fix the sensor rod via threaded flange M18x1.5-6g or 3/4"-16 UNF-3A.

Note the fastening torque of

RFV-M: 65 Nm

RFV-S: 50 Nm

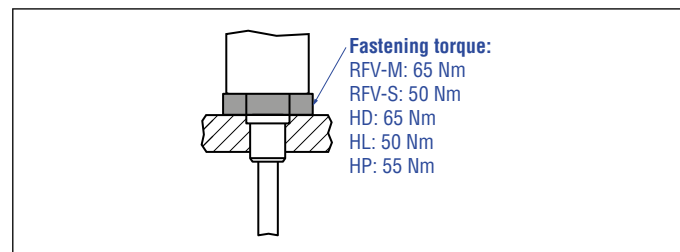

Fig. 16: Mounting example of threaded flange

Installation of RFV sensor with pressure rod HD/HL/HP in a fluid cylinder

The rod-style version has been developed for direct stroke measurement in a fluid cylinder. Mount the sensor via threaded flange or a hex nut.

- Mounted on the face of the piston, the position magnet travels over the rod without touching it and indicates the exact position through the rod wall – independent of the hydraulic fluid.
- The pressure resistant sensor rod is installed into a bore in the piston rod.
- The base unit is mounted by means of only 3 screws. It is the only part that needs to be replaced if servicing is required, i.e. the hydraulic circuit remains closed. For more information see chapter chapter "4.8 Replacement of sensor" on page 29.
- Note the fastening torque of
 - HD: 65 Nm
 - HL: 50 Nm
 - HP: 55 Nm
- Seat the flange contact surface completely on the cylinder mounting surface.
- The cylinder manufacturer determines the pressure-resistant gasket (copper gasket, O-ring, etc.).
- The position magnet should not grind on the sensor rod.
- The piston rod drilling for RFV sensors with pressure rod (outer diameter 12.7 mm (0.5 in.)) is ≥ 16 mm (≥ 0.63 in.). The borehole depends on the pressure and piston speed.
- Adhere to the information relating to operating pressure.
- Protect the sensor rod against wear.

Hydraulics sealing when using an RFV sensor in a pressure rod HD/HL/HP

There are two ways to seal the flange contact surface (Fig. 17):

1. A sealing by using an O-ring (e.g. 22.4 × 2.65 mm (0.88 × 0.1 in.), 25.07 × 2.62 mm (0.99 × 0.1 in.)) in a cylinder end cap groove.
2. A sealing by using an O-ring in the flange undercut.
 For threaded flange (3/4"-16 UNF-3A) »S«: O-ring 16.4 × 2.2 mm (0.65 × 0.09 in.) (part no. 560 315)
 For threaded flange (M18×1.5-6g) »M«: O-ring 15.3 × 2.2 mm (0.60 × 0.09 in.) (part no. 401 133)

In the case of threaded flange M18×1.5-6g provide a screw hole based on ISO 6149-1 (Fig. 18). See ISO 6149-1 for further information.

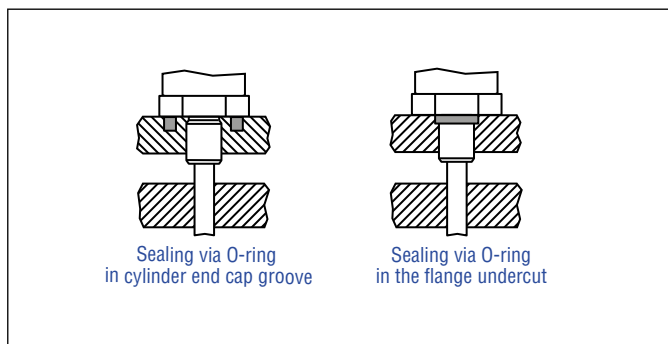

Fig. 17: Possibilities of sealing

For additional information about the accessories HFP profile and pressure rod HD/HL/HP see the accessories catalog (document part number: [551444](#)).

Replacing an R-Series 2004 RF-C with an R-Series V RFV-B.

If you are replacing the R-Series 2004 RF-C base unit with the R-Series V RFV-B base unit, note the following points:

- The R-Series 2004 RF-C base unit is attached to the system with two screws. The R-Series V RFV-B base unit is mounted to the machine with three screws.
- Therefore, we recommend using the adapter plate kit 255198. The adapter plate is used to mount the base unit RFV-B with three screws to the existing hole pattern with two screws.
 - Fasten the adapter plate to the existing hole pattern using the two M4×6 (A/F 2.5) hexagon socket screws with a tightening torque of 1.4 Nm. Ensure that the O-ring is correctly seated between the system and the adapter plate. Secure the screws with Loctite 243.
 - Place the RFV-B base unit on the adapter plate.
 - Attach the grounding lug to one screw of the base unit.
 - Screw the RFV-B base unit to the adapter plate using the three M4×59 hexagon socket screws (A/F 2.5) with a tightening torque of 1.4 Nm. Ensure that the O-ring is correctly seated between the base sensor and the adapter plate. Secure the screws with Loctite 243.
- The adapter plate has a thickness of 5 mm. Order the RFV-B base unit with the addition H003 to compensate for the thickness of the adapter plate: RFV-B-xxxxxx-...-H003

Notice for metric threaded flanges									
Thread (d ₁ × P)	d ₂	d ₃	d ₄	d ₅ +0.1 0	L ₁ +0.4 0	L ₂	L ₃	L ₄	Z° ±1°
RFV-M / optional pressure rod HD									
M18×1.5-6g	55	≥ 16	24.5	19.8	2.4	28.5	2	26	15°

Controlling design dimensions are in millimeters

Fig. 18: Notice for metric threaded flange M18×1.5-6g based on DIN ISO 6149-1

4.5 Installation and design of Temposonics® RDV

RDV with bottom cable entry, example: Connector D56 (connector outlet)

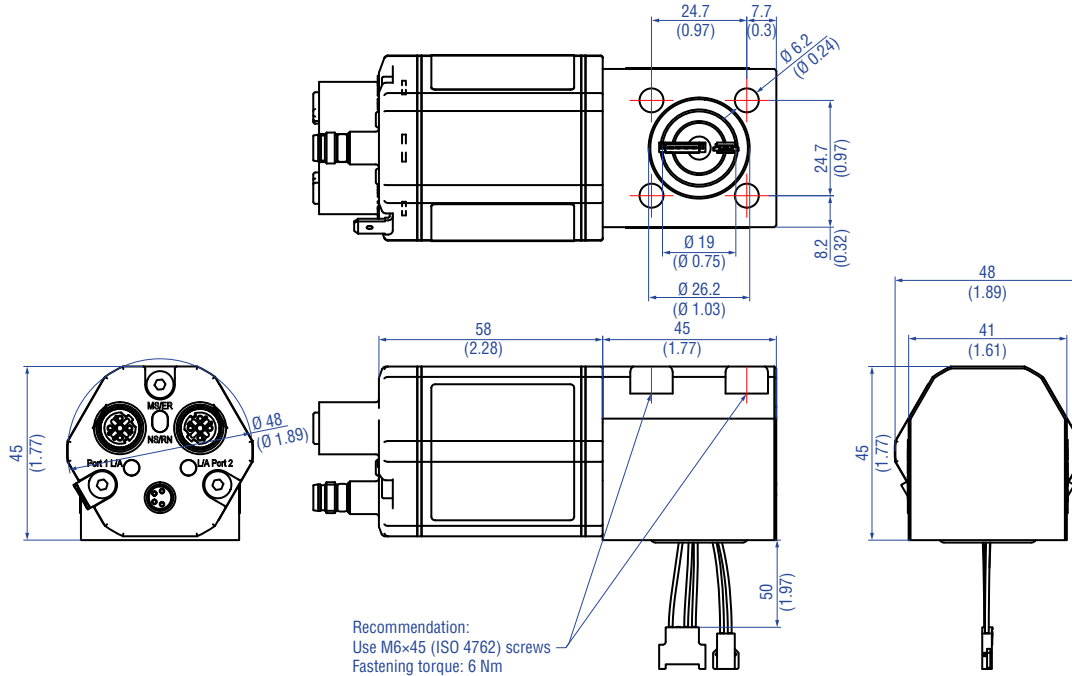

RDV with side cable entry, example: Connector D58 (connector outlet)

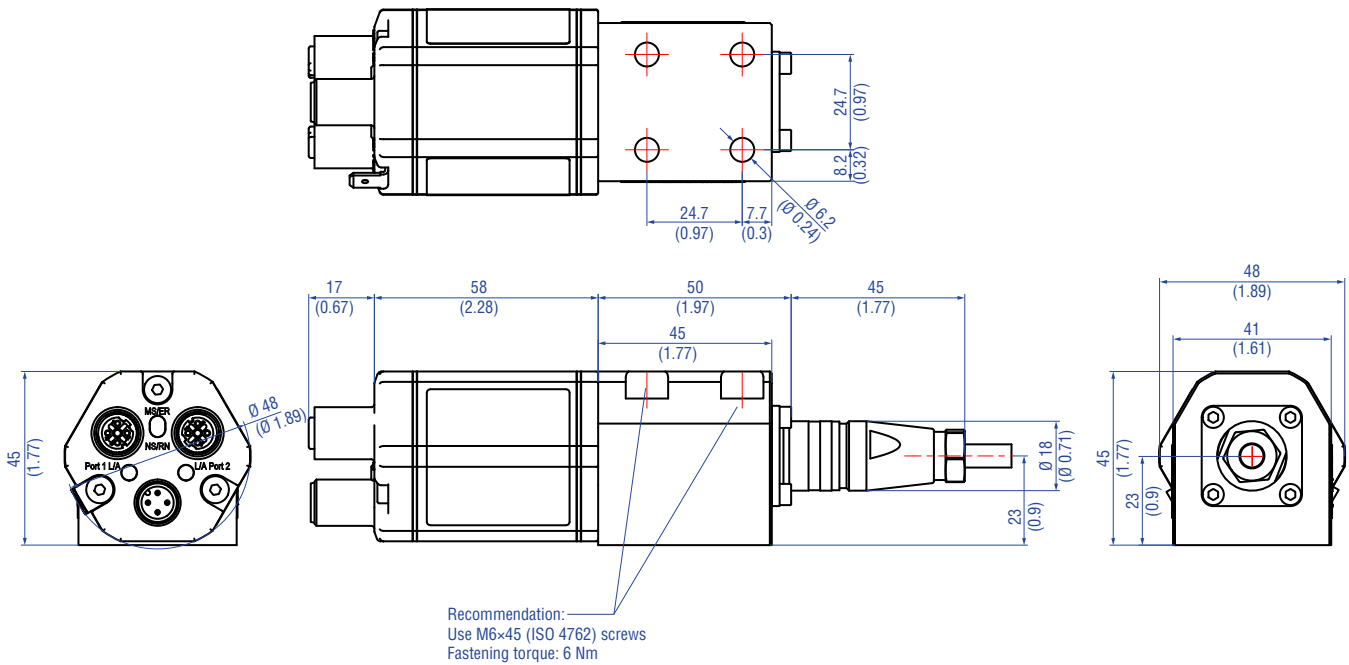

Controlling design dimensions are in millimeters and measurements in () are in inches

Fig. 19: Temposonics® RDV sensor electronics housing

Threaded flange »C« & »D« (for bottom or side cable entry)

PUR cable:

Ø 6 (Ø 0.24)

Bending radius:

> 24 (> 0.94)

Cable length (bottom cable entry):

65/170/230/350

(2.6/6.7/9.1/13.8)

Cable length (side cable entry):

250/400/600

(9.8/15.7/23.6)

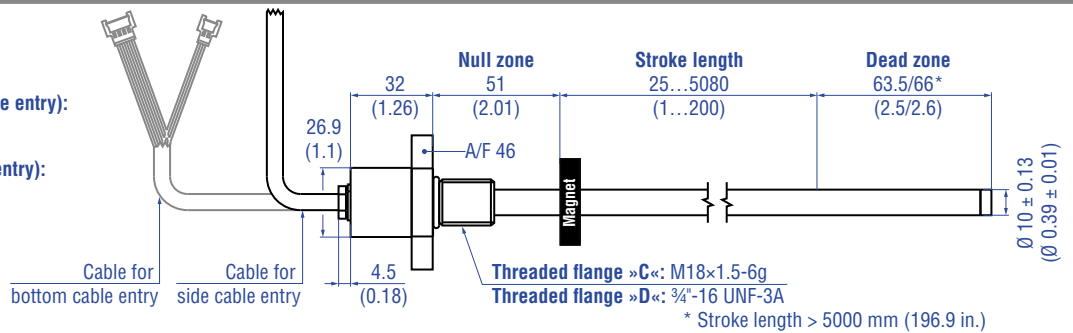

* Stroke length > 5000 mm (196.9 in.)

Threaded flange »M« (for bottom or side cable entry)

PUR cable:

Ø 6 (Ø 0.24)

Bending radius:

> 24 (> 0.94)

Cable length (bottom cable entry):

65/170/230/350

(2.6/6.7/9.1/13.8)

Cable length (side cable entry):

250/400/600

(9.8/15.7/23.6)

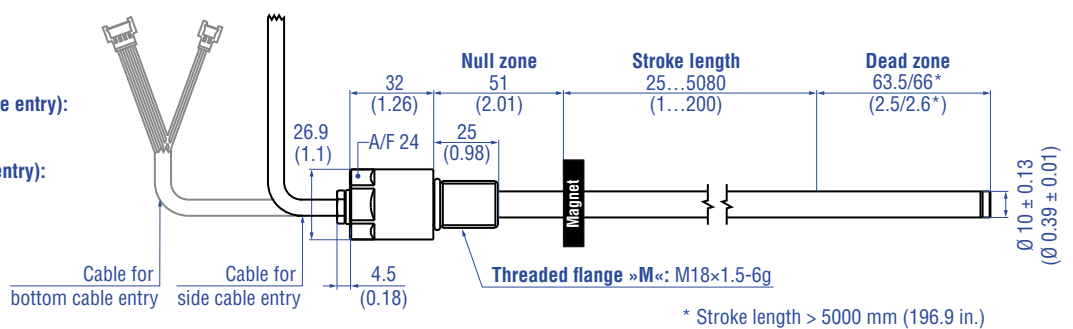

* Stroke length > 5000 mm (196.9 in.)

Threaded flange »T« (for bottom or side cable entry)

PUR cable:

Ø 6 (Ø 0.24)

Bending radius:

> 24 (> 0.94)

Cable length (bottom cable entry):

65/170/230/350

(2.6/6.7/9.1/13.8)

Cable length (side cable entry):

250/400/600

(9.8/15.7/23.6)

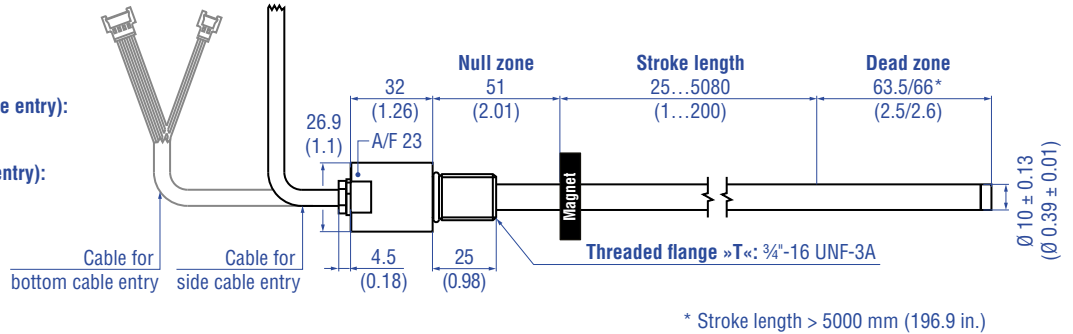

* Stroke length > 5000 mm (196.9 in.)

Pressure fit flange »S« (for bottom or side cable entry)

PUR cable:

Ø 6 (Ø 0.24)

Bending radius:

> 24 (> 0.94)

Cable length (bottom cable entry):

65/170/230/350

(2.6/6.7/9.1/13.8)

Cable length (side cable entry):

250/400/600

(9.8/15.7/23.6)

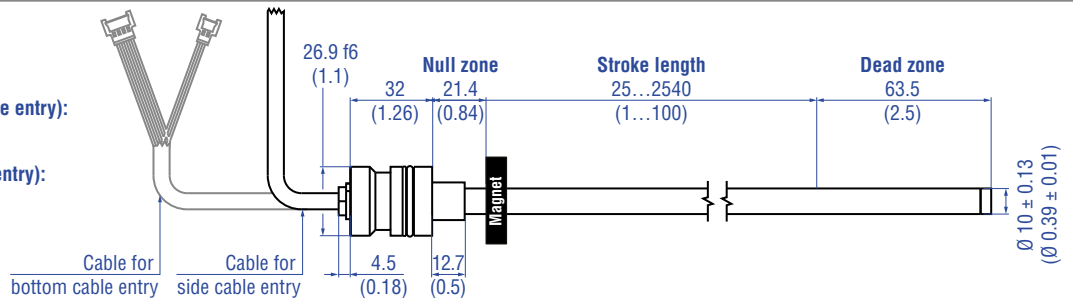

Controlling design dimensions are in millimeters and measurements in () are in inches

Fig. 20: Temposonics® RDV flanges

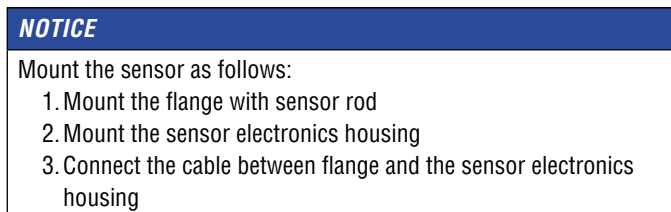
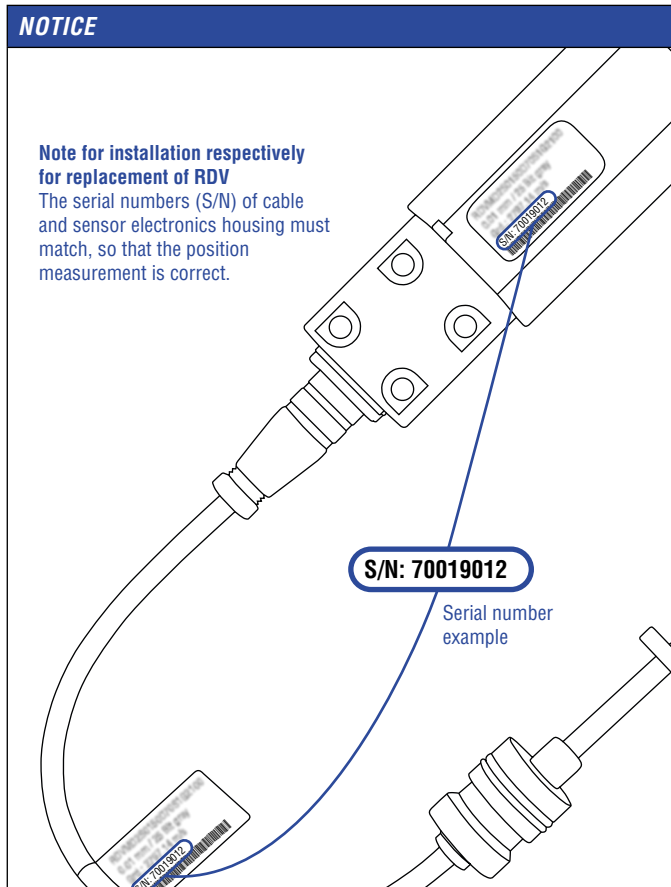

The steps mentioned above will be explained in the following sections.

4.5.1 Installation of RDV with threaded flange

Fix the sensor rod via threaded flange M18×1.5-6g or ¾"-16 UNF-3A.

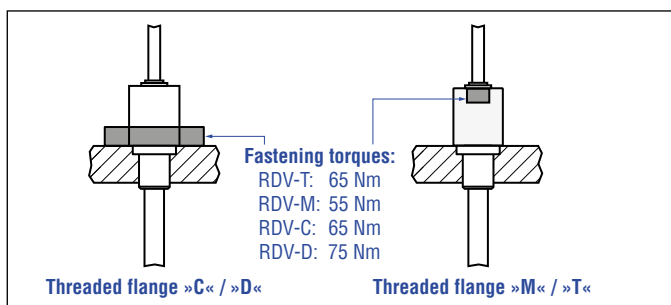

Fig. 21: Mounting example of threaded flange »C« / »D«, »M« / »T«

Installation of a rod-style sensor in a fluid cylinder

The rod-style version has been developed for direct stroke measurement in a fluid cylinder. Mount the sensor via threaded flange or a hex nut.

- Mounted on the face of the piston, the position magnet travels over the rod without touching it and indicates the exact position through the rod wall – independent of the hydraulic fluid.
- The pressure resistant sensor rod is installed into a bore in the piston rod.

Hydraulics sealing

There are two ways to seal the flange contact surface (Fig. 22):

1. Sealing via an O-ring (e.g. 22.4 × 2.65 mm, 25.07 × 2.62 mm) in a cylinder end cap groove (for threaded flange »C« / »D«)
2. Sealing via an O-ring 16.4 × 2.2 mm (part no. 560 315) in the flange undercut.

For threaded flange (¾"-16 UNF-3A) »D« / »T«:

O-ring 16.4 × 2.2 mm (0.65 × 0.09 in.) (part no. 560 315)

For threaded flange (M18×1.5-6g) »C« / »M«:

O-ring 15.3 × 2.2 mm (0.60 × 0.09 in.) (part no. 401 133)

In the case of threaded flange M18×1.5-6g provide a screw hole based on ISO 6149-1 (Fig. 23). See ISO 6149-1 for further information.

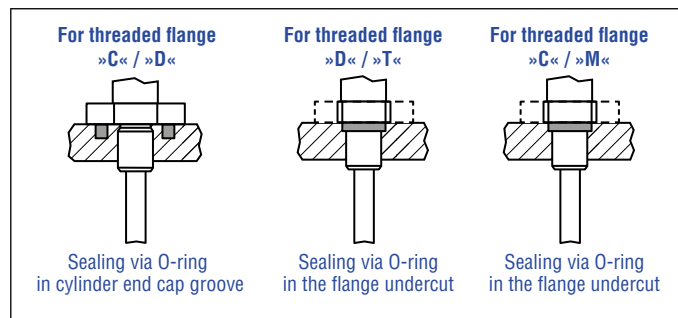

Fig. 22: Possibilities of sealing

- Note the fastening torques:
RDV-T: 65 Nm
RDV-M: 55 Nm
RDV-C: 65 Nm
RDV-D: 75 Nm
- Seat the flange contact surface completely on the cylinder mounting surface.
- The cylinder manufacturer determines the pressure-resistant gasket (copper gasket, O-ring, etc.).
- The position magnet should not grind on the sensor rod.
- The piston rod drilling ($\geq \varnothing 13$ mm ($\geq \varnothing 0.51$ in.)) depends on the pressure and piston speed.
- Adhere to the information relating to operating pressure.
- Protect the sensor rod against wear.

Notice for metric threaded flanges									
Thread (d ₁ × P)	d ₂	d ₃	d ₄	d ₅ +0.1 0	L ₁ +0.4 0	L ₂	L ₃	L ₄	Z° ±1°
RDV-C									
M18×1.5-6g	55	≥ 13	24.5	19.8	2.4	28.5	2	26	15°
RDV-M									
M18×1.5-6g	30	≥ 13	24.5	19.8	2.4	28.5	2	26	15°

Controlling design dimensions are in millimeters

Fig. 23: Notice for metric threaded flange M18×1.5-6g based on DIN ISO 6149-1

4.5.2 Installation of RDV with pressure fit flange

Cylinder mounting

Install the rod using the pressure fit flange. Seal it off by means of the O-ring and the back-up ring. Block the pressure fit flange using a shoulder screw (Fig. 24). For details of the pressure fit flange »S« see Fig. 25. Also note the mounting examples in Fig. 26 and Fig. 27.

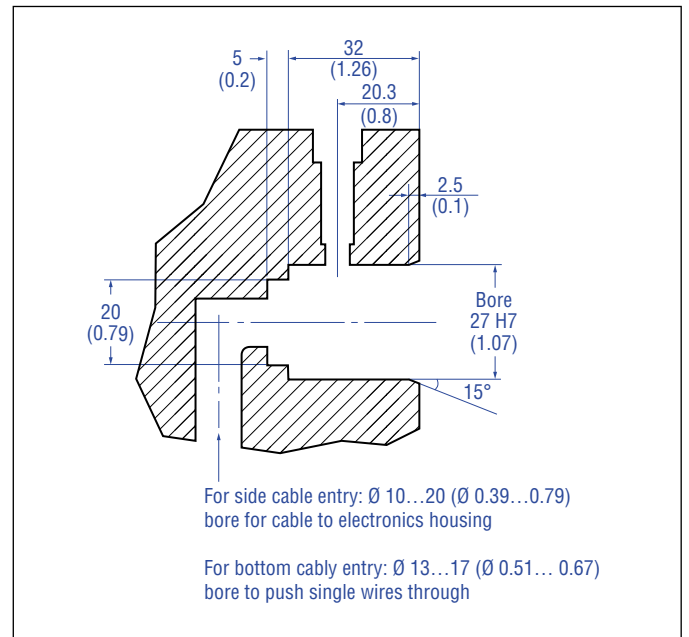

Fig. 24: Example of mounting detail: Shoulder screw 8-M6 (ISO 7379) with internal hexagon

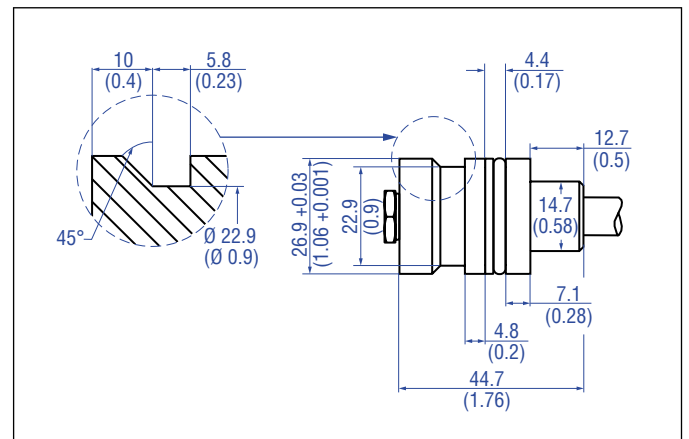

Fig. 25: Pressure fit flange »S« details

Note for cylinder installation:

- The position magnet should not grind on the sensor rod.
- The piston rod drilling ($\geq \text{Ø } 13 \text{ mm}$ ($\geq \text{Ø } 0.51 \text{ in.}$)) depends on the pressure and piston speed.
- Adhere to the information relating to operating pressure.
- Protect the sensor rod against wear.

4.5.4 Installation of RDV's sensor electronics housing

The following section explains the connection of an RDV sensor with bottom cable entry (Fig. 26) and side cable entry (Fig. 27) based on RDV-S. The sensor electronics of RDV sensors with threaded flange are mounted in the same way.

Sensor electronics with bottom cable entry

Connect the rod via the connector to the sensor electronics. Mount the sensor electronics so that you can lead the cables below the bottom of the housing. Thus the sensor system including the connection cables is fully encapsulated and protected against external disturbances (Fig. 26). Note the bending radius of the cable if you run the cable between sensor electronics and rod (see Fig. 20).

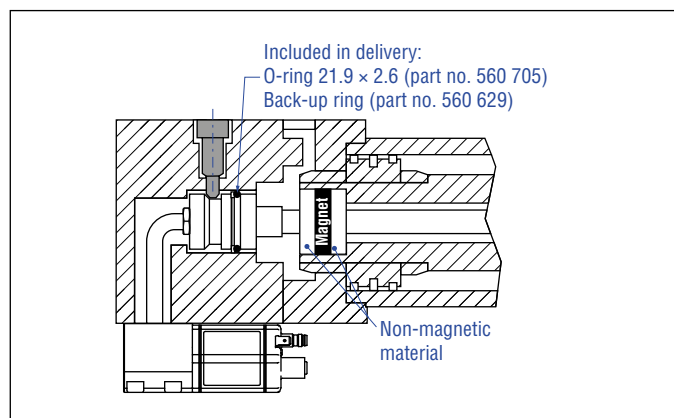

Fig. 26: Mounting example of pressure fit flange »S« and sensor electronics with bottom cable entry

Sensor electronics with side cable entry

Connect the rod via the cable to the sensor electronics on the side. Encapsulate the sensor system including the connection cables (Fig. 27). Note the bending radius of the cable if you run the cable between sensor electronics and rod (see Fig. 20).

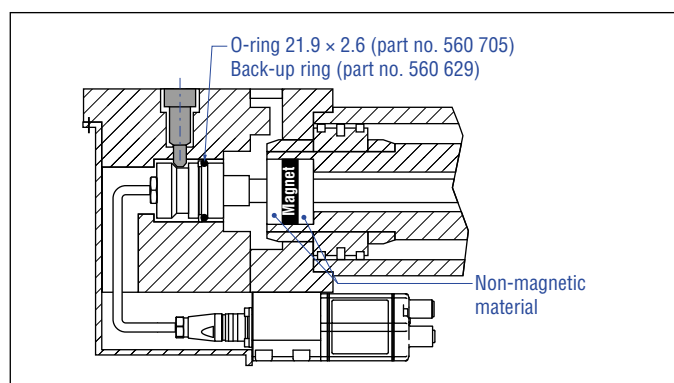

Fig. 27: Mounting example of pressure fit flange »S« and sensor electronics with side cable entry

NOTICE

To fulfill the requirements of the EMC standards for emission and immunity the following points are necessary:

- The sensor electronics housing has to be connected to machine ground (Fig. 47).
- The cable between the sensor and the electronics must be integrated into a metallic housing.

Connect the flange to the sensor electronics housing via the molex connectors for bottom cable entry respectively via the 6 pin cable for side cable entry.

4.5.3 Mounting of sensor electronics housing

Mount the sensor electronics housing with 4 × M6×45 (ISO 4762) screws via the mounting block. Note the fastening torque of 6 Nm.

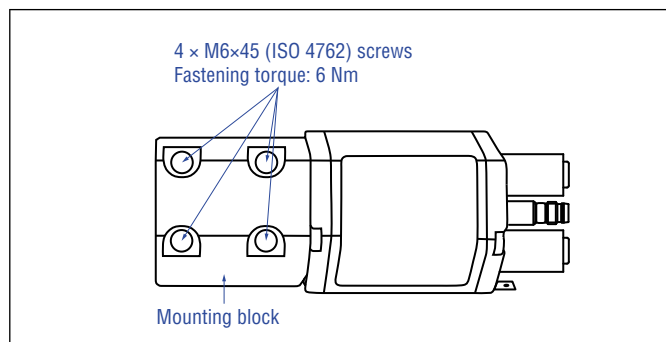

Fig. 28: Mounting of RDV's sensor electronics housing (example of bottom cable entry)

4.6 Magnet installation

Typical use of magnets



Magnet	Typical sensors	Benefits
	Rod model (RH5, RFV, RDV)	<ul style="list-style-type: none"> Rotationally symmetrical magnetic field
	Profile & rod models (RP5, RH5, RFV, RDV)	<ul style="list-style-type: none"> Height tolerances can be compensated, because the magnet can be lifted off
	Profile & rod models (RP5, RH5, RFV, RDV)	<ul style="list-style-type: none"> Height tolerances can be compensated, because the magnet can be lifted off
	Profile models (RP5)	<ul style="list-style-type: none"> The magnet is guided by the profile The distance between the magnet and the waveguide is strictly defined Easy coupling via the ball joint

Fig. 29: Typical use of magnets

Mounting ring magnets, U-magnets & block magnets

Install the magnet using non-magnetic material for mounting device, screws, spacers etc.. The magnet must not grind on the sensor rod. Alignment errors are compensated via the air gap.

- Permissible surface pressure: Max. 40 N/mm² (only for ring magnets and U-magnets)
- Fastening torque for M4 screws: 1 Nm; use washers, if necessary
- Minimum distance between position magnet and any magnetic material has to be 15 mm (0.6 in.) (Fig. 32).
- If no other option exists and magnetic material is used, observe the specified dimensions (Fig. 32).

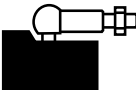
NOTICE

- Mount ring magnets and U-magnets concentrically.
- Mount block magnets centrically over the sensor rod or the sensor profile. The maximum permissible air gap must not be exceeded (Fig. 30/ Fig. 31).
- Take care to mount the primary sensor axis in parallel to the magnet path in order to avoid damage to the carriage, magnet and sensor rod/sensor profile.

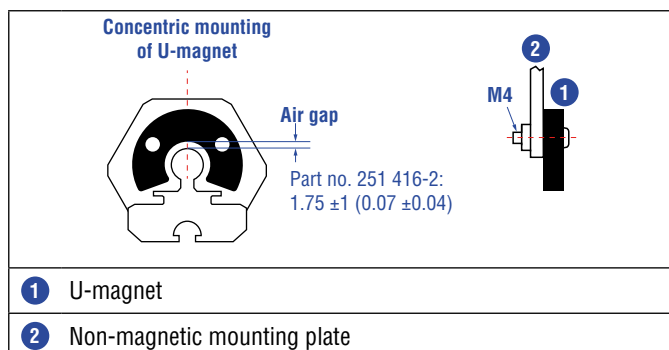

Fig. 30: Mounting of U-magnet (part no. 251 416-2)

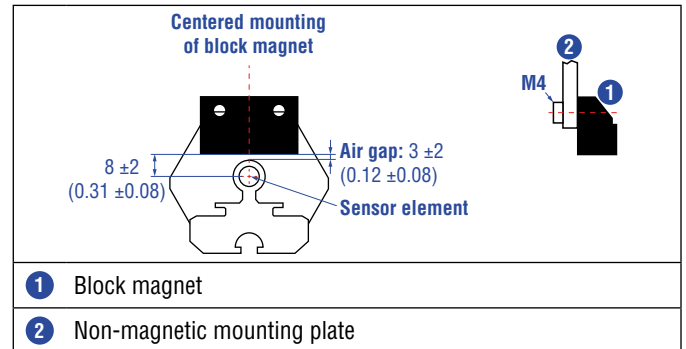

Fig. 31: Mounting of block magnet (part no. 403 448)

Magnet mounting with magnetic material

When using magnetic material the dimensions of Fig. 32 must be observed.

- A.** If the position magnet aligns with the drilled piston rod
- B.** If the position magnet is set further into the drilled piston rod, install another non-magnetic spacer (e.g. part no. 400 633) above the magnet.

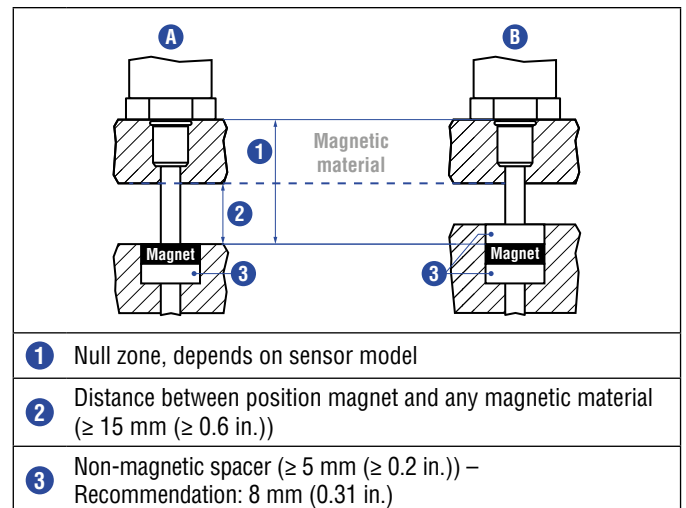

Fig. 32: Installation with magnetic material

Rod sensors with stroke lengths ≥ 1 meter (3.3 ft.)

Support horizontally installed sensors with a stroke length from 1 meter (3.3 ft.) mechanically at the rod end. Without using a support, the sensor rod bends over and the rod and the position magnet may be damaged. A false measurement result is also possible. Longer rods require evenly distributed mechanical support over the entire length (e.g. part no. 561 481). Use an U-magnet (Fig. 33) for measurement.

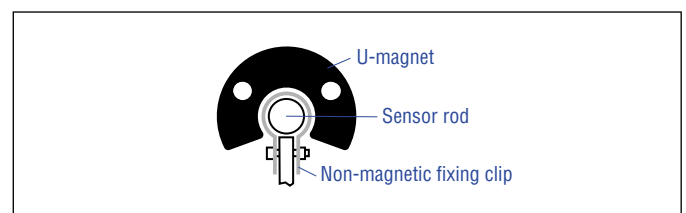

Fig. 33: Example of sensor support (part no. 561 481)

Controlling design dimensions are in millimeters and measurements in () are in inches

Start- and end positions of the position magnets

Consider the start and end positions of the position magnets during the installation. To ensure that the entire stroke length is electrically usable, the position magnet must be mechanically mounted as follows.

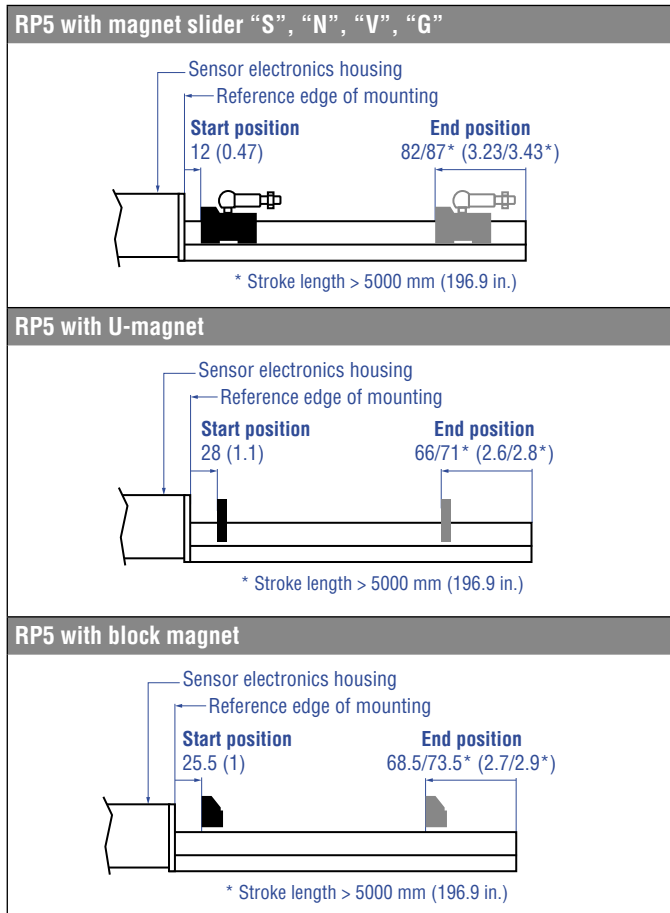

Fig. 34: Start- and end positions of magnets RP5

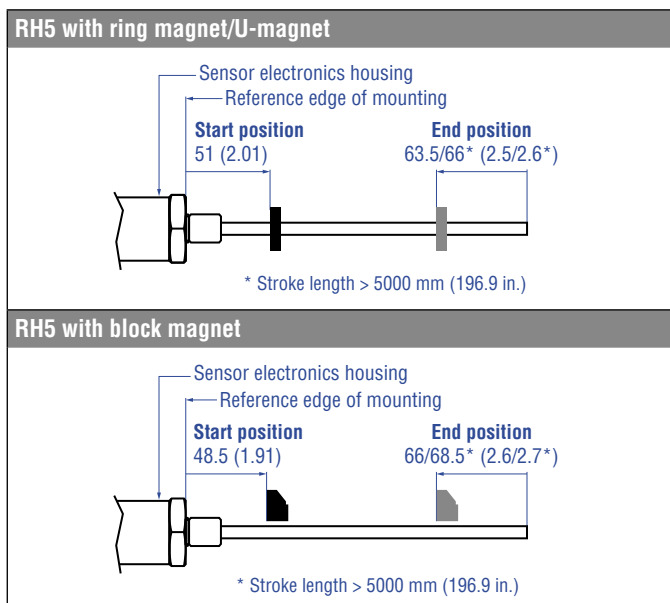

Fig. 35: Start- and end positions of magnets RH5

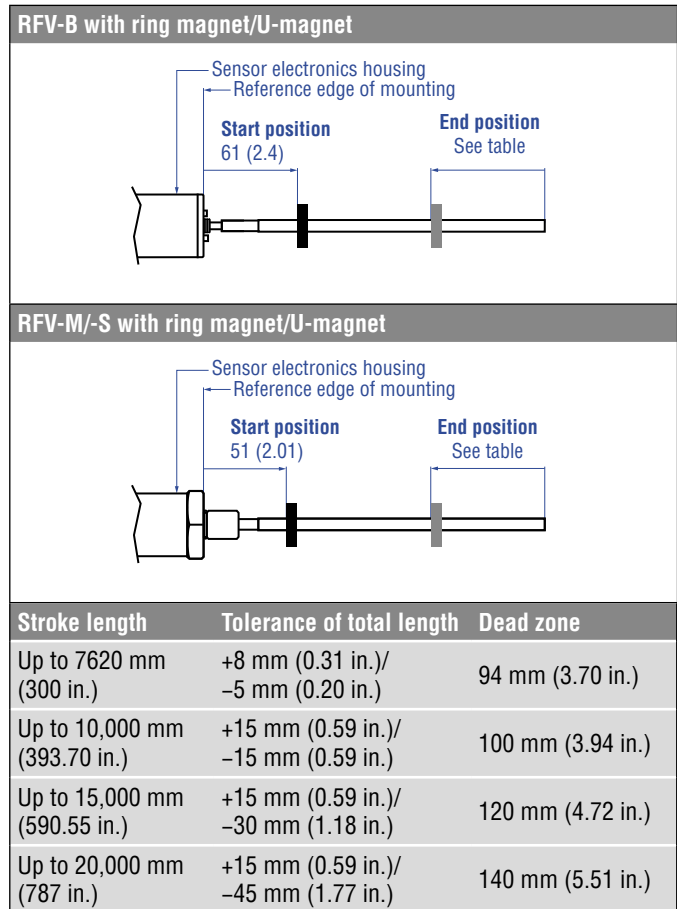

Fig. 36: Start- and end positions of magnets RFV with ring- and U-magnets

Controlling design dimensions are in millimeters and measurements in () are in inches

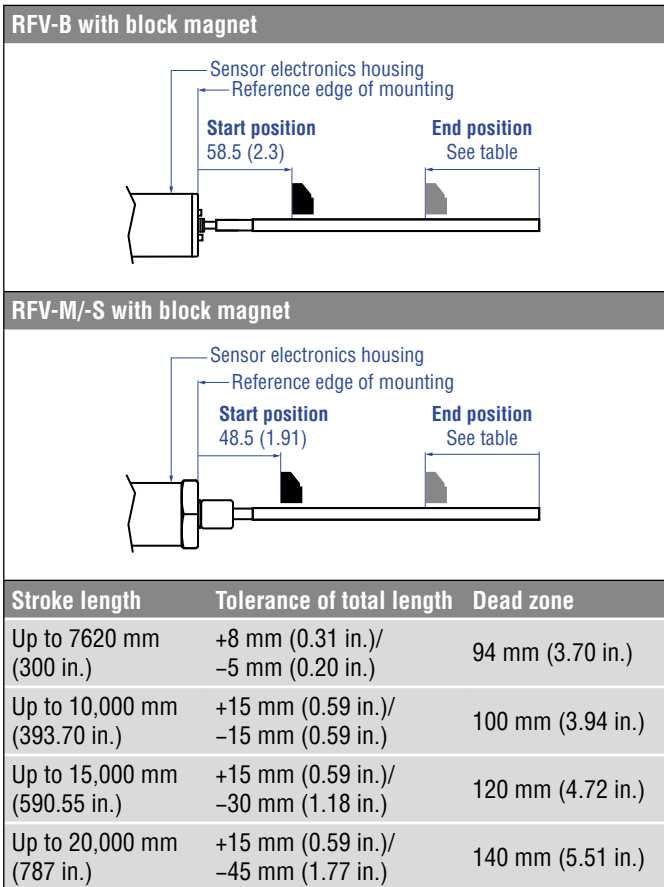

Fig. 37: Start- and end positions of magnets RFV with block magnets

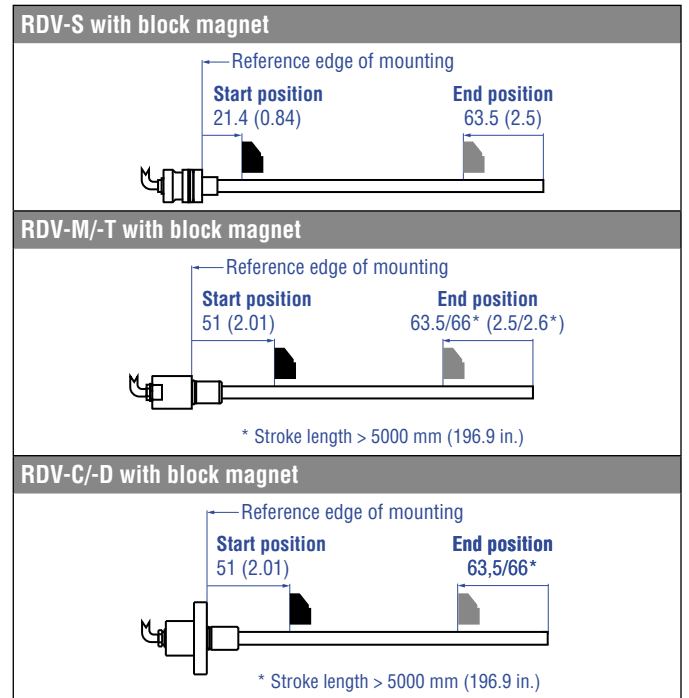

Fig. 39: Start- and end positions of magnets RDV with block magnets

NOTICE
On all sensors, the areas left and right of the active stroke length are provided for null and dead zone. These zones should not be used for measurement, however the active stroke length can be exceeded.

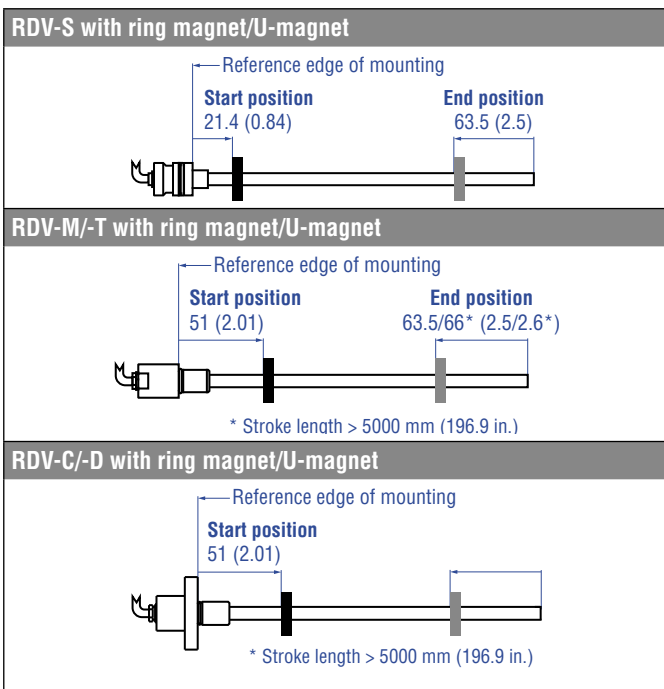

Fig. 38: Start- and end positions of magnets RDV with ring- and U-magnets

Controlling design dimensions are in millimeters and measurements in () are in inches

Multi-position measurement

The minimum distance between the magnets is 75 mm (3 in.).

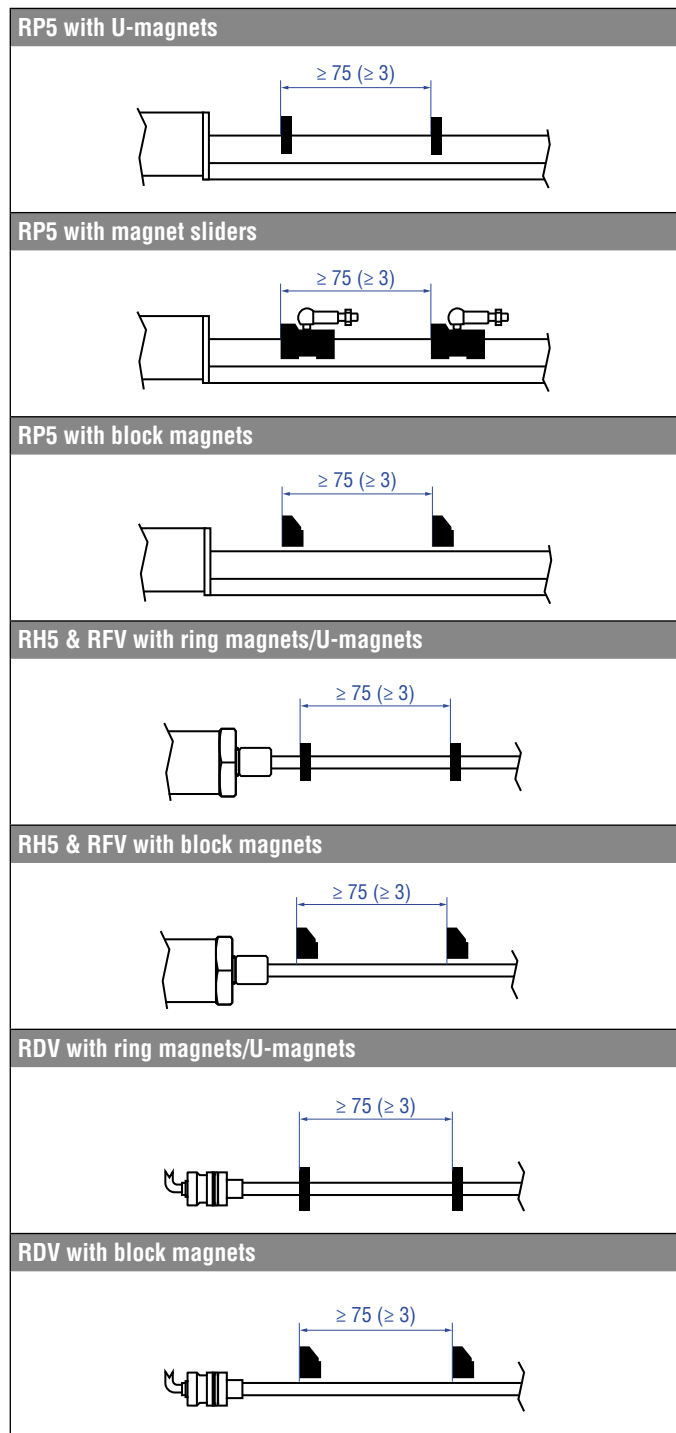

Fig. 40: Minimum distance for multi-position measurement

NOTICE

Use magnets of the same type for multi-position measurement. Do not fall below the minimum distance between the magnets of 75 mm (3 in.) for multi-position measurement. Contact Temposonics if you need a magnet distance < 75 mm (3 in.).

4.7 Alignment of the magnet with the option “Internal linearization”

The internal linearization offers improved linearity of the sensor. The option must be specified in the order code of the sensor. The internal linearization is set for the sensor during production. A sensor with internal linearization is delivered with the magnet with which the sensor was calibrated during production. In order to achieve the best possible result, Temposonics recommends to operate the sensor with the supplied magnet.

For the internal linearization, the following magnets can be used:

- Ring magnet OD33 (part no. 253 620), only for RH5 and RDV
- U-magnet OD33 (part no. 254 226)
- Ring magnet OD24.4 (part no. 253 621), only for RH5 and RDV
- Magnet slider S (part no. 252 182), only for RP5
- Magnet slider N (part no. 252 183), only for RP5
- Magnet slider V (part no. 252 184), only for RP5
- Magnet slider G (part no. 253 421), only for RP5

The ring magnet and U-magnet will be marked for the internal linearization. During the installation, the magnets have to be aligned to the sensor electronic housing or the flange of the RDV, see Fig. 41, Fig. 42, Fig. 43 and Fig. 44.

For RH5 PROFINET sensors with ring magnet/U-magnets applies:

- Install the magnet until the marking on the magnet points to the sensor electronics housing.
- The marking on the magnet points to the same direction as the elongated status LED in the lid of the sensor electronics housing.

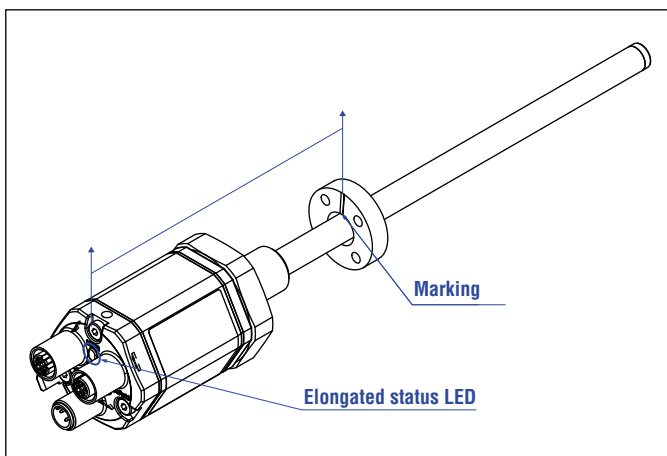

Fig. 41: Alignment of the ring magnet on the RH5 PROFINET with internal linearization

For RP5 PROFINET sensors with U-magnet applies:

- Install the magnet until the marking on the magnet points to the sensor electronics housing.
- The marking on the magnet points to the same direction as the elongated status LED in the lid of the sensor electronics housing.

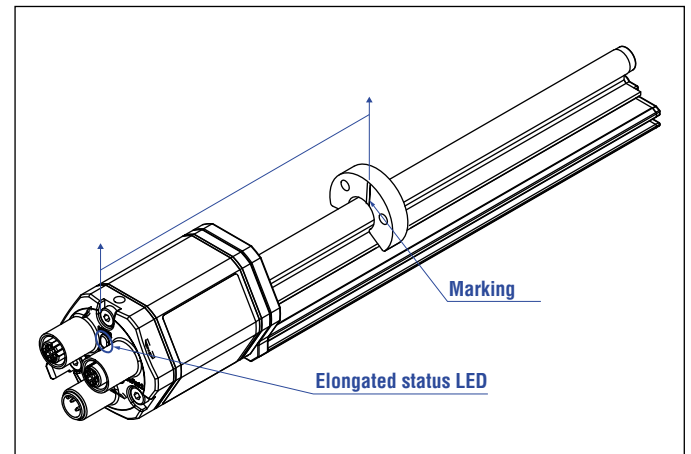

Fig. 42: Magnet alignment of U-magnet for RP5 PROFINET with internal linearization

For RP5 PROFINET sensors with magnet slider applies:

- ① Install the magnet sliders “S”, “N” and “G” until the additional hole in the magnet points towards the sensor electronics housing.
- ② Install the magnet slider “V” until the joint points to the end of the profile.

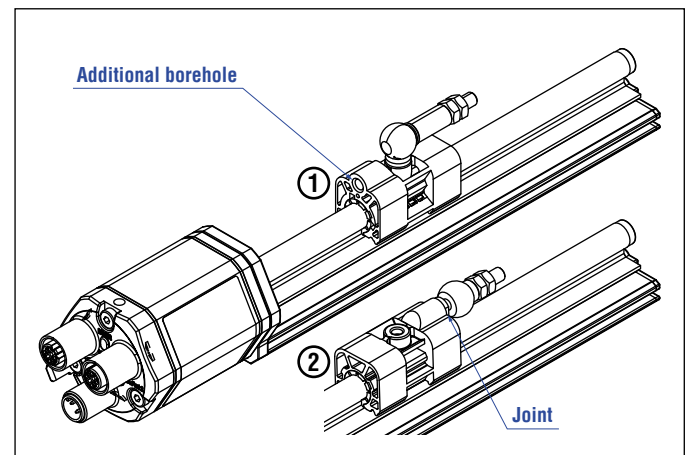

Fig. 43: Magnet alignment of magnet slider for RP5 PROFINET with internal linearization

For RDV PROFINET sensors with ring magnet/U-magnets applies:

- Install the magnet so that the marking on the magnet faces the sensor flange.
- The marking on the magnet points in the same direction as the marking on the sensor flange.

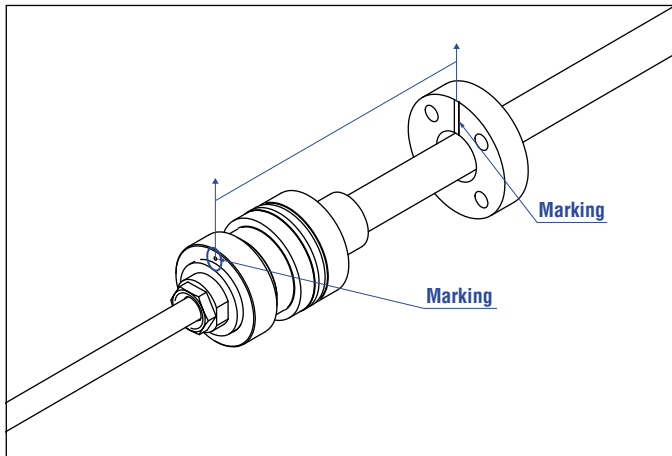

Fig. 44: Magnet alignment of magnet slider for RDV PROFINET with internal linearization

The internal linearization of the sensor is carried out under the following conditions:

- Supply voltage +24 VDC \pm 0.5
- Operating time > 30 min
- No shock and no vibration
- Eccentricity of the position magnet to central axis of the sensor < 0.1 mm

NOTICE

The generated linearization might deviate from the linearity tolerances regarding different environmental conditions. In addition, the use of a different position magnet or more position magnets may cause differences.

4.8 Replacement of sensor

The base unit of the sensor model RH5-B is replaceable as shown in Fig. 45 and Fig. 46 for the sensor designs »M«, »S« and »T«. The sensor can be replaced without interrupting the hydraulic circuit. This also applies to the RFV-B sensor, which is installed in the optional HD, HL and HP pressure rod.

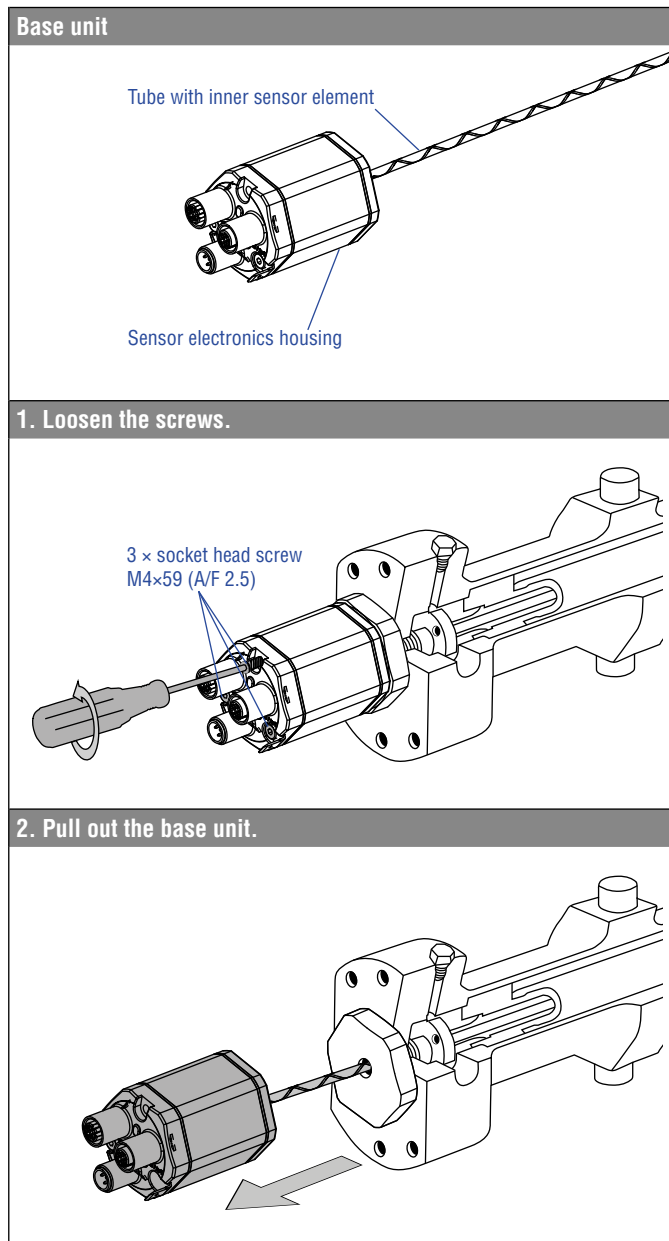

Fig. 45: Replacement of the base unit (e.g. RH5 sensor), part 1

3. Insert the new base unit.
Mount the ground lug on a screw.
Tighten the screws.

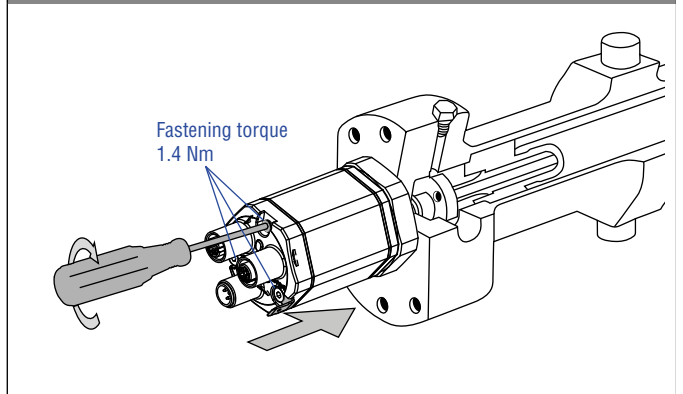

Fig. 46: Replacement of the base unit (e.g. RH5 sensor), part 2

NOTICE

- When replacing the base unit, make sure that no humidity enters the sensor tube. This may damage the sensor.
- Secure the base unit screws, e.g. using Loctite 243, before re-installing.
- If the R-Series V replaces a predecessor model of the R-Series, the plastic tube in the sensor rod must be removed.
- Make sure the O-ring is correctly fitted between the flange and the base unit.

4.9 Electrical connections

Placement of installation and cabling have decisive influence on the sensor's electromagnetic compatibility (EMC). Hence correct installation of this active electronic system and the EMC of the entire system must be ensured by using suitable metal connectors, shielded cables and grounding. Overvoltages or faulty connections can damage its electronics despite protection against wrong polarity.

NOTICE

1. Do not mount the sensors in the area of strong magnetic or electric noise fields.
2. Never connect/disconnect the sensor when voltage is applied.

Instructions for connection

- Use low-resistant twisted pair and shielded cables. Connect the shield to ground externally via the controller equipment.
- Keep control and signal cables separate from power cables and sufficiently far away from motor cables, frequency inverters, valve lines, relays, etc..
- Use only connectors with metal housing and connect the shielding to the connector housing.
- Keep the connection surface at both shielding ends as large as possible. Connect the cable clamps to function as a ground.
- Keep all non-shielded leads as short as possible.
- Keep the earth connection as short as possible with a large cross section. Avoid ground loops.
- With potential differences between machine and electronics earth connections, no compensating currents are allowed to flow across the cable shielding.
Recommendation:
Install potential compensating leads with large cross section, or use cables with separate double shielding, and connect only one end of the shield.
- Use only stabilized power supplies in compliance with the specified electrical ratings.

Grounding of profile and rod sensors

Connect the sensor electronics housing to machine ground. Ground R-Series V sensors via ground lug as shown in Fig. 47. In addition you can ground the sensor types RH5 and RFV via thread.

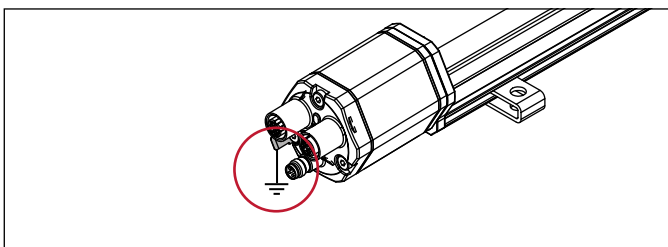

Fig. 47: Grounding via ground lug on the example of an RP5 sensor

Connector wiring

Connect the sensor directly to the control system, indicator or other evaluating systems as follows:

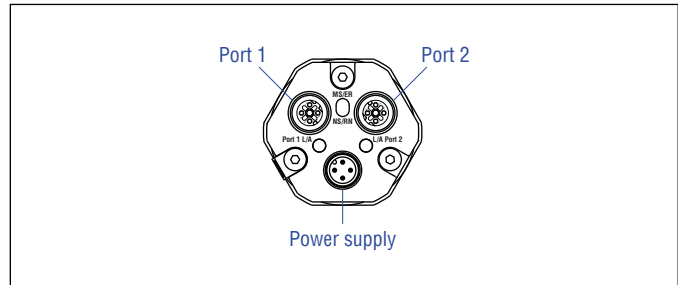

Fig. 48: Location of connections

D58		
Port 1 – Signal		
M12 female connector (D-coded)	Pin	Function
<p>View on sensor</p>	1	Tx (+)
	2	Rx (+)
	3	Tx (-)
	4	Rx (-)
Port 2 – Signal		
M12 female connector (D-coded)	Pin	Function
<p>View on sensor</p>	1	Tx (+)
	2	Rx (+)
	3	Tx (-)
	4	Rx (-)
Power supply		
M12 male connector (A-coded)	Pin	Function
<p>View on sensor</p>	1	+12...30 VDC (±20 %)
	2	Not connected
	3	DC Ground (0 V)
	4	Not connected

Fig. 49: Connector wiring D58



D56		
Port 1 – Signal		
M12 female connector (D-coded)	Pin	Function
 <p>View on sensor</p>	1	Tx (+)
	2	Rx (+)
	3	Tx (-)
	4	Rx (-)
Port 2 – Signal		
M12 female connector (D-coded)	Pin	Function
 <p>View on sensor</p>	1	Tx (+)
	2	Rx (+)
	3	Tx (-)
	4	Rx (-)
Power supply		
M8 male connector	Pin	Function
 <p>View on sensor</p>	1	+12...30 VDC (±20 %)
	2	Not connected
	3	DC Ground (0 V)
	4	Not connected

Fig. 50: Connector wiring D56

4.10 Frequently ordered accessories for RP5 design – Additional options available in our [Accessories Catalog](#) 551 444

Position magnets

			
<p>Magnet slider S, joint at top Part no. 252 182</p> <p>Material: GRP, magnet hard ferrite Weight: Approx. 35 g Operating temperature: -40...+85 °C (-40...+185 °F)</p>	<p>Magnet slider V, joint at front Part no. 252 184</p> <p>Material: GRP, magnet hard ferrite Weight: Approx. 35 g Operating temperature: -40...+85 °C (-40...+185 °F)</p>	<p>Magnet slider N longer ball-joint arm Part no. 252 183</p> <p>Material: GRP, magnet hard ferrite Weight: Approx. 35 g Operating temperature: -40...+85 °C (-40...+185 °F)</p>	<p>Magnet slider G, backlash free Part no. 253 421</p> <p>Material: GRP, magnet hard ferrite Weight: Approx. 25 g Operating temperature: -40...+85 °C (-40...+185 °F)</p>

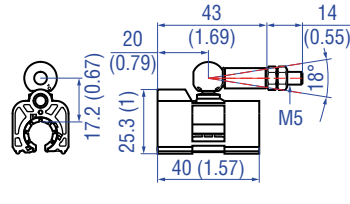
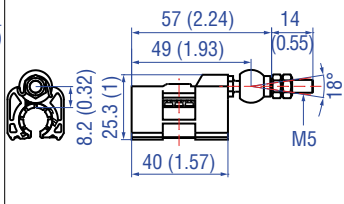
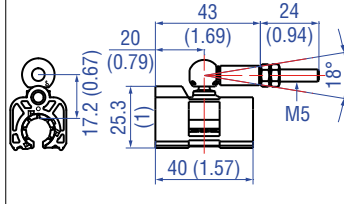
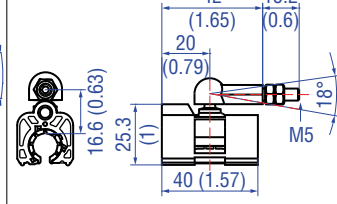
Position magnets

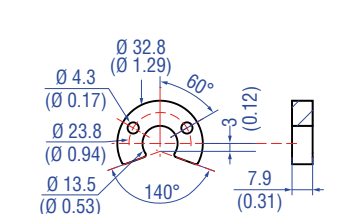

U-magnet OD33
Part no. 251 416-2

Material: PA ferrite GF20
Weight: Approx. 11 g
Surface pressure: Max. 40 N/mm²
Fastening torque for M4 screws: 1 Nm
Operating temperature:
-40...+105 °C (-40...+221 °F)

Marked version for sensors with internal linearization: Part no. 254 226

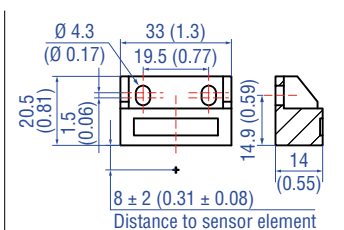

Block magnet L
Part no. 403 448

Material: Plastic carrier with hard ferrite magnet
Weight: Approx. 20 g
Fastening torque for M4 screws: 1 Nm
Operating temperature:
-40...+75 °C (-40...+167 °F)

This magnet may influence the sensor performance specifications for some applications.

Mounting accessories

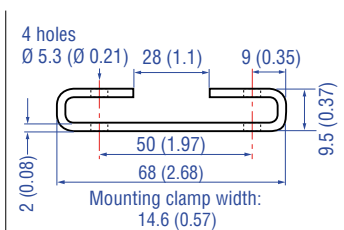

Mounting clamp
Part no. 400 802

Material: Stainless steel (AISI 304)

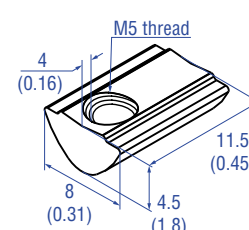

T-nut
Part no. 401 602

Fastening torque for M5 screw: 4.5 Nm

4.11 Frequently ordered accessories for RH5 design – Additional options available in our [Accessories Catalog](#) 551 444

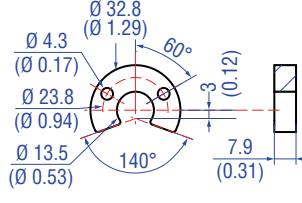
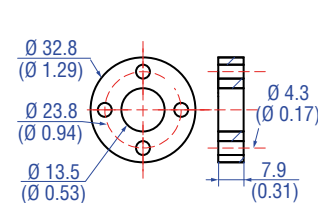
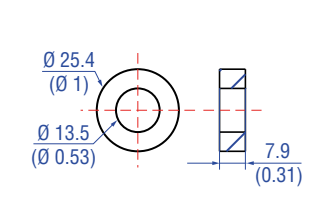
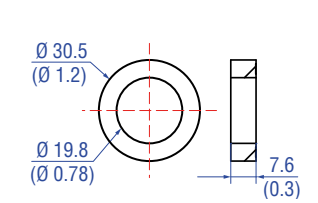
Position magnets			
			
<p>U-magnet OD33 Part no. 251 416-2</p>	<p>Ring magnet OD33 Part no. 201 542-2</p>	<p>Ring magnet OD25.4 Part no. 400 533</p>	<p>Ring magnet Part no. 402 316</p>
<p>Material: PA ferrite GF20 Weight: Approx. 11 g Surface pressure: Max. 40 N/mm² Fastening torque for M4 screws: 1 Nm Operating temperature: -40...+105 °C (-40...+221 °F) Marked version for sensors with internal linearization: Part no. 254 226</p>	<p>Material: PA ferrite GF20 Weight: Approx. 14 g Surface pressure: Max. 40 N/mm² Fastening torque for M4 screws: 1 Nm Operating temperature: -40...+105 °C (-40...+221 °F) Marked version for sensors with internal linearization: Part no. 253 620</p>	<p>Material: PA ferrite Weight: Approx. 10 g Surface pressure: Max. 40 N/mm² Operating temperature: -40...+105 °C (-40...+221 °F) Marked version for sensors with internal linearization: Part no. 253 621</p>	<p>Material: PA ferrite coated Weight: Approx. 13 g Surface pressure: Max. 20 N/mm² Operating temperature: -40...+100 °C (-40...+212 °F)</p>

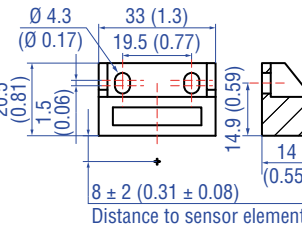
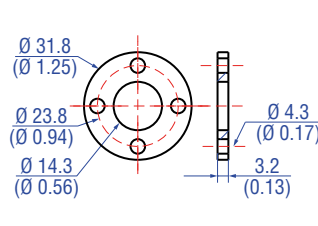
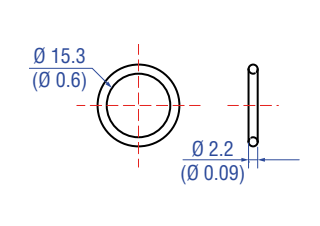
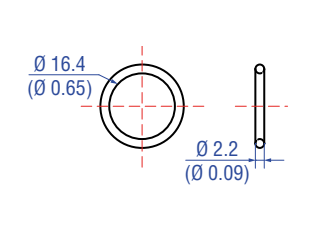
Position magnet	Magnet spacer	O-rings	
			
<p>Block magnet L Part no. 403 448</p>	<p>Magnet spacer Part no. 400 633</p>	<p>O-ring for threaded flange M18×1.5-6g Part no. 401 133</p>	<p>O-ring for threaded flange ¾"-16 UNF-3A Part no. 560 315</p>
<p>Material: Plastic carrier with hard ferrite magnet Weight: Approx. 20 g Fastening torque for M4 screws: 1 Nm Operating temperature: -40...+75 °C (-40...+167 °F) This magnet may influence the sensor performance specifications for some applications.</p>	<p>Material: Aluminum Weight: Approx. 5 g Surface pressure: Max. 20 N/mm² Fastening torque for M4 screws: 1 Nm</p>	<p>Material: Fluoroelastomer Durometer: 75 ± 5 Shore A Operating temperature: -40...+204 °C (-40...+400 °F)</p>	<p>Material: Fluoroelastomer Durometer: 75 ± 5 Shore A Operating temperature: -40...+204 °C (-40...+400 °F)</p>

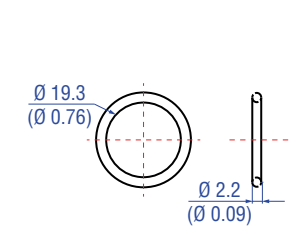
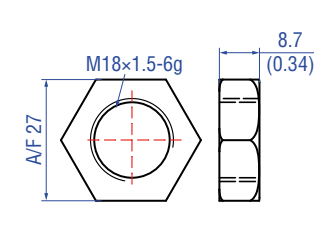
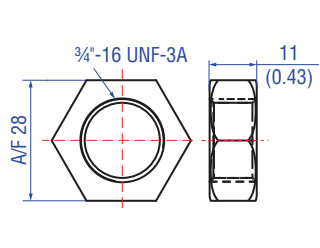
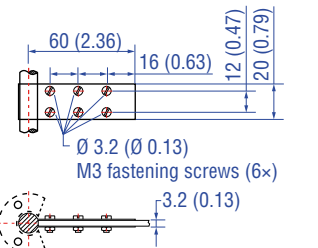
O-ring	Mounting accessories		
			
<p>O-ring for threaded flange M22×1.5-6g Part no. 561 337</p>	<p>Hex jam nut M18×1.5-6g Part no. 500 018</p>	<p>Hex jam nut ¾"-16 UNF-3A Part no. 500 015</p>	<p>Fixing clip Part no. 561 481</p>
<p>Material: FPM Durometer: 75 Shore A Operating temperature: -20...+200 °C (-6...+392 °F)</p>	<p>Material: Steel, zinc plated</p>	<p>Material: Steel, zinc plated</p>	<p>Application: Used to secure sensor rods (Ø 10 mm (Ø 0.39 in.)) when using an U-magnet or block magnet Material: Brass, non-magnetic</p>

4.12 Frequently ordered accessories for RFV design – Additional options available in our [Accessories Catalog](#) 551 444

Position magnets

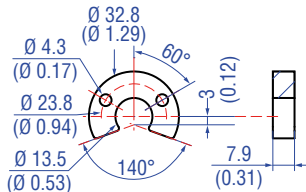
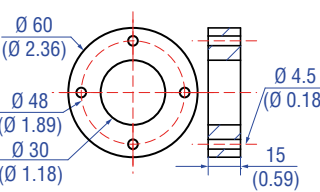
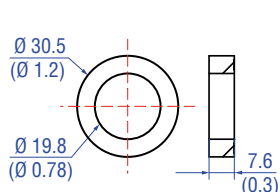
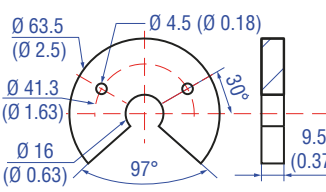
			
<p>U-magnet OD33 Part no. 251 416-2</p> <p>Material: PA ferrite GF20 Weight: Approx. 11 g Surface pressure: Max. 40 N/mm² Fastening torque for M4 screws: 1 Nm Operating temperature: -40...+105 °C (-40...+221 °F)</p>	<p>Ring magnet OD60 Part no. MT0162</p> <p>Material: AlCuMgPb, magnets compound-filled Weight: Approx. 90 g Surface pressure: Max. 20 N/mm² Fastening torque for M4 screws: 1 Nm Operating temperature: -40...+75 °C (-40...+167 °F)</p>	<p>Ring magnet Part no. 402 316</p> <p>Material: PA ferrite coated Weight: Approx. 13 g Surface pressure: Max. 20 N/mm² Operating temperature: -40...+100 °C (-40...+212 °F)</p>	<p>U-magnet OD63.5 Part no. 201 553</p> <p>Material: PA 66-GF30, magnets compound-filled Weight: Approx. 26 g Surface pressure: 20 N/mm² Fastening torque for M4 screws: 1 Nm Operating temperature: -40...+75 °C (-40...+167 °F)</p>

O-rings

Mounting accessories

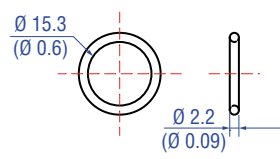
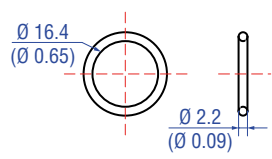
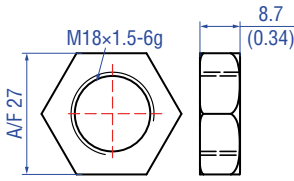
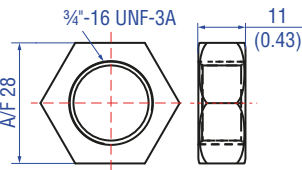
			
<p>O-ring for threaded flange M18x1.5-6g Part no. 401 133</p> <p>Material: Fluoroelastomer Durometer: 75 ± 5 Shore A Operating temperature: -40...+204 °C (-40...+400 °F)</p>	<p>O-ring for threaded flange 3/4-16 UNF-3A Part no. 560 315</p> <p>Material: Fluoroelastomer Durometer: 75 ± 5 Shore A Operating temperature: -40...+204 °C (-40...+400 °F)</p>	<p>Hex jam nut M18x1.5-6g Part no. 500 018</p> <p>Material: Steel, zinc plated</p>	<p>Hex jam nut 3/4-16 UNF-3A Part no. 500 015</p> <p>Material: Steel, zinc plated</p>

Mounting accessories



Threaded flange M18x1.5-6g
Part no. 404 874

Material: Stainless steel 1.4305 (AISI 303)



Threaded flange 3/4-16 UNF-3A
Part no. 404 875

Material: Stainless steel 1.4305 (AISI 303)

Mounting accessories



Pressure rod with threaded flange with flat-face (M18x1.5-6g) and O-ring
 HD [length mm: XXXX] M
 HD [length in.: XXX.X] U

Pressure rod Ø: 12.7 mm (0.5 in.)
 Length: 100...7500 mm (4...295 in.)
 Operating pressure: 350 bar (5076 psi)
 Material flange:
 Stainless steel 1.4305 (AISI 303)
 Material rod:
 Stainless steel 1.4301 (AISI 304)



Pressure rod with threaded flange with flat-face (3/4"-16 UNF-3A) and O-ring
 HL [length mm: XXXX] M
 HL [length in.: XXX.X] U

Pressure rod Ø: 12.7 mm (0.5 in.)
 Length: 100...7500 mm (4...295 in.)
 Operating pressure: 350 bar (5076 psi)
 Material flange:
 Stainless steel 1.4305 (AISI 303)
 Material rod:
 Stainless steel 1.4301 (AISI 304)



Profile with flange
 HFP [length mm: XXXXX] M
 HFP [length in.: XXXX.X] U

Length: Max. 20 000 mm (max. 787 in.)
 Ingress protection: IP30
 Material: Aluminum

4.13 Frequently ordered accessories for RDV design – Additional options available in our [Accessories Catalog](#) 551 444

Position magnets

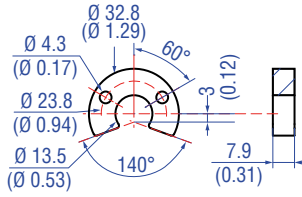
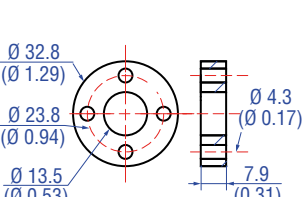
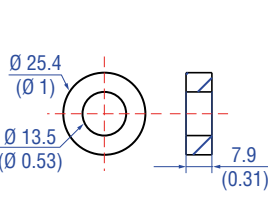
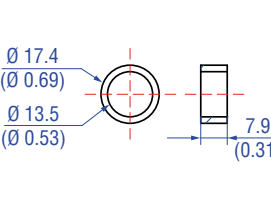
			
<p>U-magnet OD33 Part no. 251 416-2</p> <p>Material: PA ferrite GF20 Weight: Approx. 11 g Surface pressure: Max. 40 N/mm² Fastening torque for M4 screws: 1 Nm Operating temperature: -40...+105 °C (-40...+221 °F)</p> <p>Marked version for sensors with internal linearization: Part no. 254 226</p>	<p>Ring magnet OD33 Part no. 201 542-2</p> <p>Material: PA ferrite GF20 Weight: Approx. 14 g Surface pressure: Max. 40 N/mm² Fastening torque for M4 screws: 1 Nm Operating temperature: -40...+105 °C (-40...+221 °F)</p> <p>Marked version for sensors with internal linearization: Part no. 253 620</p>	<p>Ring magnet OD25.4 Part no. 400 533</p> <p>Material: PA ferrite Weight: Approx. 10 g Surface pressure: Max. 40 N/mm² Operating temperature: -40...+105 °C (-40...+221 °F)</p> <p>Marked version for sensors with internal linearization: Part no. 253 621</p>	<p>Ring magnet OD17.4 Part no. 401 032</p> <p>Material: PA neobond Weight: Approx. 5 g Surface pressure: Max. 20 N/mm² Operating temperature: -40...+105 °C (-40...+221 °F)</p>

Magnet spacer

O-rings

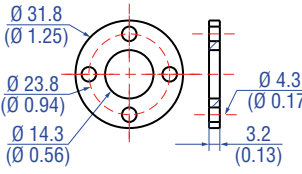
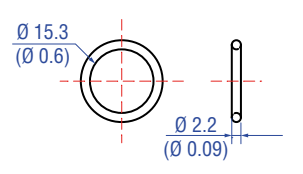
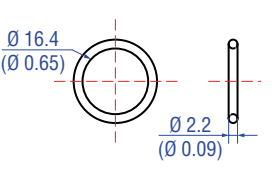
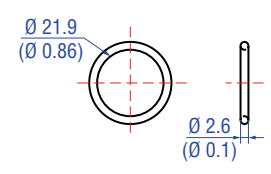
			
<p>Magnet spacer Part no. 400 633</p> <p>Material: Aluminum Weight: Approx. 5 g Surface pressure: Max. 20 N/mm² Fastening torque for M4 screws: 1 Nm</p>	<p>O-ring for threaded flange M18x1.5-6g Part no. 401 133</p> <p>Material: Fluoroelastomer Durometer: 75 ± 5 Shore A Operating temperature: -40...+204 °C (-40...+400 °F)</p>	<p>O-ring for threaded flange 3/4"-16 UNF-3A Part no. 560 315</p> <p>Material: Fluoroelastomer Durometer: 75 ± 5 Shore A Operating temperature: -40...+204 °C (-40...+400 °F)</p>	<p>O-ring for pressure fit flange Ø 26.9 mm Part no. 560 705</p> <p>Material: Nitrile rubber Operating temperature: -53...+107 °C (-65...+225 °F)</p>

O-rings

Mounting accessories

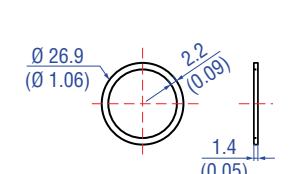
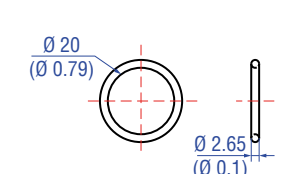
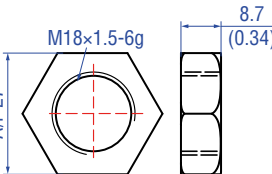
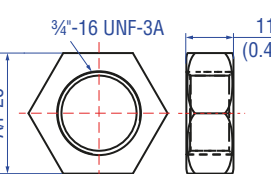
			
<p>Back-up ring for pressure fit flange Ø 26.9 mm Part no. 560 629</p> <p>Material: Polymyte Durometer: 90 Shore A</p>	<p>O-ring for mounting block with bottom entry Part no. 561 435</p> <p>Material: FKM Durometer: 80 ± 5 Shore A Operating temperature: -15...+200 °C (5...+392 °F)</p>	<p>Hex jam nut M18x1.5-6g Part no. 500 018</p> <p>Material: Steel, zinc plated</p>	<p>Hex jam nut 3/4"-16 UNF-3A Part no. 500 015</p> <p>Material: Steel, zinc plated</p>



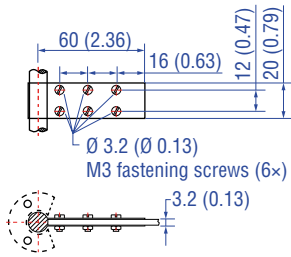

Mounting accessory





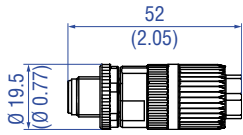
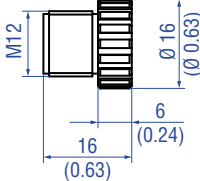
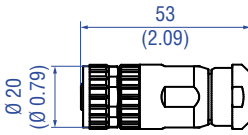
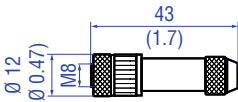
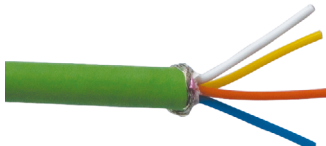

Fixing clip Part no. 561 481

Application: Used to secure sensor rods (Ø 10 mm (Ø 0.39 in.)) when using an U-magnet or block magnet
Material: Brass, non-magnetic

4.14 Frequently ordered accessories for PROFINET output – Additional options available in our [Accessories Catalog](#) 551 444

Cable connectors* – Signal		Cable connectors* – Power	
			
<p>M12 D-coded male connector (4 pin), straight Part no. 370 523</p> <p>Material: Zinc nickel-plated Termination: Insulation-displacement Cable Ø: 5.5...7.2 mm (0.2...0.28 in.) Wire: 24 AWG – 22 AWG Operating temperature: –25...+85 °C (–13...+185 °F) Ingress protection: IP65 / IP67 (correctly fitted) Fastening torque: 0.6 Nm</p>	<p>M12 connector end cap Part no. 370 537</p> <p>Female connectors M12 should be covered by this protective cap Material: Brass nickel-plated Ingress protection: IP67 (correctly fitted) Fastening torque: 0.39...0.49 Nm</p>	<p>M12 A-coded female connector (4 pin/5 pin), straight Part no. 370 677</p> <p>Material: GD-Zn, Ni Termination: Screw Contact insert: CuZn Cable Ø: 4...8 mm (0.16...0.31 in.) Wire: 1.5 mm² Operating temperature: –30...+85 °C (–22...+185 °F) Ingress protection: IP67 (correctly fitted) Fastening torque: 0.6 Nm</p>	<p>M8 female connector (4 pin), straight Part no. 370 504</p> <p>Material: CuZn nickel plated Termination: Solder Cable Ø: 3.5...5 mm (0.14...0.28 in.) Wire: 0.25 mm² Operating temperature: –40...+85 °C (–40...+185 °F) Ingress protection: IP67 (correctly fitted) Fastening torque: 0.5 Nm</p>
Cables		Cable sets	
			
<p>PUR signal cable Part no. 530 125</p> <p>Material: PUR jacket; green Features: Cat 5, highly flexible, halogen free, suitable for drag chains, mostly oil & flame resistant Cable Ø: 6.5 mm (0.26 in.) Cross section: 2 × 2 × 0.35 mm² (22 AWG) Bending radius: 5 × D (fixed installation) Operating temperature: –20...+60 °C (–4...+140 °F)</p>	<p>PVC power cable Part no. 530 108</p> <p>Material: PVC jacket; gray Features: Shielded, flexible, mostly flame resistant Cable Ø: 4.9 mm (0.19 in.) Cross section: 3 × 0.34 mm² Bending radius: 5 × D (fixed installation) Operating temperature: –30...+80 °C (–22...+176 °F)</p>	<p>Signal cable with M12 D-coded male connector (4 pin), straight – M12 D-coded, male connector (4 pin), straight Part no. 530 064</p> <p>Material: PUR jacket; green Features: Cat 5e Cable length: 5 m (16.4 ft) Cable Ø: 6.5 mm (0.26 in.) Ingress protection: IP65, IP67, IP68 (correctly fitted) Operating temperature: –30...+70 °C (–22...+158 °F)</p>	<p>Signal cable with M12 D-coded male connector (4 pin), straight – RJ45 male connector, straight Part no. 530 065</p> <p>Material: PUR jacket; green Features: Cat 5e Cable length: 5 m (16.4 ft) Cable Ø: 6.5 mm (0.26 in.) Ingress protection M12 connector: IP67 (correctly fitted) Ingress protection RJ45 connector: IP20 (correctly fitted) Operating temperature: –30...+70 °C (–22...+158 °F)</p>

* / Follow the manufacturer's mounting instructions
Controlling design dimensions are in millimeters and measurements in () are in inches
Color of connectors and cable jacket may change. Colors of the cores and technical properties remain unchanged.

Cable sets	Programming tools		
			
<p>Power cable with M8 female connector (4 pin), straight – pigtail Part no. 530 066 (5 m (16.4 ft.)) Part no. 530 096 (10 m (32.8 ft.)) Part no. 530 093 (15 m (49.2 ft.))</p>	<p>Power cable with M12 A-coded female connector (5 pin), straight – pigtail Part no. 370 673</p>	<p>TempoLink® kit for Tempsonics® R-Series V Part no. TL-1-0-EM08 (D56) Part no. TL-1-0-EM12 (D58)</p>	<p>TempoGate® smart assistant for Tempsonics® R-Series V Part no. TG-C-0-Dxx (xx indicates the number of R-Series V sensors that can be connected (even numbers only))</p>
<p>Material: PUR jacket; gray Features: Shielded Cable Ø: 5 mm (0.2 in.) Operating temperature: –40...+90 °C (–40...+194 °F)</p>	<p>Material: PUR jacket; black Features: Shielded Cable length: 5 m (16.4 ft) Ingress protection: IP67 (correctly fitted) Operating temperature: –25...+80 °C (–13...+176 °F)</p>	<ul style="list-style-type: none"> • Connect wirelessly via Wi-Fi enabled device or via USB with the diagnostic tool • Simple connectivity to the sensor via 24 VDC power line (permissible cable length: 30 m) • User friendly interface for mobile devices and desktop computers • See data sheet “TempoLink® smart assistant” (document part no.: 552070) for further information 	<ul style="list-style-type: none"> • OPC UA server for diagnostics of the R-Series V • For installation in the control cabinet • Connection via LAN and Wi-Fi • See data sheet “TempoGate® smart assistant” document part no.: 552110 for further information

Color of connectors and cable jacket may change. Colors of the cores and technical properties remain unchanged.

5. Operation

5.1 Initial start-up

The position sensor R-Series V PROFINET transfers position and velocity values via the PROFINET output.

PROFINET was developed by the PROFIBUS & PROFINET International (PI) organization and is a standard for transmissions in Industrial Ethernet. The sensor and the corresponding GSDML file (General Device Description) are certified by the PROFIBUS Nutzerorganisation e.V. (PNO).

The sensor can be ordered with different protocol options:

- Linear profile (U402/U412): The linear profile was developed by Temposonics for linear position sensors. With this profile, the position and the velocity of up to 30 position magnets can be measured and transferred simultaneously.
- Encoder profile (U401/U411): The encoder profile corresponds to the specification of the encoder profile V4.2 (PNO no. 3.162). With this profile, the position and the velocity of one position magnet can be measured and transferred simultaneously.

The R-Series V PROFINET supports both RT mode and IRT mode. With PROFINET RT (Real Time) the data exchange is without clock synchronization. In this case, the application, the data transmission and the field devices operate according to their own processing cycle. With PROFINET IRT (Isochronous Real Time) a clock-synchronous data transmission takes place. The application, the data transmission as well as the device cycle are synchronous. IRT enables a clock-synchronous data exchange with a minimum cycle time of 250 µs in the network.

NOTICE

Observe during commissioning

1. Before initial switch-on, check carefully if the sensor has been connected correctly.
2. Position the magnet in the measuring range of the sensor during first commissioning and after replacement of the magnet.
3. Ensure that the sensor control system cannot react in an uncontrolled way when switching on.
4. Ensure that the sensor is ready and in operation mode after switching on. The bus status LED is green.
5. Check the preset span start and end values of the measuring range (see chapter 4.6) and correct them via the customer's control system, if necessary.

5.2 LED status

A diagnostic display on the lid of the sensor informs about the current status of the sensor. The R-Series V is equipped with three LEDs:

- LED for status indication (condition indicator)
- LED for link activity of port 1 (port 1 L/A)
- LED for link activity of port 2 (port 2 L/A)

PROFINET RT & IRT LED status

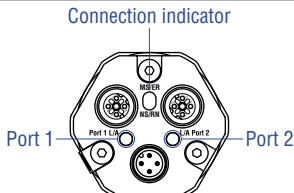

Connection indicator

Port 1 L/A Port 2 L/A

Device status LED

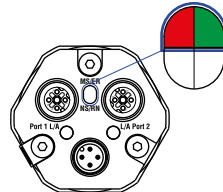

Green	Red	Information
● ON	○ OFF	No error
○ OFF	● ON	Operating voltage out of range or magnet error

Bus status LED

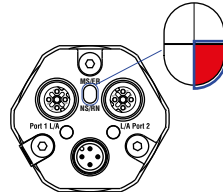

Red	Information
○ OFF	No error
● ON	No connection to controller
◐ Flashing	Parameterization error

LED for sensor identification

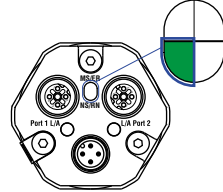

Green	Information
◐ Flashing	Sensor identification activated

Fig. 51: LED status, part 1

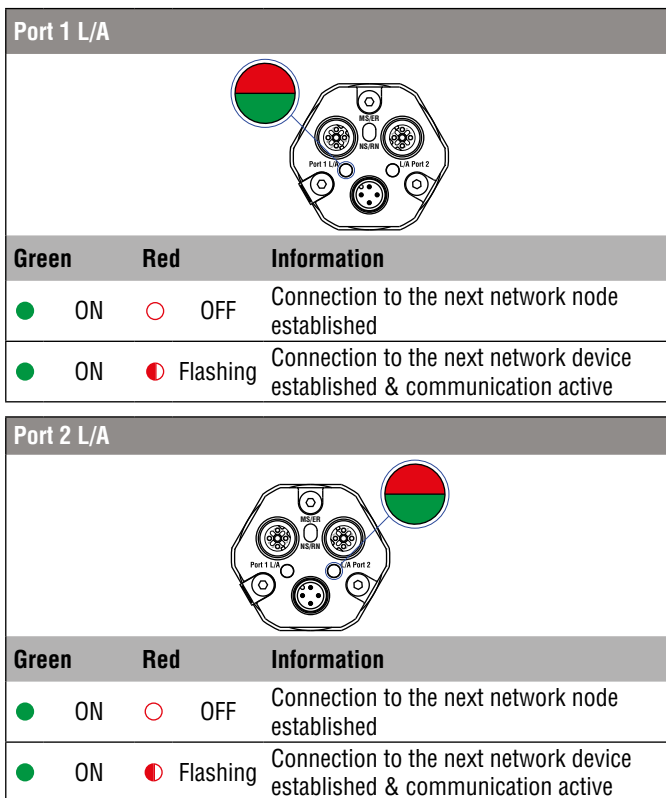

Fig. 52: LED status, part 2

5.3 Supported network functions

Following network functions are supported:

- RTC (Class 1 & Class 3) (Real Time Cyclic Protocol): Protocol for cyclic IO data (process data and measured values)
- RTA (Real Time Acyclic Protocol): Protocol for acyclic real time data (e.g. alarms)
- DCP (Discover and Basic Configuration Protocol): Assignment of IP configuration and device name
- DCE/RPC (Distributed Computing Environment Remote Procedure Call): Remote Procedure Calls via IP (e.g. parameter configuration)
- LLDP (Link Layer Discovery Protocol): Protocol used for neighborhood detection
- SNMP (Simple Network Management Protocol): Protocol used for network node diagnosis
- MRP (Media Redundancy Protocol): Searches for alternative routes in case of cable error or node error

Supported network topologies

PROFINET supports various topologies when building up a network. Thus, the usage of linear, star, ring and tree topologies are supported. For these topologies, switches are integrated in devices like the R-Series V PROFINET sensors. With integrated switches, a power failure will cause a communication interruption to the subsequent devices. This can be avoided, for example, by extending the line structure to a ring structure.

6. Programming and configuration in the TIA Portal

6.1 General Information

This instruction describes as an example the integration and programming of a Temposonics® R-Series V sensor with PROFINET into the TIA Portal (Totally Integrated Automation Portal) of Siemens AG. For controllers and software of other versions and manufacturers, the operation may differ.

NOTICE

Follow the information given in the controller operation manual.

Chapter 6.2 contains the integration and programming of the R-Series V PROFINET with linear profile (U402/U412). The implementation and configuration of the R-Series V with encoder profile (U401/U411) is described in chapter 6.3.

6.2 Parameter description for linear profile

After you have created a project, you can include the sensor via its GSDML file. The properties and functions of a PROFINET IO field device are described in a GSDML (General Station Description) file. The XML-based GSDML file contains all relevant data that is important for both the implementation of the device in the controller and the data exchange during operation.

The GSDML file for the R-Series V PROFINET is available on our homepage www.temposonics.com. The GSDML file of the R-Series V PROFINET is packed into a zip file containing the data for the linear profile and encoder profile. Download the GSDML file and save it on your computer. To include the GSDML file, select "Tools" from the menu bar of the TIA portal and click on "Manage device description file (GSD)". The "Manage device description files" window opens (Fig. 53). Enter the source path where the R-Series V PROFINET with linear profile GSDML file is stored. Specify the location and press the "Install" button to install the GSDML file. The default name of the R-Series V PROFINET sensor is "MTS-R-Series-PNIO-MIF". This name can be changed.

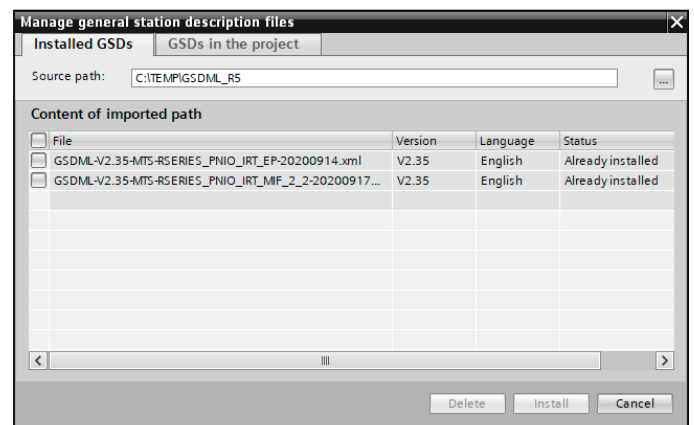

Fig. 53: The installed GSDML files

The R-Series V PROFINET supports both RT mode and IRT mode. The sensor is set to the respective mode during connection setup with the controller. By default, the sensor operates in RT mode. To operate the sensor in IRT mode, select the tab “General” in the section “Advanced options”. Select RT class “IRT” in the sub-section “Real time settings”. The IRT mode prioritizes the data packets (Fig. 54).

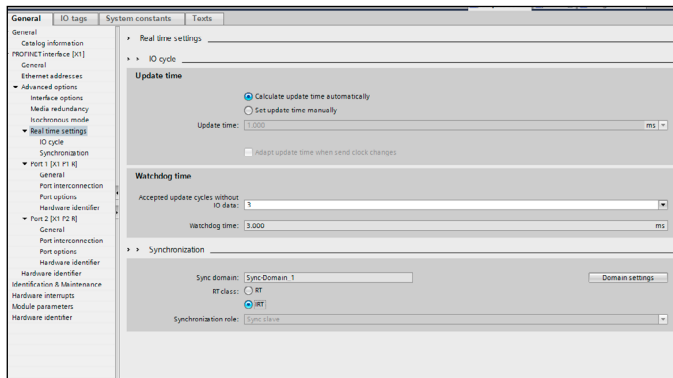

Fig. 54: Setting of the IRT mode

In order for the control unit to be able to access the sensor data isochronously, the isochronous mode in the “Advanced options” section of the “General” tab, has to be activated. This results in a synchronization to the transmission clock to the controller. By default, the isochronous mode is deactivated (Fig. 55).

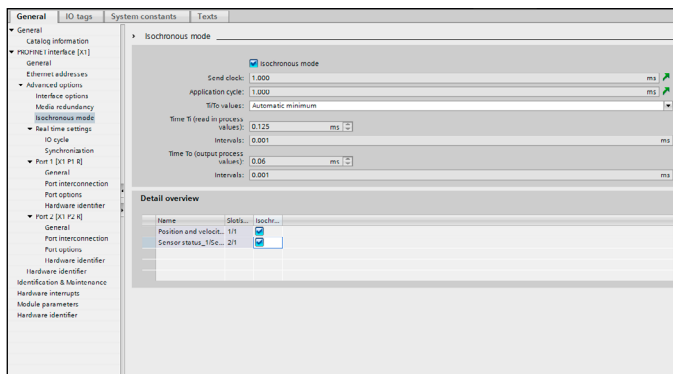

Fig. 55: Activation of isochronous control mode

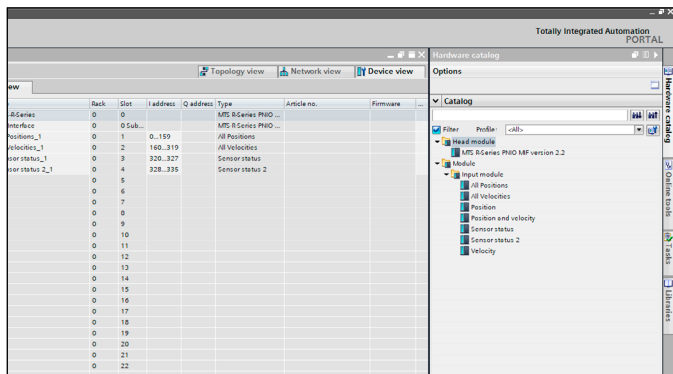

Fig. 56: Hardware catalog

Different input modules are available for the R-Series V PROFINET with linear profile. The following “Input modules” can be selected in the “Catalog” section:

- **All positions:** This module contains the positions of up to 30 magnets. The number of magnets shown in this module depends on the number of magnets specified in the parameter “Number of magnets”. With this module, 160 bytes are always transferred. Each magnet is assigned 4 bytes for the position value (1st magnet: 0...3 bytes, 2nd magnet: 4...7, etc.). If less than 30 magnets are operated on the sensor the unused bytes written with “0”.
- **All velocities:** This module contains the velocity of up to 30 magnets. The number of magnets shown in this module depends on the number of magnets specified in the parameter “Number of magnets”. With this module, 160 bytes are always transferred. Each magnet is assigned 4 bytes for the velocity value (1st magnet: 0...3 bytes, 2nd magnet: 4...7, etc.). If less than 30 magnets are operated on the sensor, the unused bytes are written with “0”.
- **Position:** This module contains the position of a magnet. Afterwards you must assign a magnet to this module.
- **Position and velocity:** This module contains the position and velocity of a magnet. This module transfers 8 bytes. The bytes 0...3 contain the position value and the bytes 4...7 contain the velocity value of the selected magnet. Afterwards you must assign a magnet to this module.
- **Sensor status:** This module shows the following values of the sensor:
 - Current power supply in mV
 - Number of magnets on the sensor rod
 - Bit mask for indicating which magnet number is detected on the sensor

Reading these status values is described on page 44.

- **Sensor status 2:** This module indicates when a high limit is exceeded or a low limit is not reached. The switching points mark the beginning and the end of a work area (Fig. 57). According to Fig. 58, the status of the switching points is displayed via bits 0 and 1 of this module. Reading these status values is described on page 44.

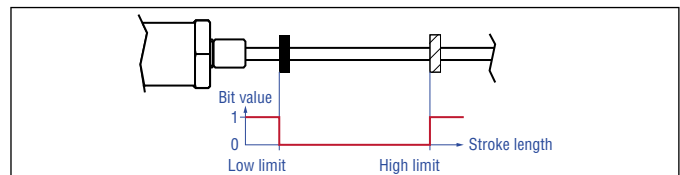

Fig. 57: Switching points for R-Series V PROFINET with linear profile

Bit	Description
Bit 0	Low limit <ul style="list-style-type: none"> • Bit value 0: Low limit not undershot • Bit value 1: Low limit undershot
Bit 1	High limit <ul style="list-style-type: none"> • Bit value 0: High limit not exceeded • Bit value 1: Low limit exceeded

Fig. 58: Reported values of the switching points at module “Sensor status 2”

- **Velocity:** This module contains the velocity of a magnet. Afterwards you must assign a magnet to this module.

Drag the selected module into the “Device Overview” window. While the “All positions” and “All velocities” modules contain up to 30 magnets, the “Position”, “Velocity” and “Position and velocity” modules contain the values of only one magnet at a time. Therefore, a magnet must be assigned to these modules. This assignment is carried out in the “Module parameters” section of the module. Select a magnet for the selected module under “Position parameters”. By default, all modules are assigned to magnet 1 (Fig. 59).

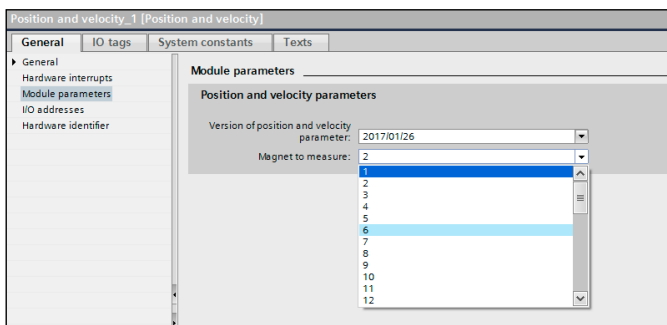

Fig. 59: Assignment of the magnets to the selected input modules

The parameters of the R-Series V PROFINET sensor are set in the sub-section “Module parameters” of the sensor. The following parameters can be adjusted in the “Sensor parameters” section (Fig. 63):

- **Resolution** (Setting of the resolution for position measurement)
Possible values: 0.5 µm; 1 µm; 2 µm; 5 µm; 10 µm; 50 µm or 100 µm
- **Filter Type** (Setting of the filter for the output value)
 - No filter (*default value*)
 - FIR (Finite Impulse Response Filter)
 - IIR (Infinite Impulse Response Filter)
- **Filter Window Size** (Setting of the number of position values for calculating the filter of the output value)
Possible values: 2...16
- **Velocity Window Size** (Setting of the number of position values for determining the velocity of the position magnet)
Possible values: 2...16
- **Velocity Output Unit** (Setting the unit of the velocity output)
Possible value: steps/1000 ms; steps/100 ms; steps/10 ms; mm/s
- **Measuring Direction** (Setting of the measuring direction for position or velocity measurement)
 - Forward (*default value*)
 - Reverse
- **Number of Magnets** (Setting of the number of position magnets that are used simultaneously on the sensor). If more magnets are configured than specified in the order code, a parameterization error is output. The alarm is output via alarm ID 16 (Fig. 62).

- **Wrong Number of Magnets** (Setting of the alarm behavior when the actual number of position magnets differs from the specified number of position magnets)
 - More or less than configured
 - More than configured
 - Less than configured
 - Magnet detection alarm off (*default value*)
The alarm is output via alarm ID 27 (Fig. 60).

Alarm ID decimal (hexadecimal)	Meaning
27 (1B)	Wrong number of magnets

Fig. 60: Alarm messages: Wrong number of magnets – linear profile

- **Power Supply Alarm** (Setting of the alarm behaviour when the power supply is out of the specified range).
 - Supply voltage too high or too low
 - Supply voltage too low
 - Supply voltage too high
 - Power supply alarm off (*default value*)
The alarm is output via alarm ID 17 (Fig. 61).

Alarm ID decimal (hexadecimal)	Meaning
17 (11)	Invalid operating voltage

Fig. 61: Alarm messages: Invalid operating voltage – linear profile

- **Extrapolation Mode** (Setting of the sensor behaviour in case of oversampling)
 - On (The minimum cycle time of the sensor when the Extrapolation Mode is on is 250 µs, independent of the number of magnets)
 - Off (*default value*)
- **Internal Linearization** (Setup of the internal linearization)
 - Enabled (Internal linearization can only be activated if the table of internal linearization is stored on the sensor.)
 - Disabled (*default value*)

If the internal linearization is to be activated although the corresponding table is not stored on the sensor, a parameterization error is reported (Fig. 62).

Alarm ID decimal (hexadecimal)	Meaning
16 (10)	Parameterization error

Fig. 62: Alarm messages: Parameterization error – linear profile

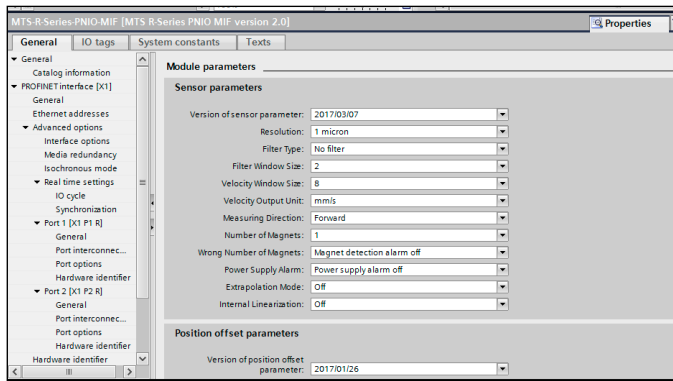

Fig. 63: Setting of the parameters

- **Offset:** In the subsection “Position offset parameters” you can set the offset, a shift of the measurement range start, separately for each magnet – independent of further magnets on the sensor rod/sensor profile (Fig. 64). You can set the values with a step size of 1 µm in the range between -214...+214 m.

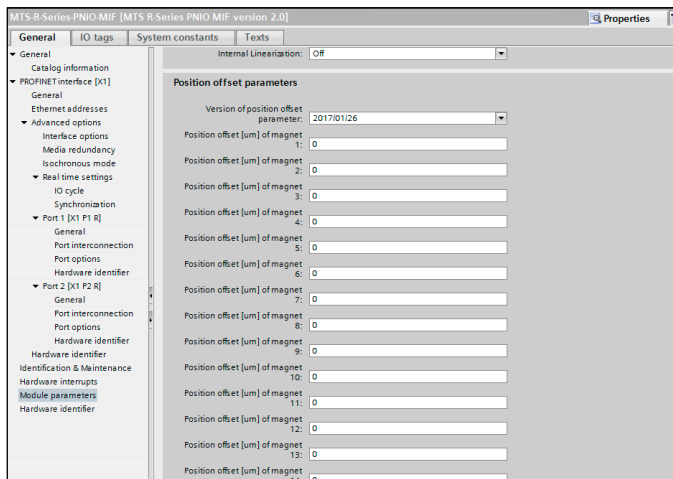

Fig. 64: Setting of the offset

- **Preset:** You can set a preset separately for each magnet – independently of other magnets on the sensor rod/sensor profile. To set the preset, move the magnet to the desired position. Then, edit the address API 0 Slot 0 Subslot 1 Index 0x2800. The 64 bit word for entering the preset is structured as follows (Fig. 65):
 - The first 24 bits represent the version identifier. Enter the word 0x00200414 at this point. This is to avoid an unintentional change of the preset.
 - The following 8 bits indicate the magnet for which the preset is to be changed. Enter the magnet number at this point.
 - The last 32 bits specify the value that is to be reported at this position in the future. Enter the desired value for this position.

24 bit	8 bit	32 bit
Version identifier	Magnet no.	Preset (future value at this position)

Fig. 65: Structure of 64 bit word for entering a preset at R-Series V PROFINET with linear profile

- **Reading the values of the input module “Sensor status”:** To read the information from the input module “Sensor status”, drag this module into the “Device Overview” window. The module “Sensor status” consists of 64 bits (Fig. 66):
 - The first 16 bit indicate the current power supply.
 - The following 8 bit indicate the number of magnets detected on the sensor rod/sensor profile.
 - The last 40 bits form the bit mask for displaying the detected magnets. For each magnet one bit with the following values is available:
 - Bit value 0: No magnet is detected for this magnet number
 - Bit value 1: A magnet is detected for this magnet number

16 bit	8 bit	40 bit
Power supply	Number of magnets	40 39 38 ... Magnet no. ... 3 2 1 Bit mask 1 bit per magnet

Fig. 66: Structure of the input module “Sensor status” at R-Series V PROFINET with linear profile

- **Setting the switching points for input module “Sensor status 2”:** To read the information from the input module “Sensor status 2”, drag this module into the “Device Overview” window. In the “Module parameters” section of the sensor, you can set the parameters for switching points under “Work area parameters” (Fig. 67):
 - Work area checking (setting for checking):
 - On (Activation of the checking of the swichting points)
 - Off (Deactivate the checking of the switching points) (default value)
 - Magnet to check for work area low limit (Select magnet for checking the low limit)
 - Magnet to check for work area high limit (Select magnet for checking the high limit)
 - Work area low limit (Position of the low limit in µm)
 - Work area high limit (Position of the high limit in µm)
 - Work area check hysteresis (Setting the hysteresis for the switching points in µm)

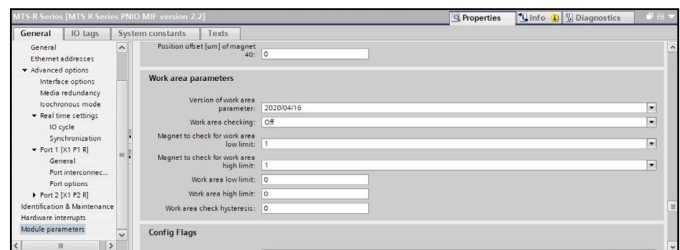

Fig. 67: Setting the switching points for the work area

The status of the switching points is reported in parallel to the position values or velocity values via the PROFINET protocol. A magnet must be specified for each switching point, which is used to check the respective limit. For a single position measurement with one magnet, the same magnet is assigned to the high and the low limit. For a multi-position measurement, you can assign different magnets on the sensor to the high and the low limit. Fig. 68 shows an example with three magnets. Magnet 1 is used to check the low limit, while the magnet 3 is used to monitor the high limit. Magnet 2 has no influence on the checking of the work area.

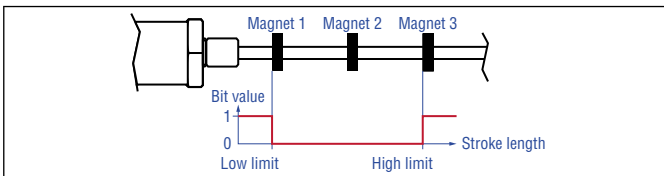

Fig. 68: Example of checking the switching points with R-Series V PROFINET with 3 magnets

- **Ignoring offsets configured in the project:** You can use the “Config Flags 1” entry to set whether the sensor should accept or ignore the offsets transmitted by the controller when establishing the connection. You can adjust this in the module parameters of the sensor in the “Config Flags” section (Fig. 69). You can set the following values for bit 1 of the “Config Flags 1” entry:
 - Value 0: The offsets configured in the project are accepted by the sensor
 - Value 1: The offsets configured in the project are ignored by the sensor

The other bits of “Config Flags 1” as well as the entries “Config Flags 2” and “Config Flags 3” have no influence on the linear profile.

Config Flags	
Version of config flags:	2020/01/09
Config Flags 1:	0
Config Flags 2:	0
Config Flags 3:	0

Fig. 69: Config Flags – linear profile

- **Reading additional information regarding the sensor status:** In parallel to the position values and the velocity values, the sensor can output further information on the sensor status via the PROFINET protocol. This information is stored in an array with 19 Integer32 values, which you call via the address API 0 Slot 0 Subslot 1 Index 2000.

Index	Subindex in array	Name	Object type	Attribute	Data type	Description
0x2000		Sensor status				
	0	Number of entries	Variable	ro	Integer32	
	1	Time since last update	Variable	ro	Integer32	Age of the status data in ms
	2	Status data version	Variable	ro	Integer32	Version number
	3	Operational time	Variable	ro	Integer32	Total operational time of the sensor
	4	Odometer	Variable	ro	Integer32	Total distance travelled by the position magnet in cm
	5	Magnet cycles	Variable	ro	Integer32	Total number of directional changes of the magnet
	6	Minimum input voltage	Variable	ro	Integer32	Minimum input voltage so far in mV
	7	Maximum input voltage	Variable	ro	Integer32	Maximum input voltage so far in mV
	8	Current input voltage	Variable	ro	Integer32	Current input voltage
	9	Minimum temperature	Variable	ro	Integer32	Minimum temperature inside the sensor electronics housing so far in °C
	10	Maximum temperature	Variable	ro	Integer32	Maximum temperature inside the sensor electronics housing so far in °C
	11	Current temperature	Variable	ro	Integer32	Current temperature inside the sensor electronics housing in °C
	12	Input voltage out of range	Variable	ro	Integer32	Duration of exceeding or falling below the permissible power supply range in ms
	13	Temperature out of range	Variable	ro	Integer32	Duration of exceeding or falling below the permissible operating temperature range in ms
	14	Reserved for future use	Variable	ro	Integer32	Reserved for future use
	15	Reserved for future use	Variable	ro	Integer32	Reserved for future use
	16	Reserved for future use	Variable	ro	Integer32	Reserved for future use
	17	Reserved for future use	Variable	ro	Integer32	Reserved for future use
	18	Reserved for future use	Variable	ro	Integer32	Reserved for future use

Fig. 70: Array with additional information regarding the sensor status

6.3 Parameter description for encoder profile V4.2

After you have created a project, you can include the sensor via its GSDML file. The properties and functions of a PROFINET IO field device are described in a GSDML (General Station Description) file. The XML-based GSDML file contains all relevant data that is important for both the implementation of the device in the controller and the data exchange during operation.

The GSDML file for the R-Series V PROFINET is available on our homepage www.temposonics.com. The GSDML file of the R-Series V PROFINET is packed into a zip file containing the data for the linear profile and encoder profile. Download the GSDML file and save it on your computer. To include the GSDML file, select “Tools” from the menu bar of the TIA portal and click on “Manage device description file (GSD)”. The “Manage device description files” window opens (Fig. 71). Enter the source path where the GSDML file of the R-Series V PROFINET with encoder profile is stored. Specify the location and press the “Install” button to install the GSDML file. The default name of the R-Series V PROFINET sensor is “MTS-R-Series-PNIO-EP”. This name can be changed.

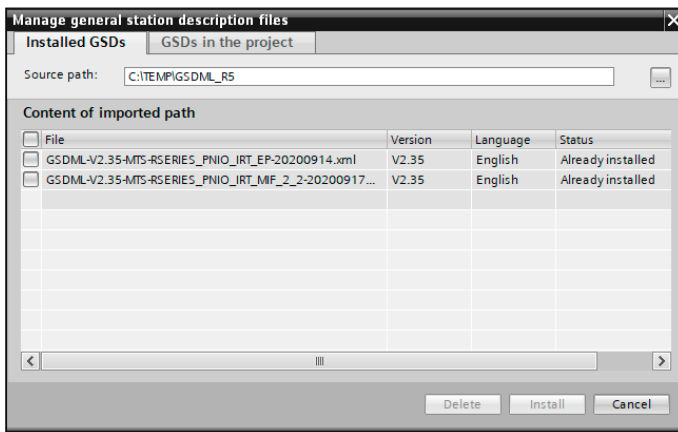

Fig. 71: View the installed GSDML files

The R-Series V PROFINET supports both RT mode and IRT mode. The sensor is set to the respective mode during connection setup with the controller. By default, the sensor operates in RT mode. To operate the sensor in IRT mode, select the tab “General” in the section “Advanced options”. Select RT class “IRT” in the sub-section “Real time settings”. The IRT mode prioritizes the data packets (Fig. 72).

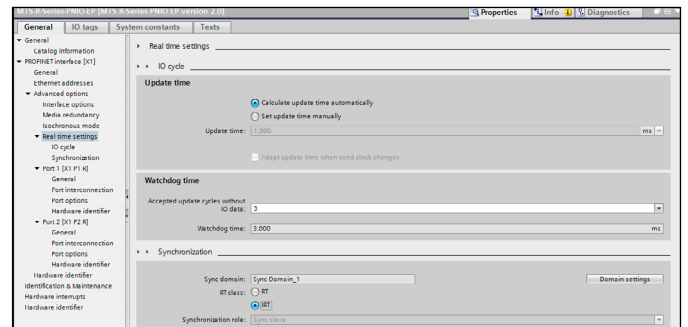

Fig. 72: Setting of the IRT mode

To enable the control to access the sensor data isochronously, the isochronous mode must be activated in the “Advanced options” section of the “General” tab. This results in a synchronization to the transmission clock to the controller. The isochronous mode is deactivated by default (Fig. 73).

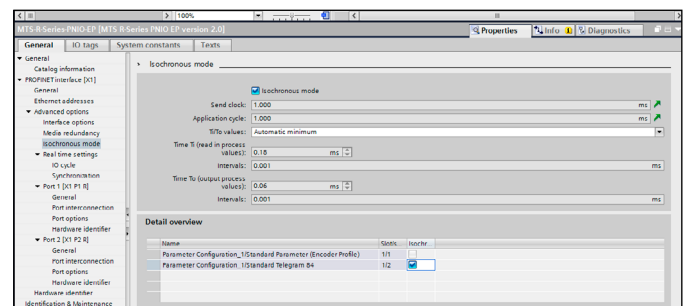

Fig. 73: Activation of the isochronous mode

Different telegrams are available for the sensor. The telegrams can be selected in the “Catalog” section. A detailed description of the telegrams is shown in Fig. 74 & Fig. 75.

Temposonics® R-Series V PROFINET IO RT & IRT
 Operation Manual

Standard telegram 81																									
Standard telegram 81 uses 4 bytes for output data from the IO controller to the sensor and 12 bytes of input data from the sensor to the IO controller.																									
Output data from the IO controller (control → sensor)																									
IO Data	1			2																					
Byte	0	1	2	3																					
Actual value	STW2_ENC			G1_STW																					
Description	Encoder control word 2			Sensor control word																					
Input data to the IO controller (sensor → control)																									
IO Data	1			2			3			4			5			6									
Byte	0	1	2	3	4	5	6	7	8	9	10	11													
Actual value	ZSW2_ENC			G1_ZSW			G1_XIST1			G1_XIST2															
Description	Status word 2			Status word			Position value			Position value 2															
Standard telegram 82																									
Standard telegram 82 uses 4 bytes for output data from the IO controller to the sensor and 14 bytes of input data from the sensor to the controller.																									
Output data from the IO controller (control → sensor)																									
IO Data	1			2																					
Byte	0	1	2	3																					
Actual value	STW2_ENC			G1_STW																					
Description	Encoder Control Word 2			Sensor Control Word																					
Input data to the IO controller (sensor → control)																									
IO Data	1			2			3			4			5			6		7							
Byte	0	1	2	3	4	5	6	7	8	9	10	11	12	13											
Actual value	ZSW2_ENC			G1_ZSW			G1_XIST1			G1_XIST2			NIST_A												
Description	Status word 2			Status word			Position value			Position value 2			Velocity												
Standard telegram 83																									
Standard telegram 83 uses 4 bytes for output data from the controller to the sensor and 16 bytes of input data from the sensor to the controller.																									
Output data from the IO controller (control → sensor)																									
IO Data	1			2																					
Byte	0	1	2	3																					
Actual value	STW2_ENC			G1_STW																					
Description	Encoder Control Word 2			Sensor Control Word																					
Input data to the IO controller (sensor → control)																									
IO Data	1			2			3			4			5			6		7		8					
Byte	0	1	2	3	4	5	6	7	8	9	10	11	12	13	14	15									
Actual value	ZSW2_ENC			G1_ZSW			G1_XIST1			G1_XIST2			NIST_B												
Description	Status word 2			Status word			Position value			Position value 2			Velocity												
Standard telegram 84																									
Standard telegram 84 uses 4 bytes for output data from the controller to the sensor and 20 bytes of input data from the sensor to the controller.																									
Output data from the IO controller (control → sensor)																									
IO Data	1			2																					
Byte	0	1	2	3																					
Actual value	STW2_ENC			G1_STW																					
Description	Encoder control word 2			Sensor control word																					
Input data to the IO controller (sensor → control)																									
IO Data	1			2			3			4			5			6		7		8		9		10	
Byte	0	1	2	3	4	5	6	7	8	9	10	11	12	13	14	15	16	17	18	19					
Actual value	ZSW2_ENC			G1_ZSW			G1_XIST3			G1_XIST2			NIST_B												
Description	Status word 2			Status word			Position value			Position value 2			Velocity												

Fig. 74: Source: PROFIBUS Nutzerorganisation e.V.; 2017; Encoder Profile Technical Specification for PROFIBUS and PROFINET related to PROFIdrive Version 4.2

Control word 2 (STW2_ENC)			
Bit	Value	Significance	Comments
0...6	–	–	Reserved
7	$\frac{1}{0}$	Fault acknowledge (0 → 1)	The fault signal is acknowledged with a positive edge; the sensor reaction to a fault depends on the type of fault.
8, 9	–	–	Reserved
10	1	Control by PLC	Control via interface, EO IO data is valid.
	0	No control by PLC	EO IO data not valid; except sign-of-life.
11	–	–	Reserved
12...15	–	Controller sign-of-life	Supported in IRT mode
Status word 2 (ZSW2_ENC)			
Bit	Value	Significance	Comments
0...2	–	–	Reserved
3	1	Fault present	Unacknowledged faults or currently not acknowledged faults (fault messages) are present (in the buffer). The fault reaction is fault-specific and device-specific. The acknowledging of a fault may only be successful, if the fault cause has disappeared or has been removed before. If the fault has been removed the sensor returns to operation. The related fault numbers are in the fault buffer.
	0	No fault	
4...8	–	–	Reserved
9	1	Control request	The automation system is requested to assume control.
	0	No control request	Control by automation system is not possible, only possible at the device or by another interface.
10, 11	–	–	Reserved
12...15	–	Encoder sign-of-life	Supported in IRT mode
Sensor status word (G1_ZSW)			
Bit	Function	Comments	
0...7	Reference mark search, measurement on the fly	–	
8	Probe 1 deflected	–	
9	Probe 2 deflected position mode (preset)	–	
10	Reserved, set to zero	–	
11	Requirements of error acknowledgment detected	–	
12	Set/shift of home position (preset) executed	–	
13	Transmit absolute value cyclically	If bit 13 transmits absolute value cyclically or bit 15 sensor error is not set there is no valid value or error code transferred in G1_XIST2.	
		Bit 13 transmits absolute value cyclically cannot be set at the same time as bit 15 sensor error. These bits are used to indicate either a valid position value transmission (bit 13) or the error code transmission (bit 15) in G1_XIST2.	
14	Parking sensor active	–	
15	Sensor error	–	
Sensor control word (G1_STW)			
Bit	Function	Comments	
0...7	Reference mark search, measurement on the fly		
8...10	Reserved (without effect)		
11	Home position mode position mode (preset)		
12	Request set/shift of home position (preset)		
13	Request absolute value cyclically		
14	Activate parking sensor	If the sensor parking is activated (bit 14 = 1) the sensor is still on the bus with the slave sign-of-life active and the sensor error and diagnostics switched off.	
15	Acknowledging a sensor error		

Fig. 75: Source: PROFIBUS Nutzerorganisation e.V.; 2017; Encoder Profile Technical Specification for PROFIBUS and PROFINET related to PROFIdrive Version 4.2

The selected telegram must be dragged into the “Device Overview” window. In the example shown, telegram 84 was selected and assigned to slot 1 subslot 2 (Fig. 76).

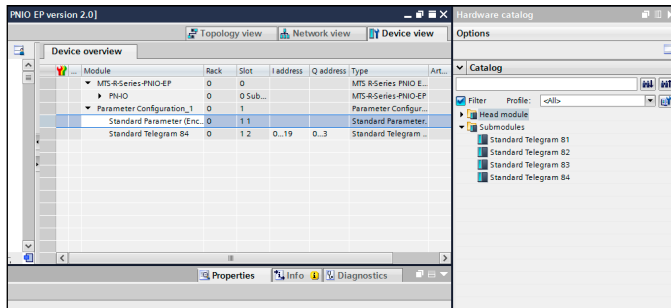

Fig. 76: Hardware catalog

To configure the parameters, select the entry “Standard Parameters (Encoder Profile)” in the “Device Overview” window. The parameters of the R-Series V sensor can be set in the sub-section “Module Parameters” of the “General” tab (Fig. 77).

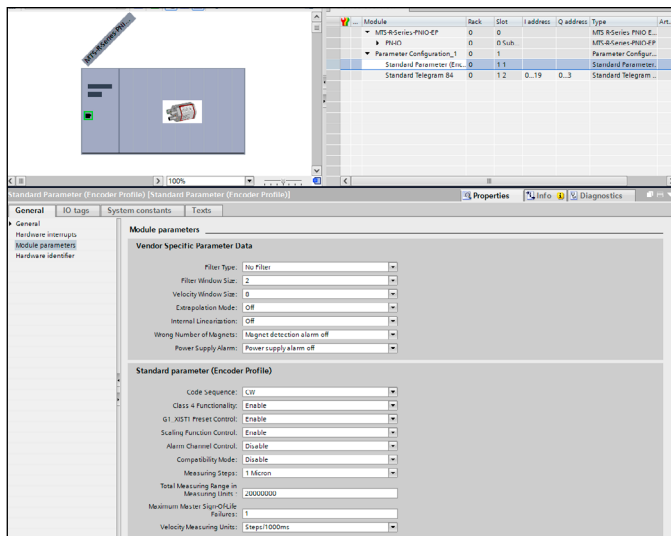

Fig. 77: Setting of the parameters

Vendor Specific Parameter Data:

- **Filter Type** (Setting of the filter for the output value)
 - No filter (*default value*)
 - FIR (finite impulse response filter)
 - IIR (infinite impulse response filter)
- **Filter Window Size** (Setting of the number of position values for calculating the filter of the output value)
Possible values: 2...16 (*default value* = 2)
- **Velocity Window Size** (Setting of the number of position values for determining the velocity of the position magnet)
Possible values: 2...16 (*default value* = 8)

- **Extrapolation Mode** (Setting of the sensor behaviour in case of oversampling)

- On (The minimum cycle time of the sensor when the Extrapolation Mode is on is 250 µs)
- Off (*default value*)

- **Internal Linearization** (Setting of the internal linearization)
 - On (Internal linearization can only be activated if the table of internal linearization is stored on the sensor)
 - Off (*default value*)

If the internal linearization is to be activated although the corresponding table is not stored on the sensor, a parameterization error is reported (Fig. 78)

- **Wrong Number of Magnets** (Setting of the alarm behaviour when the actual number of position magnets differs from the specified number of position magnets)
 - More or less than one magnet
 - More than one magnet
 - Less than one magnet
 - Magnet detection alarm off (*default value*)
- **Power Supply Alarm** (Setting of the alarm behaviour when the power supply is out of the specified range)
 - Supply voltage too high or too low
 - Supply voltage too low
 - Supply voltage too high
 - Power supply alarm off (*default value*)

These diagnostic outputs are implemented via alarm messages and the PROFINET interface. The R-Series V PROFINET sensors support the following diagnostic messages:

Alarm ID		Meaning
decimal	hexadecimal	
37137	9111	High operating voltage
37136	9110	Low operating voltage
37120	9100	Wrong number of magnets
16	10	Parametrization error

Fig. 78: Alarm messages – Encoder Profile V4.2

- **Accepting negative preset values:** You can use the “Config Flags 1” entry to set that negative preset values are also accepted in addition to positive preset values. You can adjust this in the module parameters of the module “Standard Parameters” in the “Config Flags” section (Fig. 79). You can set the following values for bit 2 of the “Config Flags 1” entry:
 - Value 0: Only positive preset values are accepted. Negative preset values are not accepted.
 - Value 1: Positive and negative preset values are accepted
 The other bits of “Config Flags 1” as well as the entry “Config Flags 3” have no influence on the encoder profile.

- **Setting the parameter P65005:** You can use the “Config Flags 1” entry to set how to change the parameter P65005. You can adjust this in the module parameters of the module “Standard Parameters” in the “Config Flag” section (Fig. 79). You can set the following values for bit 3 of the “Config Flags 1” entry:
 - Value 0: Parameter P65005 is not overwritten by the parameter set.
 - Value 1: Parameter P65005 is set to the value of “Config Flag 2”. Enter the value for parameter P65005 in “Config Flag 2”. For further information about parameter P65005 see document “Profile Drive Technology Encoder Profile (Version 4.2)” by the PROFIBUS Nutzerorganisation e.V..

The screenshot shows a configuration window with the following fields:

- Wrong Number of Magnets: More or less magnets than configured
- Power Supply Alarm: Supply voltage too high or too low
- Config Flags section:
 - Version of config flags: 2020/01/09
 - Config Flags 1: 0
 - Config Flags 2: 0
 - Config Flags 3: 0

Fig. 79: Config Flags – Encoder profile

- **Reading additional information regarding the sensor status:** In parallel to the position values and the velocity values, the sensor can output further information on the sensor status via the PROFINET protocol. This information is stored in an array with 19 Integer32 values, which you call via the address API 0x3d00 Slot 1 Subslot 1 Index 2000.

Index	Subindex in array	Name	Object type	Attribute	Data type	Description
0x2000		Sensor status				
	0	Number of entries	Variable	ro	Integer32	
	1	Time since last update	Variable	ro	Integer32	Age of the status data in ms
	2	Status data version	Variable	ro	Integer32	Version number
	3	Operational time	Variable	ro	Integer32	Total operational time of the sensor
	4	Odometer	Variable	ro	Integer32	Total distance travelled by the position magnet in cm
	5	Magnet cycles	Variable	ro	Integer32	Total number of directional changes of the magnet
	6	Minimum input voltage	Variable	ro	Integer32	Minimum input voltage so far in mV
	7	Maximum input voltage	Variable	ro	Integer32	Maximum input voltage so far in mV
	8	Current input voltage	Variable	ro	Integer32	Current input voltage
	9	Minimum temperature	Variable	ro	Integer32	Minimum temperature inside the sensor electronics housing so far in °C
	10	Maximum temperature	Variable	ro	Integer32	Maximum temperature inside the sensor electronics housing so far in °C
	11	Current temperature	Variable	ro	Integer32	Current temperature inside the sensor electronics housing in °C
	12	Input voltage out of range	Variable	ro	Integer32	Duration of exceeding or falling below the permissible power supply range in ms
	13	Temperature out of range	Variable	ro	Integer32	Duration of exceeding or falling below the permissible operating temperature range in ms
	14	Reserved for future use	Variable	ro	Integer32	Reserved for future use
	15	Reserved for future use	Variable	ro	Integer32	Reserved for future use
	16	Reserved for future use	Variable	ro	Integer32	Reserved for future use
	17	Reserved for future use	Variable	ro	Integer32	Reserved for future use
	18	Reserved for future use	Variable	ro	Integer32	Reserved for future use

Fig. 80: Array with additional information regarding the sensor status

In addition to the manufacturer-specific parameters, there are the following standard parameters according to the encoder profile:

• **Code sequence:**

- Specifies the measurement direction for position measurement
 - CW (clockwise) = forward (values increasing from sensor electronics housing to rod end/profile end) (*default value*)
 - CCW (counter clockwise) = reverse (values decreasing from sensor electronics housing to rod end/profile end)

• **Class 4 functionality:**

Activating/deactivating the following parameters: Code sequence, scaling function, measuring step, total measuring range, velocity unit and G1_XIST1 preset control. With “Class 4 functionality” de-activated, the sensor measures with a resolution of 1 µm. Any configured “Preset” is not taken into account and the measuring direction is forward. If the parameter “G1_XIST1 preset control” is activated this will affect G1_XIST1, G1_XIST2 and G1_XIST3.

• **G1_XIST1 preset control (preset affects XIST1):**

Specifies the effect of a preset on G1_XIST1. This parameter is without function if the parameter Class 4 functionality is deactivated. If Class 4 functionality is activated and G1_XIST1 preset control is disabled, the position value in G1_XIST1 will not be affected by a preset. Should be selected, if the preset should have an impact not only on G1_XIST2 and G1_XIST3, but also on G1_XIST1.

• **Scaling function control:**

Activating/deactivating the scaling function. The “Scaling function”- parameter can be used to change the encoder resolution. Note that the “Scaling function” parameters can be activated only, if “Class 4 functionality” and “Scaling function control” are activated. Otherwise, the scaling function is disabled and the resolution is 1 µm.

• **Alarm channel control:**

Activating/deactivating the alarm channel. This parameter is used to limit the amount of data sent. This parameter is only supported in compatibility mode and can be deactivated only in compatibility mode V3.1.

• **Compatibility mode V3.1:**

Activating/deactivating the compatibility mode. This parameter indicates, if the sensor should run in a mode compatible with encoder profile V3.1. The functions which are affected when this parameter is activated are listed in Fig. 83.

• **Measurement step:**

Position measurement resolution 0.5, 1, 2, 5, 10, 50, 100 µm, provided that the “Scaling function” is activated.

• **Measurement range:**

Limits the measuring range to the number of measurement steps, provided that the “Scaling function” is activated.

• **Maximum master sign-of-life failures:**

Specifies the number of allowed failures of the masters sign-of-life. This parameter is only supported in compatibility mode V3.1. If the maximum number of permissible errors is exceeded, the position sensor sends a sign of life error in G1_XIST2.

• **Velocity unit ³:**

Specifies the coding of the velocity units used to configure the signals NIST_A and NIST_B (Fig. 81).

Velocity measuring units	Value
Steps/s	0
Steps/100 ms	1
Steps/10 ms	2

Fig. 81: Velocity measuring units

Attribute	Meaning	Value
Enable	Compatibility with encoder profile V3.1	0
Disable	No backward compatibility (default)	1

Fig. 82: Compatibility mode

Function	Compatibility mode enabled (= 0)	Compatibility mode disabled (= 1)
Control by PLC (STW2_ENC)	Ignored, the control word (G1_STW) and the set point values are always valid. Control requested (ZSW2_ENC) is not supported and is set to 0.	Supported
User parameter alarm channel control	Supported	Not supported, the application alarm channel is active and controlled by a PROFIdrive parameter.
P965 Profile Version	31 (V3.1)	42 (V4.2)

Fig. 83: Function

For more information about the standard parameters and functions according to the encoder profile V4.2 please refer to the document “Profile Drive Technology Encoder Profile (Version 4.2)” from PROFIBUS Nutzerorganisation e.V..

The operation manual and the GSD file for the R-Series V PROFINET with encoder profile 4.1 (PROFINET firmware < 2.2) can be found at www.temposonics.com under “Legacy Products”.

3/ A “step” corresponds to the selected resolution

7. TempoLink® smart assistant with R-Series V PROFINET

The TempoLink® smart assistant supports the R-Series V PROFINET. The TempoLink® smart assistant can be used to read current status information of the sensor and to adjust settings for identification of the sensor in the network. In addition, the current parameter settings can be viewed via the TempoLink® smart assistant. This allows the sensor to be checked offline, i.e. without integration into a network. For further information see the TempoLink® smart assistant operation manual (document part number: [551986](#)).

8. Maintenance and troubleshooting

8.1 Error conditions, troubleshooting

See chapter “5. Operation” on page 40.

8.2 Maintenance

The sensor is maintenance-free.

8.3 Repair

Repairs of the sensor may be performed only by Temposonics or a repair facility explicitly authorized by Temposonics. For return see chapter “2.6 Return” on page 4.

8.4 List of spare parts

No spare parts are available for this sensor.

8.5 Transport and storage

The conditions of transport and storage of the sensor match the operating conditions mentioned in this document.

9. Removal from service/dismantling

The product contains electronic components and must be disposed of in accordance with the local regulations.

10. Technical data

10.1 Technical data Temposonics® RP5

Output							
Interface	PROFINET RT PROFINET IRT version 2.3						
Data protocol	Linear profile and encoder profile V4.2						
Data transmission rate	100 MBit/s (maximum)						
Measured value	Position, velocity/option: Simultaneous multi-position and multi-velocity measurements up to 30 magnets						
Measurement parameters							
Resolution: Position	0.5...100 µm (selectable)						
Cycle time	Stroke length	≤ 50 mm	≤ 715 mm	≤ 2000 mm	≤ 4675 mm	≤ 6350 mm	
	Cycle time	250 µs	500 µs	1000 µs	2000 µs	4000 µs	
Linearity deviation ⁴	Stroke length	≤ 500 mm	> 500 mm				
	Linearity deviation	≤ ±50 µm	< 0.01 % F.S.				
Optional internal linearization: Linearity tolerance (applies for the first magnet for multi-position measurement)							
	Stroke length	25...300 mm	300...600 mm	600...1200 mm	1200...3000 mm	3000...5000 mm	5000...6350 mm
	typical	± 15 µm	± 20 µm	± 25 µm	± 45 µm	± 85 µm	± 95 µm
	maximum	± 25 µm	± 30 µm	± 50 µm	± 90 µm	± 150 µm	± 190 µm
Repeatability	< ±0.001 % F.S. (minimum ±2.5 µm) typical						
Hysteresis	< 4 µm typical						
Temperature coefficient	< 15 ppm/K typical						
Operating conditions							
Operating temperature	-40...+85 °C (-40...+185 °F)						
Humidity	90 % relative humidity, no condensation						
Ingress protection	IP67 (connectors correctly fitted)						
Shock test	150 g/11 ms, IEC standard 60068-2-27						
Vibration test	30 g/10...2000 Hz, IEC standard 60068-2-6 (excluding resonant frequencies)						
EMC test	Electromagnetic emission according to EN 61000-6-3						
	Electromagnetic immunity according to EN 61000-6-2						
	The RP5 sensors fulfill the requirements of the EMC directives 2014/30/EU, UKSI 2016 No. 1091 and TR CU 020/2011						
Magnet movement velocity	Magnet slider: Max. 10 m/s; U-magnet: Any; block magnet: Any						
Design/Material							
Sensor electronics housing	Aluminum (painted), zinc die cast						
Sensor profile	Aluminum						
RoHS compliance	The used materials are compliant with the requirements of EU Directive 2011/65/EU and EU Regulation 2015/863 as well as UKSI 2022 No. 622						
Stroke length	25...6350 mm (1...250 in.)						
Mechanical mounting							
Mounting position	Any						
Mounting instruction	Please consult the technical drawings on page 11						

Technical data "Electrical connection" on [page 55](#)

4/ With position magnet # 252 182

Electrical connection	
Connection type	2 × M12 female connectors (5 pin), 1 × M12 male connector (4 pin) or 2 × M12 female connectors (5 pin), 1 × M8 male connector (4 pin)
Operating voltage	+12...30 VDC ±20 % (9.6...36 VDC)
Power consumption	Less than 4 W typical
Dielectric strength	500 VDC (DC ground to machine ground)
Polarity protection	Up to -36 VDC
Overvoltage protection	Up to 36 VDC

10.2 Technical data Temposonics® RH5

Output						
Interface	PROFINET RT PROFINET IRT version 2.3					
Data protocol	Linear profile and encoder profile V4.2					
Data transmission rate	100 MBit/s (maximum)					
Measured value	Position, velocity/option: Simultaneous multi-position and multi-velocity measurements up to 30 magnets					
Measurement parameters						
Resolution: Position	0.5...100 µm (selectable)					
Cycle time	Stroke length	≤ 50 mm	≤ 715 mm	≤ 2000 mm	≤ 4675 mm	≤ 7620 mm
	Cycle time	250 µs	500 µs	1000 µs	2000 µs	4000 µs
Linearity deviation ⁵	Stroke length	≤ 500 mm	> 500 mm			
	Linearity deviation	≤ ±50 µm	< 0.01 % F.S.			
	Optional internal linearization: Linearity tolerance (applies for the first magnet for multi-position measurement)					
	Stroke length	25...300 mm	300...600 mm	600...1200 mm		
	typical	± 15 µm	± 20 µm	± 25 µm		
	maximum	± 25 µm	± 30 µm	± 50 µm		
Repeatability	< ±0.001 % F.S. (minimum ±2.5 µm) typical					
Hysteresis	< 4 µm typical					
Temperature coefficient	< 15 ppm/K typical					
Operating conditions						
Operating temperature	-40...+85 °C (-40...+185 °F)					
Humidity	90 % relative humidity, no condensation					
Ingress protection	IP67 (connectors correctly fitted)					
Shock test	150 g/11 ms, IEC standard 60068-2-27					
Vibration test	30 g/10...2000 Hz, IEC 60068-2-6 (excluding resonant frequencies) / RH5-J: 15 g/10...2000 Hz, IEC standard 60068-2-6 (excluding resonant frequencies)					
EMC test	Electromagnetic emission according to EN 61000-6-3					
	Electromagnetic immunity according to EN 61000-6-2 The RH5 sensors fulfill the requirements of the EMC directives 2014/30/EU, UKSI 2016 No. 1091 and TR CU 020/2011					
Operating pressure	350 bar (5,076 psi)/700 bar (10,153 psi) peak (at 10 × 1 min) for sensor rod/RH5-J: 800 bar (11,603 psi)					
Magnet movement velocity	Any					
Design/Material						
Sensor electronics housing	Aluminum (painted), zinc die cast					
Sensor flange	Stainless steel 1.4305 (AISI 303)					
Sensor rod	Stainless steel 1.4306 (AISI 304L)/RH5-J: Stainless steel 1.4301 (AISI 304)					
RoHS compliance	The used materials are compliant with the requirements of EU Directive 2011/65/EU and EU Regulation 2015/863 as well as UKSI 2022 No. 622					
Stroke length	25...7620 mm (1...300 in.)/RH5-J: 25...5900 mm (1...232 in.)					
Mechanical mounting						
Mounting position	Any					
Mounting instruction	Please consult the technical drawings on page 12 and page 13					

Technical data "Electrical connection" on [page 57](#)

5/ With position magnet # 251 416-2

Electrical connection	
Connection type	2 × M12 female connectors (5 pin), 1 × M12 male connector (4 pin) or 2 × M12 female connectors (5 pin), 1 × M8 male connector (4 pin)
Operating voltage	+12...30 VDC ±20 % (9.6...36 VDC)
Power consumption	Less than 4 W typical
Dielectric strength	500 VDC (DC ground to machine ground)
Polarity protection	Up to -36 VDC
Overvoltage protection	Up to 36 VDC

10.3 Technical data Temposonics® RFV

Output						
Interface	PROFINET RT PROFINET IRT version 2.3					
Data protocol	Linear profile and encoder profile V4.2					
Data transmission rate	100 MBit/s (maximum)					
Measured value	Position, velocity/option: Simultaneous multi-position and multi-velocity measurements up to 30 magnets					
Measurement parameters						
Resolution: Position	0.5...100 µm (selectable)					
Cycle time	Stroke length	≤ 715 mm	≤ 2000 mm	≤ 4675 mm	≤ 10,000 mm	≤ 20,000 mm
	Cycle time	500 µs	1000 µs	2000 µs	4000 µs	8000 µs
Linearity deviation ⁶	< ±0.02 % F.S. (minimum ±100 µm)					
Repeatability	< ±0.001 % F.S. (minimum ±2.5 µm) typical					
Hysteresis	< 4 µm typical					
Temperature coefficient	< 15 ppm/K typical					
Operating conditions						
Operating temperature	-40...+85 °C (-40...+185 °F)					
Humidity	90 % relative humidity, no condensation					
Ingress protection	IP30 (IP65 rating only for professional mounted guide pipe and if mating connectors are correctly fitted)					
Shock test	100 g/6 ms, IEC standard 60068-2-27					
Vibration test	5 g/10...2000 Hz, IEC standard 60068-2-6 (excluding resonant frequencies)					
EMC test	Electromagnetic emission according to EN 61000-6-3					
	Electromagnetic immunity according to EN 61000-6-2 The RFV sensors fulfill the requirements of the EMC directives 2014/30/EU, UKSI 2016 No. 1091 and TR CU 020/2011 under the condition of an EMC compliant installation ⁷					
Magnet movement velocity	Any					
Design/Material						
Sensor electronics housing	Aluminum (painted), zinc die cast					
Sensor flange	Stainless steel 1.4305 (AISI 303)					
Sensor rod	Stainless steel conduct with PTFE coating					
RoHS compliance	The used materials are compliant with the requirements of EU Directive 2011/65/EU and EU Regulation 2015/863 as well as UKSI 2022 No. 622					
Stroke length	150...20,000 mm (6...787 in.)					
Mechanical mounting						
Mounting position	Any					
Mounting instruction	Please consult the technical drawings on page 15					
Electrical connection						
Connection type	2 × M12 female connectors (5 pin), 1 × M12 male connector (4 pin) or 2 × M12 female connectors (5 pin), 1 × M8 male connector (4 pin)					
Operating voltage	+12...30 VDC ±20 % (9.6...36 VDC)					
Power consumption	Less than 4 W typical					
Dielectric strength	500 VDC (DC ground to machine ground)					
Polarity protection	Up to -36 VDC					
Overvoltage protection	Up to 36 VDC					

^{6/} With position magnet # 251 416-2

^{7/} The flexible sensor element must be mounted in an appropriately shielded environment

10.4 Technical data Temposonics® RDV

Output					
Interface	PROFINET RT PROFINET IRT version 2.3				
Data protocol	Linear profile and encoder profile V4.2				
Data transmission rate	100 MBit/s (maximum)				
Measured value	Position, velocity/option: Simultaneous multi-position and multi-velocity measurements up to 30 magnets				
Measurement parameters					
Resolution: Position	0.5...100 µm (selectable)				
Cycle time	Stroke length	≤ 715 mm	≤ 2000 mm	≤ 4675 mm	≤ 5080 mm
	Cycle time	500 µs	1000 µs	2000 µs	4000 µs
Linearity deviation ^{8, 9}	Stroke length	≤ 500 mm	> 500 mm		
	Linearity deviation	≤ ±50 µm	< 0.01 % F.S.		
	Optional internal linearization: Linearity tolerance (applies for the first magnet for multi-position measurement)				
	Stroke length	25...300 mm	300...600 mm	600...1200 mm	
	typical	±15 µm	±20 µm	±25 µm	
	maximum	±25 µm	±30 µm	±50 µm	
Repeatability	< ±0.001 % F.S. (minimum ±2.5 µm) typical				
Hysteresis	< 4 µm typical				
Temperature coefficient	< 15 ppm/K typical				
Operating conditions					
Operating temperature	-40...+85 °C (-40...+185 °F)				
Humidity	90 % relative humidity, no condensation				
Ingress protection	Sensor electronics IP67 (with professional mounted housing and connectors) Measuring rod with connecting cable for side cable entry IP65 Measuring rod with single wires and flat connector with bottom cable entry IP30				
Shock test	100 g/11 ms, IEC standard 60068-2-27				
Vibration test	10 g/10...2000 Hz, IEC standard 60068-2-6 (excluding resonant frequencies)				
EMC test	Electromagnetic emission according to EN 61000-6-3				
	Electromagnetic immunity according to EN 61000-6-2 The RDV sensors fulfill the requirements of the EMC directives 2014/30/EU, UKSI 2016 No. 1091 and TR CU 020/2011 under the condition of an EMC compliant installation ¹⁰				
Operating pressure	350 bar (5076 psi)/700 bar (10,153 psi) peak (at 10 × 1 min) for sensor rod				
Magnet movement velocity	Any				
Design/Material					
Sensor electronics housing	Aluminum (painted), zinc die cast				
Sensor rod with flange	Stainless steel 1.4301 (AISI 304)				
RoHS compliance	The used materials are compliant with the requirements of EU Directive 2011/65/EU and EU Regulation 2015/863 as well as UKSI 2022 No. 622				
Stroke length	25...2540 mm (1...100 in.) for pressure-fit flange »S«				
	25...5080 mm (1...200 in.) for all threaded flanges				
Mechanical mounting					
Mounting position	Any				
Mounting instruction	Please consult the technical drawings on page 18 and page 19				

Technical data "Electrical connection" on [page 60](#)

^{8/} With position magnet # 251 416-2

^{9/} For rod style »S« the linearity deviation can be higher in the first 30 mm (1.2 in.) of stroke length

^{10/} The cable between the sensor element and the sensor electronics housing must be mounted in an appropriately shielded environment

Temposonics® R-Series V PROFINET IO RT & IRT

Operation Manual

Electrical connection	
Connection type	2 × M12 female connectors (5 pin), 1 × M12 male connector (4 pin) or 2 × M12 female connectors (5 pin), 1 × M8 male connector (4 pin)
Operating voltage	+12...30 VDC ±20 % (9.6...36 VDC)
Power consumption	Less than 4 W typical
Dielectric strength	500 VDC (DC ground to machine ground)
Polarity protection	Up to -36 VDC
Overvoltage protection	Up to 36 VDC

11. Appendix I

Safety declaration

Dear Customer,

If you return one or several sensors for checking or repair, we need you to sign a safety declaration. The purpose of this declaration is to ensure that the returned items do not contain residues of harmful substances and/or that people handling these items will not be in danger.

Temposonics order number: _____

Sensor type(s): _____

Serial number(s): _____

Sensor length(s): _____

The sensor has been in contact with the following materials:

Do not specify chemical formulas.
Please include safety data sheets of the substances, if applicable.

In the event of suspected penetration of substances into the sensor,
consult Temposonics to determine measures to be taken before
shipment.

Short description of malfunction:

Corporate information

Company: _____

Address: _____

Contact partner

Phone: _____

Fax: _____

Email: _____

We hereby certify that the measuring equipment has been cleaned and neutralized.
Equipment handling is safe. Personnel exposure to health risks during transport and repair is excluded.

Stamp

Signature

Date

12. Appendix II

CYLINDER PORT DETAILS

PORT DETAIL (PD) FOR RH5-S:

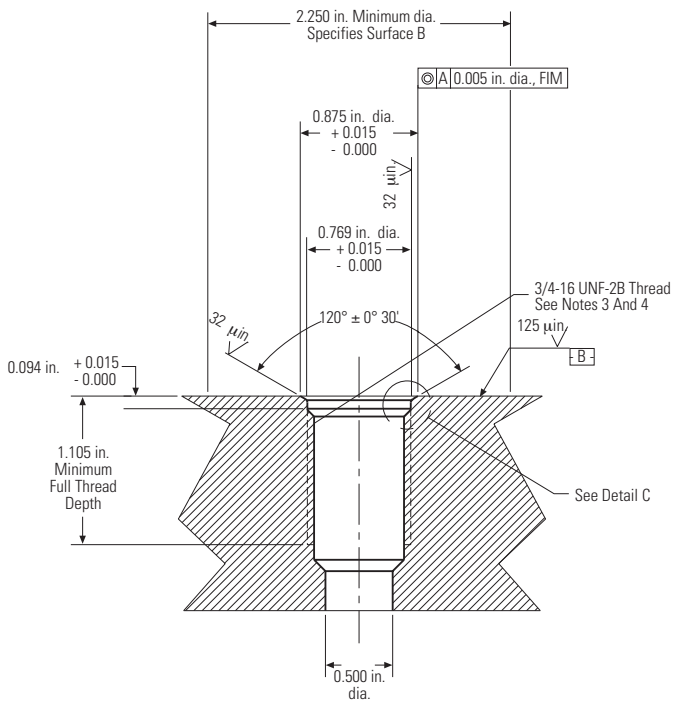

NOTES:

1. Dimensions and tolerances based on ANSI Y14.5-1982.
2. Temposonics has extracted all pertinent information from MS33649 to generate this document.
3. PD must be square with surface B within 0.005 FIM across 2.250 dia minimum.
4. PD must be concentric with 2.250 dia within 0.030 FIM and with 0.769 dia within 0.005 FIM.
5. Surface texture ANSI B46.1-1978
6. Use O-ring part number 560315 for correct sealing.
7. The thread design shall have sufficient threads to meet strength requirements of material used.
8. Finish counter-bore shall be free from longitudinal and spiral tool marks. Annular tool marks up to 32 microinches maximum will be permissible.

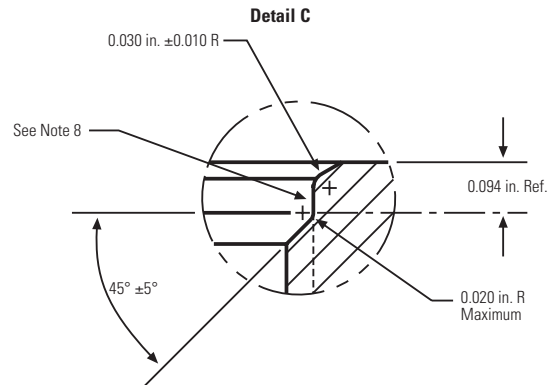

PORT DETAIL (PD) FOR RH5-T:

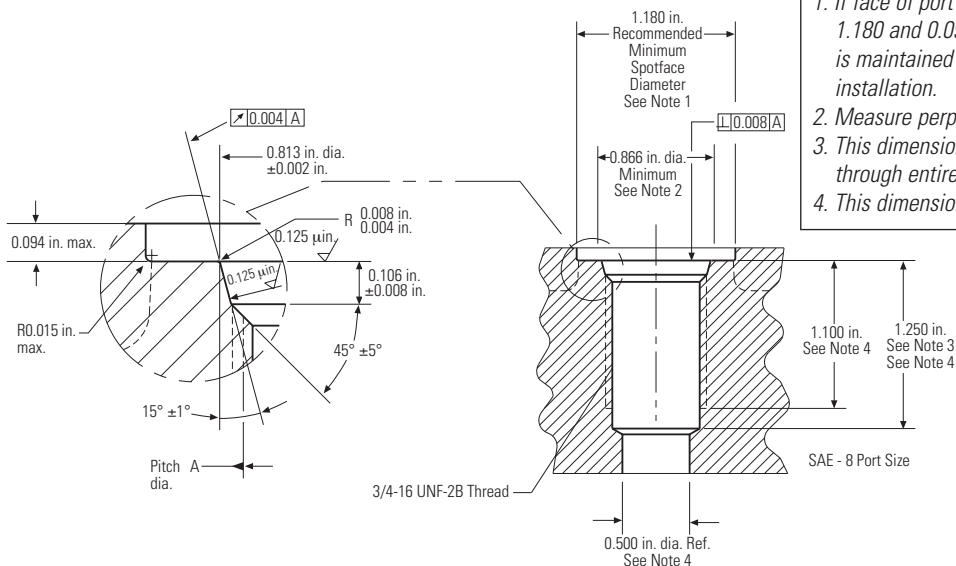

NOTES:

1. If face of port is on a machined surface, dimensions 1.180 and 0.094 need not apply as long as R0.008/0.004 is maintained to avoid damage to the O-ring during installation.
2. Measure perpendicularity to A at this diameter.
3. This dimension applies when tap drill cannot pass through entire boss.
4. This dimension does not conform to SAE J1926/1.

13. Glossary

E
<p>Encoder Profile The encoder profile corresponds to the specification of the encoder profile V4.2 (PNO no. 3.162). With this profile, the position and the velocity of one magnet can be measured and transferred simultaneously. (→ Linear Profile)</p>
<p>Extrapolation The native measurement cycle time of a sensor increases with the stroke length. With extrapolation, the sensor is able to report data faster than the native cycle time, independent of the stroke length of the sensor. Without extrapolation, if data is requested faster than the native cycle time, the last measured value is repeated.</p>
F
<p>FIR Filter The FIR filter (Finite Impulse Response) is used to smooth the measured position value before output. To determine the output value, only input values corresponding to the window (filter window size) are used for filter calculation. The output value is calculated from these input values in the form of a moving average value. (→ IIR Filter)</p>
G
<p>GSDML The properties and functions of a PROFINET IO field device are described in a GSDML file (General Station Description). The XML-based GSDML file contains all relevant data that are important for the implementation of the device in the controller as well as for data exchange during operation. The GSDML file of the R-Series V PROFINET is available on the homepage www.temposonics.com.</p>
I
<p>IIR Filter The IIR filter (Infinite Impulse Response) is used to smooth the measured position value before output. To determine the output value, the input values corresponding to the filter grade (filter window size) are used for the filter calculation. The previous values are also taken into account when calculating the output value. (→ FIR Filter)</p>
<p>Internal Linearization The internal linearization offers an improved linearity for an overall higher accuracy of the position measurement. The internal linearization is set for the sensor during production.</p>
<p>IRT With PROFINET IRT (Isochronous Real Time) a clock-synchronous data transmission takes place. The application, the data transmission as well as the device cycle are synchronous. IRT enables a clock-synchronous data exchange with a minimum cycle time of 250 µs in the network. The R-Series V PROFINET supports PROFINET RT and IRT. (→ RT)</p>
L
<p>Linear Profile The linear profile was developed by Temposonics and is tailored to the characteristics of magnetostrictive position sensors. With this profile, the positions and velocities of up to 30 magnets can be reported and transferred simultaneously. (→ Encoder Profile)</p>

M
<p>Measuring Direction When moving the position magnet, the position and velocity values increase in the measuring direction.</p> <ul style="list-style-type: none"> • Forward: Values increasing from sensor electronics housing to rod end/profile end • Reverse: Values increasing from rod end/profile end to sensor electronics housing
<p>Multi-position measurement During the measurement cycle, the positions of every magnet on the sensor are simultaneously reported. The velocity is continuously calculated based on these changing position values as the magnets are moved.</p>
O
<p>Offset A value which will be added or deducted to the actual position value. This leads to a shift of the measurement range start. (→ Preset)</p>
P
<p>PLC A PLC (Programmable Logic Controller) is a device for controlling or regulating machines and systems.</p>
<p>Preset With the preset, a value is entered for the current position which is to be output at this position in the future. The difference between the entered value and the currently measured position is calculated as an offset. (→ Offset)</p>
<p>PROFINET PROFINET (Process Field Network) is an Industrial Ethernet interface and is managed by the PROFIBUS Nutzerorganisation e.V. (PNO). The R-Series V PROFINET and its corresponding GSDML file are certified by the PNO.</p>
R
<p>RO RO (Read Only) means that the value of the variable can only be read but is not modifiable.</p>
<p>RT With PROFINET RT (Real Time) the data exchange is without clock synchronization. In this case, the application, the data transmission and the field devices operate according to their own processing cycle. The R-Series V PROFINET supports PROFINET RT and IRT. (→ IRT)</p>
<p>RW RW (Read/Write) means that the value of the variable can be read and written. The value of the variable is modifiable.</p>

UNITED STATES
Temposonics, LLC
Americas & APAC Region
3001 Sheldon Drive
Cary, N.C. 27513
Phone: +1 919 677-0100
E-mail: info.us@temposonics.com

GERMANY
Temposonics
GmbH & Co. KG
EMEA Region & India
Auf dem Schüffel 9
58513 Lüdenscheid
Phone: +49 2351 9587-0
E-mail: info.de@temposonics.com

ITALY
Branch Office
Phone: +39 030 988 3819
E-mail: info.it@temposonics.com

FRANCE
Branch Office
Phone: +33 6 14 060 728
E-mail: info.fr@temposonics.com

UK
Branch Office
Phone: +44 79 21 83 05 86
E-mail: info.uk@temposonics.com

SCANDINAVIA
Branch Office
Phone: +46 70 29 91 281
E-mail: info.sca@temposonics.com

CHINA
Branch Office
Phone: +86 21 2415 1000 / 2415 1001
E-mail: info.cn@temposonics.com

JAPAN
Branch Office
Phone: +81 3 6416 1063
E-mail: info.jp@temposonics.com

Document Part Number:
551973 Revision E (EN) 12/2022



temposonics.com