

Temposonics®

Magnetostrictive Linear Position Sensors

RT4 SSI Data Sheet

- Redundant SSI output
- High temperature rod
- IP68 ingress protection



MEASURING TECHNOLOGY

For position measurement, the absolute, linear Temposonics® position sensors make use of the properties offered by the specially designed magnetostrictive waveguide. Inside the sensor a torsional strain pulse is induced in the waveguide by momentary interaction of two magnetic fields. The interaction between these two magnetic fields produces a strain pulse, which is detected by the electronics at the head of the sensor. One field is produced by a moving position magnet, which travels along the sensor rod with the waveguide inside. The other field is generated by a current pulse applied to the waveguide. The position of the moving magnet is determined precisely by measuring the time elapsed between the application of the current pulse and the arrival of the strain pulse at the sensor electronics housing. The result is a reliable position measurement with high accuracy and repeatability.

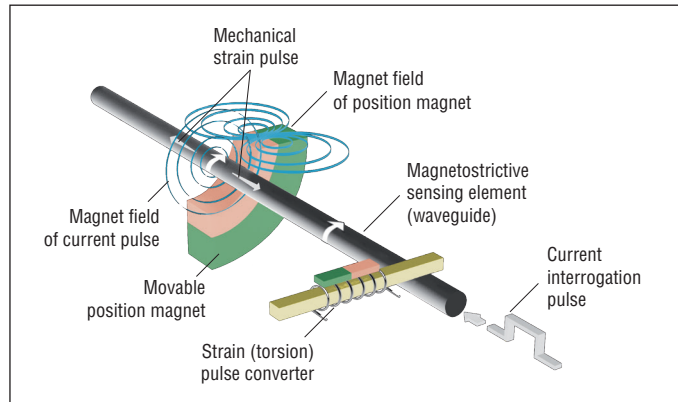

Fig. 1: Time-based magnetostrictive position sensing principle

RT4 SENSOR

Robust, non-contact and wear-free, the Temposonics® linear position sensors provide best durability and accurate position measurement solutions in harsh industrial environments. Designed for demanding applications that require redundancy and detached electronics due to high temperature or high reliability requirements. The position measurement accuracy is tightly controlled by the quality of the waveguide which is manufactured by Temposonics. The position magnet is mounted on the moving machine part and travels contactlessly over the sensor rod with the built-in waveguide.

RT4 sensor specifications:

- Redundant R-series detached electronics for enhanced safety applications
- High temperature rod (up to +100 °C)
- Detached electronics up to 600 mm from sensor rod
- IP68 ingress protection
- Linear, absolute measurement
- Non-contact sensing technology
- Linearity deviation less than 0.02 %
- Direct 24/25/26 bit SSI output, gray/binary formats
- LEDs for sensor status and diagnostics

Applications:

- Steel, wood, power generation, fluid power



Fig. 2: Typical application: metal processing

TECHNICAL DATA

Output													
Interface	SSI (Synchronous Serial Interface) - differential signal in SSI standard (RS 422)												
Data protocol	Binary or Gray, optional: parity and error bit												
Data length	24, 25, or 26 bit												
Data transmission rate	70 kBaud *...1 MBaud, depending on cable length: <table border="1"> <thead> <tr> <th>Length</th> <th>< 3</th> <th>< 50</th> <th>< 100</th> <th>< 200</th> <th>< 400 m</th> </tr> </thead> <tbody> <tr> <td>Baud rate</td> <td>1 MBd</td> <td>< 400 kBd</td> <td>< 300 kBd</td> <td>< 200 kBd</td> <td>< 100 kBd</td> </tr> </tbody> </table>	Length	< 3	< 50	< 100	< 200	< 400 m	Baud rate	1 MBd	< 400 kBd	< 300 kBd	< 200 kBd	< 100 kBd
Length	< 3	< 50	< 100	< 200	< 400 m								
Baud rate	1 MBd	< 400 kBd	< 300 kBd	< 200 kBd	< 100 kBd								
Measured value	Position												
Measurement parameters													
Resolution	1 µm, 2 µm, 5 µm, 10 µm, 20 µm, 50 µm, 100 µm												
Cycle times	<table border="1"> <thead> <tr> <th>Stroke length</th> <th>300</th> <th>750</th> <th>1000</th> <th>2000 mm</th> </tr> </thead> <tbody> <tr> <td>Measurement rate</td> <td>3.7</td> <td>3.0</td> <td>2.3</td> <td>1.2 kHz</td> </tr> </tbody> </table>	Stroke length	300	750	1000	2000 mm	Measurement rate	3.7	3.0	2.3	1.2 kHz		
Stroke length	300	750	1000	2000 mm									
Measurement rate	3.7	3.0	2.3	1.2 kHz									
Linearity ¹	< ±0.02 % F.S. (minimum ±50 µm)												
Repeatability	0.001 % F.S. (minimum ±2.5 µm)												
Operating conditions													
Operating temperature	Sensor electronics: -40 °C (-40 °F) to +75 °C (+167 °F) Sensor rod with interconnection cable: -40 °C (-40 °F) to +100 °C (+212 °F)												
Humidity	90% humidity, no condensation												
Ingress protection	Sensor electronics: IP67 (with professionally mounted housing and connectors) Sensor housing with interconnection cable: IP68												
Shock test	100 g (single hit) / IEC standard 60068-2-27												
Vibration test	10 g / 10 to 2000 Hz, IEC standard 60068-2-6 (resonance frequencies excluded)												
EMC test ²	Electromagnetic emission: IEC/EN 50081-1 Electromagnetic susceptibility: IEC/EN 50082-2 IEC/EN 61000-4-2/3/4/6, level 3/4 criterium A												
Magnet movement velocity ¹	Any												
Design/Material													
Sensor electronics	Aluminum housing with diagnostic LED display. (LEDs located beside connector/cable exit)												
Sensor housing	Stainless steel 1.4305, AISI 304L												
Stroke length	25...2540 mm (1...100 in.)												
Operating pressure	350 bar static, 690 bar peak (5000 psi, 10,000 psi peak)												
Mechanical mounting													
Mounting position	Any orientation												
Mounting instruction	Please consult the technical drawings												
Electrical connection													
Connection type	7 pin connector M16 or integral cable												
Operating voltage	+24 VDC (-15% / +20 %)												
Ripple	≤ 0.28 Vpp												
Current consumption	100 mA per sensor electronics												
Dielectric strength	500 VDC (DC ground to machine ground)												
Polarity protection	up to -30 VDC												
Overvoltage protection	up to 36 VDC												

* / with standard monoflop of 16 µs

1 / With position magnet # 201 542-2

2 / Sensor rod and interconnection cable are mounted in a metal housing (e.g. in a cylinder).

TECHNICAL DRAWINGS (Detached electronics with side cable entry)

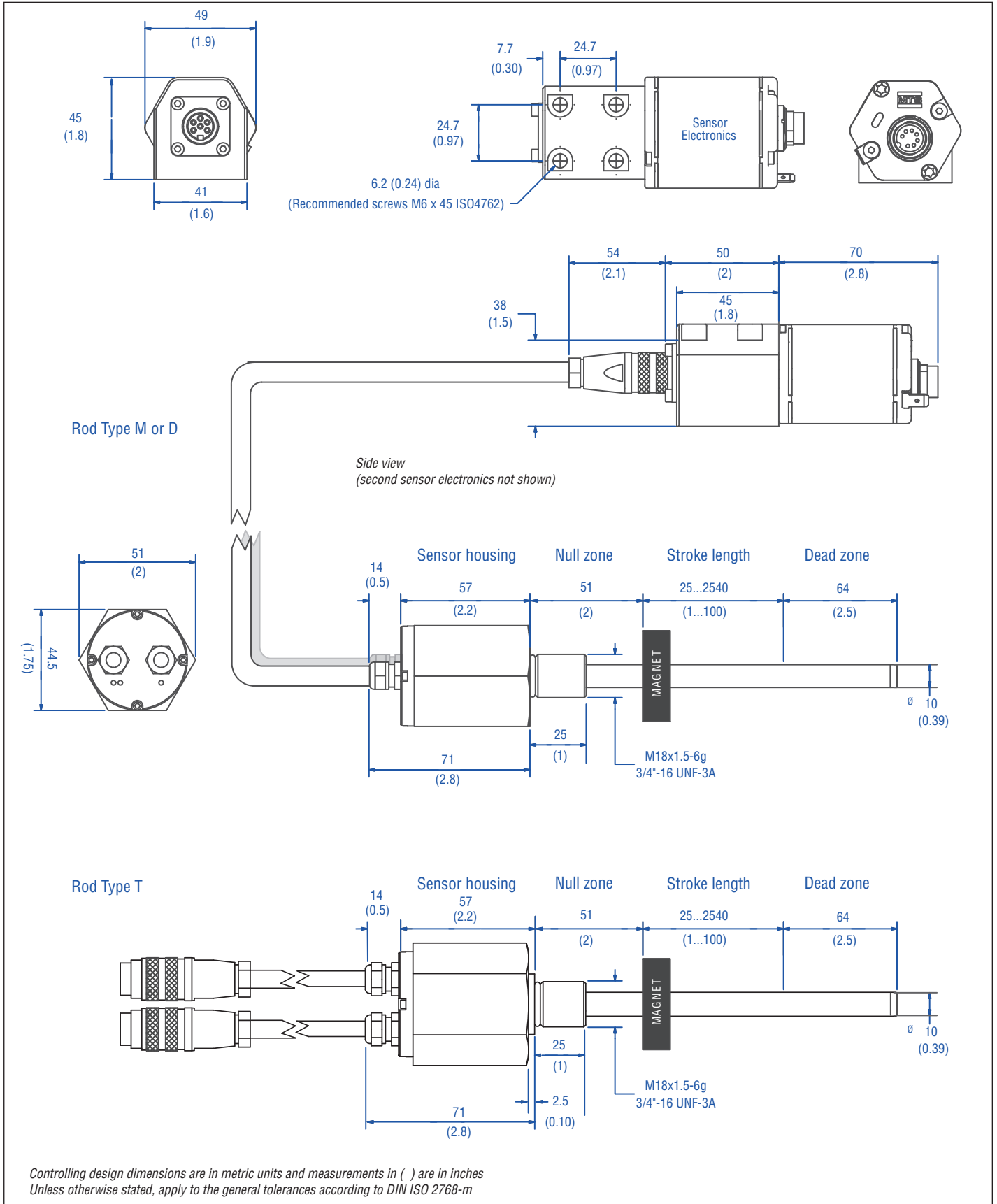

Controlling design dimensions are in metric units and measurements in () are in inches
 Unless otherwise stated, apply to the general tolerances according to DIN ISO 2768-m

CONNECTOR WIRING

M16 connector

D70	Pin	Function
	1	Data (-)
	2	Data (+)
	3	Clock (+)
	4	Clock (-)
	5	+24 VDC (-15 / +20 %)
	6	DC Ground (0 V)
	7	n.c.

Cable outlet

Cable	Function
GY	Data (-)
PK	Data (+)
YE	Clock (+)
GN	Clock (-)
BN	+24 VDC (-15 / +20 %)
WH	DC Ground (0 V)

FREQUENTLY ORDERED ACCESSORIES – Additional options available in our [Accessories Catalog](#) [550929](#)

Position magnets

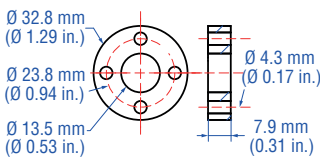
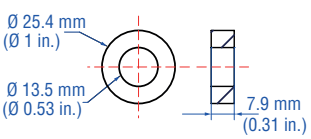
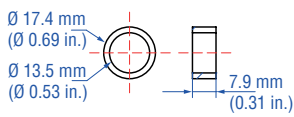
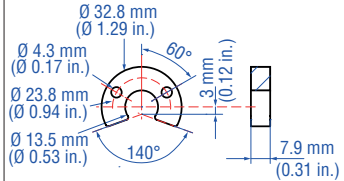
			
Standard ring magnet 0032.8 Part no. 201 542-2	Ring magnet OD25.4 Part no. 400 533	Ring magnet OD17.4 Part no. 401 032	U-magnet OD33 Part no. 251 416-2
Material: PA ferrite GF20 Weight: ca. 14 g Operating temperature: -40...+105 °C (-40...+221 °F) Surface pressure: max. 40 N/mm ² Fastening torque for M4 screws: max. 1 Nm	Material: PA ferrite Weight: ca. 10 g Operating temperature: -40...+105 °C (-40...+221 °F) Surface pressure: max. 40 N/mm ²	Material: PA neobind Weight: ca. 5 g Operating temperature: -40...+105 °C (-40...+221 °F) Surface pressure: max. 20 N/mm ²	Material: PA ferrite GF20 Weight: ca. 11 g Operating temperature: -40...+105 °C (-40...+221 °F) Surface pressure: max. 40 N/mm ² Fastening torque for M4 screws: max. 1 Nm

Optional installation hardware

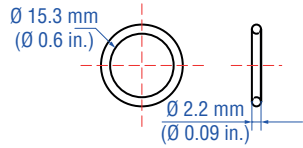
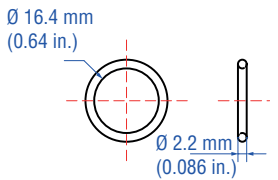
	
O-ring Part no. 401 133	O-ring Part no. 560 315
Material: Fluoroelastomer 75 ± 5 durometer Application: M-style housings	Material: Fluoroelastomer 75 ± 5 durometer Application: T and D -style housings

Controlling design dimensions are always in metric units

ORDER CODE

1	2	3	4	5	6	7	8	9	10	11	12	13	14	15	16	17	18	19	20	21	22	23	24	25	
R	T	4				E									S										
a			b	c			d	e				f			g										

23, 24, 25 optional

a Sensor model

R T 4 Rod version

b Sensor rod style

M Flat faced Metric threaded flange, M18x1.5
 D Flat faced US customary threaded flange, 3/4"-16
 T Raised face US customary threaded flange, 3/4"-16

c Sensor rod interconnection cable

B 1 250 mm (9.8 in.) Santoprene cable, hanging connector
 B 2 400 mm (15.7 in.) Santoprene cable, hanging connector
 B 3 600 mm (23.6 in.) Santoprene cable, hanging connector

d Electronics housing style

E Side cable electronics connection

e Stroke length

X X X X M for mm (0025...2540 mm in 5 mm increments)
 X X X X U for inches (001.0...100.0 in. in 0.1 in. increments)

f Connection type

Integral connector

D 7 0 7pin M16 connector

Integral Cables (box No. 13, 14, 15)

P Integral high-performance cable, orange jacket with pigtail termination

R Integral cable, PVC jacket, pigtail termination, standard

F Integral cable, black polyurethane jacket with pigtail termination

Cable length

Encode in feet if using US customary stroke length
 Encode in meters if using metric stroke length

3 (03) to 98 (98) ft. or 1 (01) to 30 (30) meters.

Operating voltage

Without selection input voltage, 24 VDC

g Output

S(17)(18)(19)(20)(21)(22)(23)(24)(25) = Synchronous Serial Interface

Data length (box no. 17)

1 25 bits
 2 24 bits
 3 26 bits

g Output (continued)

S(17)(18)(19)(20)(21)(22)(23)(24)(25) = Synchronous Serial Interface

Format (box no. 18)

B Binary
 G Gray

Resolution (box no. 19)

1 0.005 mm
 2 0.01 mm
 3 0.05 mm
 4 0.1 mm
 5 0.02 mm
 6 0.002 mm
 8 0.001 mm

Filtering performance (box no. 20)

8 Noise reduction filter (8 values)
 G Noise reduction filter (8 values) + error delay 10 cycles

Signal options (box no. 21 and 22)

0 0 Measuring direction forward
 0 1 Measuring direction reverse
 0 2 Measuring direction forward, synchronized measurement
 0 5 Measuring direction forward, Bit 25 = Alarm, Bit 26 = Parity even
 9 9 Advanced Signal Options (Use next fields 23, 24, 25)

Measurement contents (box no. 23)

1 Position

Direction and Sync mode (box no. 24)

1 Forward async
 2 Forward sync1
 5 Reverse async
 6 Reverse sync1

Communication Diagnostics (box no. 25)

0 No further option
 2 Additional alarm bit + parity even bit

DELIVERY



Sensor, O-ring

Accessories have to be ordered separately.

Operation manuals & software are available at:

www.temposonics.com

UNITED STATES 3001 Sheldon Drive
Temposonics, LLC Cary, N.C. 27513
Americas & APAC Region Phone: +1 919 677-0100
E-mail: info.us@temposonics.com

GERMANY Auf dem Schüffel 9
Temposonics 58513 Lüdenscheid
GmbH & Co. KG Phone: +49 2351 9587-0
EMEA Region & India E-mail: info.de@temposonics.com

ITALY Phone: +39 030 988 3819
Branch Office E-mail: info.it@temposonics.com

FRANCE Phone: +33 6 14 060 728
Branch Office E-mail: info.fr@temposonics.com

UK Phone: +44 79 21 83 05 86
Branch Office E-mail: info.uk@temposonics.com

SCANDINAVIA Phone: +46 70 29 91 281
Branch Office E-mail: info.sca@temposonics.com

CHINA Phone: +86 21 2415 1000 / 2415 1001
Branch Office E-mail: info.cn@temposonics.com

JAPAN Phone: +81 3 6416 1063
Branch Office E-mail: info.jp@temposonics.com

Document Part Number:
551756 Revision B (EN) 07/2015



temposonics.com