

Data Sheet

MH-Series MH Threaded CANbus

Magnetostrictive Linear Position Sensors

- Stroke length up to 2500 mm
- Available with M18×1.5 and ¾"-16 mounting thread
- Sensor rod with Ø 7 mm or Ø 10 mm
- Rugged to withstand off-highway shock & vibration
- M12 connector or cable output

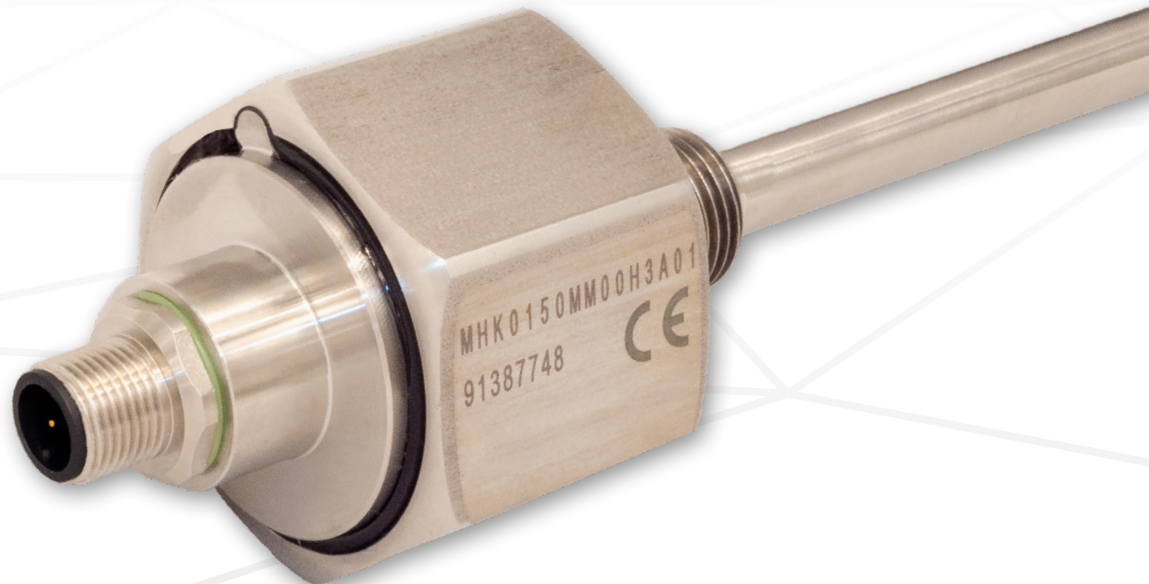

MEASURING TECHNOLOGY

The absolute, linear position sensors provided by Temposonics rely on the company's proprietary magnetostrictive technology, which can determine position with a high level of precision and robustness. Each Temposonics position sensor consists of a ferromagnetic waveguide, a position magnet, a strain pulse converter and supporting electronics. The magnet, connected to the object in motion in the application, generates a magnetic field at its location on the waveguide. A short current pulse is applied to the waveguide. This creates a momentary radial magnetic field and torsional strain on the waveguide. The momentary interaction of the magnetic fields releases a torsional strain pulse that propagates the length of the waveguide. When the ultrasonic wave reaches the end of the waveguide it is converted into an electrical signal. Since the speed of the ultrasonic wave in the waveguide is precisely known, the time required to receive the return signal can be converted into a linear position measurement with both high accuracy and repeatability.

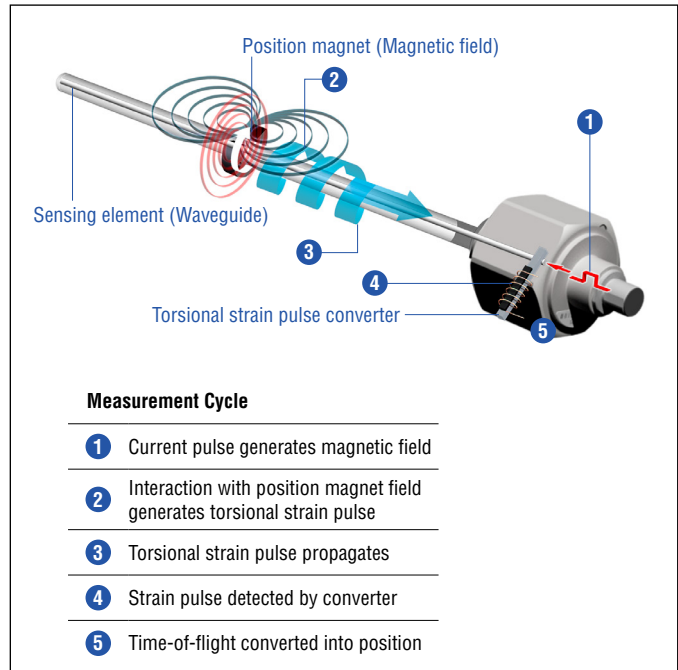

Fig. 1: Time-of-flight based magnetostrictive position sensing principle

MH THREADED SENSOR

The Temposonics® MH-Series sensors are specifically designed for direct stroke measurement in hydraulic cylinders. The MH Threaded sensor extends the rugged design of the Temposonics® MH Series sensors to external threaded installations. A M12 connector system ensures protection to IP69K. The inherent absolute capabilities ensure that the MH Threaded sensor is always ready. With two connection styles, the responsive magnetostrictive linear position sensors can be integrated into most installations.

Temposonics® MH Threaded sensors can be used in applications where access is available from the outside of the cylinder. Example applications include lift and tilt cylinders, hydraulic jacks, and hydraulic steering systems in agricultural and construction machinery.



Fig. 2: Typical applications

TECHNICAL DATA

Input				
Signal characteristic	Bus-protocol: SAE J1939, CANopen protocol according CiA DS-301 V4.1, device profile DS-406 V3.1			
Measured value	Position & velocity			
Output				
Resolution (position)	0.1 mm			
Resolution (velocity)	1 mm/s			
Boot up time	Typ. 400 ms			
Cycle time	Output	CANopen	SAE J1939	
	Cycle time	1 ms	20 ms	
Linearity	Stroke length	50...250 mm	255...2000 mm	2005...2500 mm
	Linearity	≤ ±0.1 mm	±0.04 % F.S.	≤ ±0.8 mm
Internal sample rate	1 ms			
Setpoint tolerance	±0.2 mm			
Operating conditions				
Operating temperature electronics	-40...+105 °C			
Storage temperature	-25...+65 °C			
Fluid temperature	-40...+85 °C			
Humidity	90 % relative humidity, no condensation, EN60068-2-30			
Ingress protection – M12 connector	IP67/IP69K (connectors correctly fitted), EN60529			
Ingress protection – Sensor housing	IP67/IP69K, EN60529			
Shock	100 g (11 ms) single shock, 50 g (11 ms) at 1000 shocks per axis, IEC 60068-2-27			
Vibration test (IEC 60068-2-64)	Ø 7 mm sensor rod		Ø 10 mm sensor rod	
	15 g (r.m.s.) (10...2000 Hz)		20 g (r.m.s.) (10...2000 Hz)	
EMC	2009/64/EG Road vehicles			
	2009/19/EG Agricultural and Forest machines			
	ISO 14982 Emissions/Immunity			
	ISO 7637-1/2 Transient Impulses ISO / TR 10605 Electrostatic Discharge (E.S.D.)			
Pressure (according to DIN EN ISO 19879)*	Ø 7 mm sensor rod		Ø 10 mm sensor rod	
PN (nominal operating)	300 bar		320 bar	
P _{MAX} (max. overload)	400 bar		400 bar	
P _{STATIC} (proof pressure)	525 bar		550 bar	
Design/Material				
Sensor electronics housing	Stainless steel 1.4305 (AISI 303)			
Sensor rod – Ø 7 mm	Stainless steel 1.4301 (AISI 304)			
Sensor rod – Ø 10 mm	Stainless steel 1.4306 (AISI 304L)			
Stroke length	50...2500 mm			
Mounting position	Any			
Mounting instruction	Please consult the technical drawings			

* / According to calculations under use of the FKM guideline

Cycles	Ø 7 mm sensor rod	Ø 10 mm sensor rod
Dynamic pressure: < 2 × 10 ⁶ pressure cycles	300 bar	320 bar
Static pressure: < 2 × 10 ⁴ pressure cycles	400 bar	400 bar
Proof pressure: Maximum 5 minutes testing time for cylinder pressure test	525 bar	550 bar

MH-H with M12 connector: Rod: Ø 7 mm / Dead zone: 63.5 mm

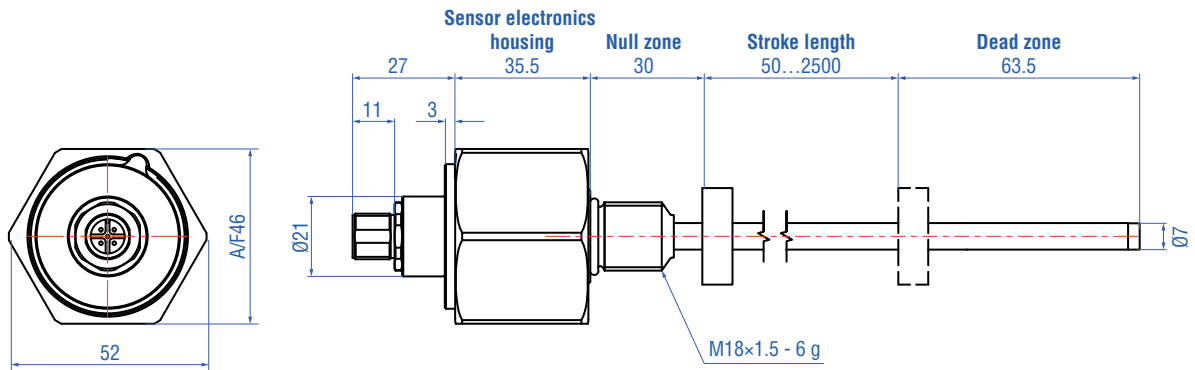

MH-H with cable outlet: Rod: Ø 7 mm / Dead zone: 63.5 mm

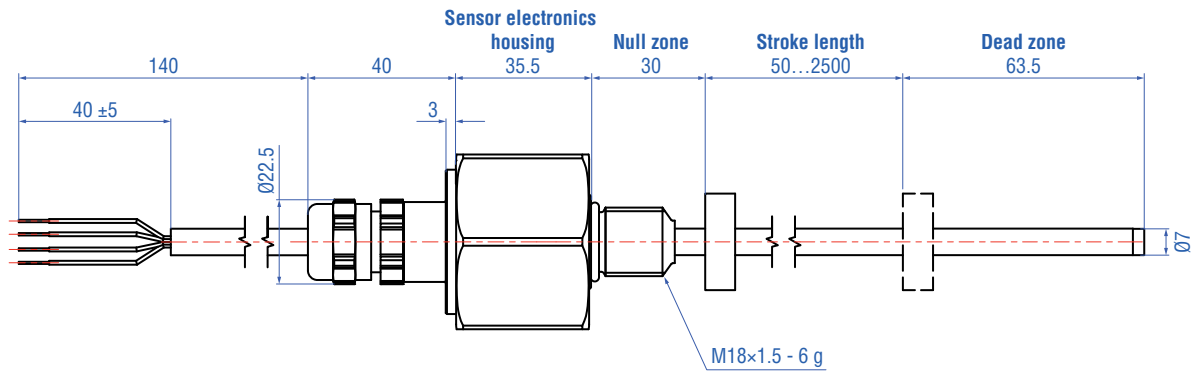

Controlling design dimensions are in millimeters

Fig. 4: Temposonics® MH-Series MH Threaded (MH-H)

MH-K with M12 connector: Rod: Ø 10 mm + end plug with female M6 thread / Dead zone: 52.5 mm

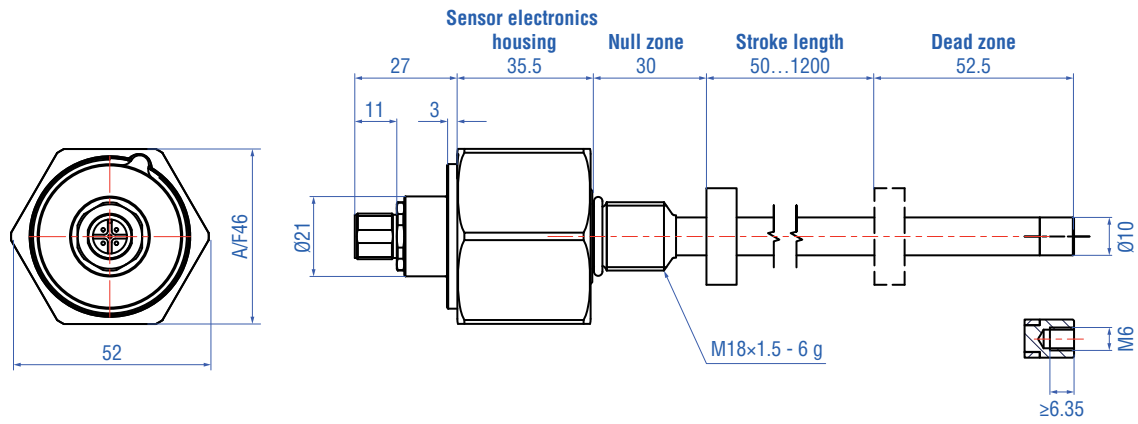

MH-K with threaded flange M18×1.5: Rod: Ø 10 mm + end plug with female M6 thread / Dead zone: 52.5 mm

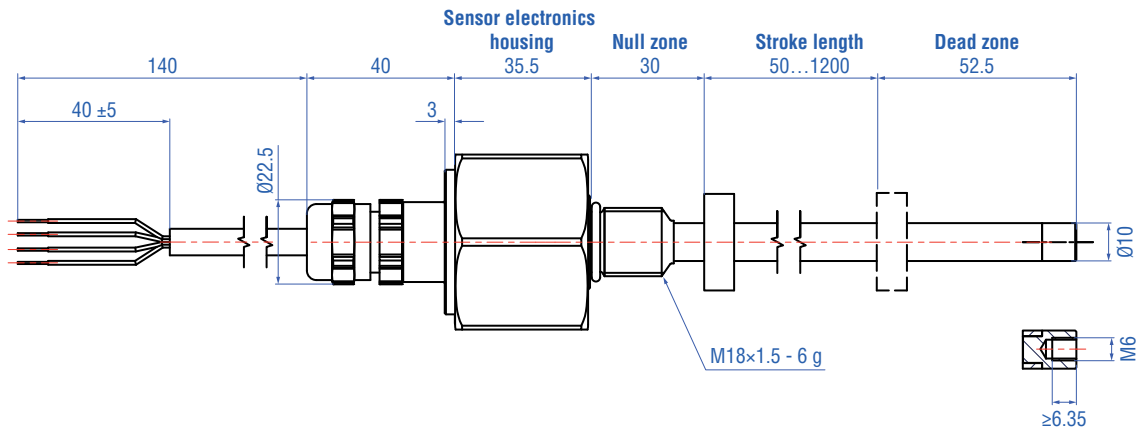

Controlling design dimensions are in millimeters

Fig. 5: Temposonics® MH-Series MH Threaded (MH-K)

MH-N with M12 connector: Rod: Ø 10 mm / Dead zone: 63.5 mm

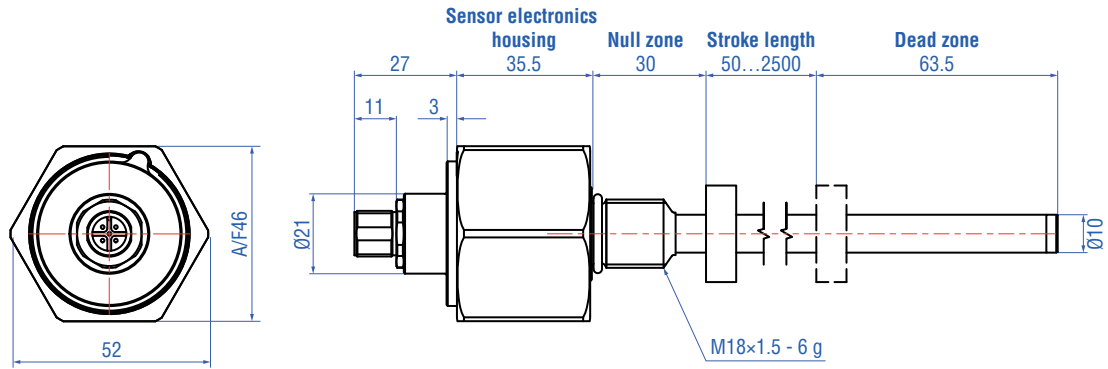

MH-N with threaded flange M18x1.5: Rod: Ø 10 mm / Dead zone: 63.5 mm

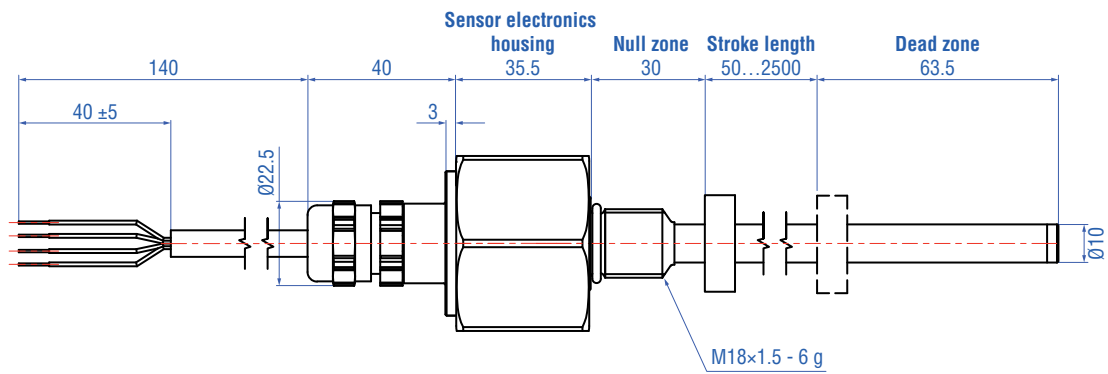

Controlling design dimensions are in millimeters

Fig. 6: Temposonics® MH-Series MH Threaded (MH-N)

MH-P with M12 connector: Rod: Ø 7 mm / Dead zone: 45.5 mm

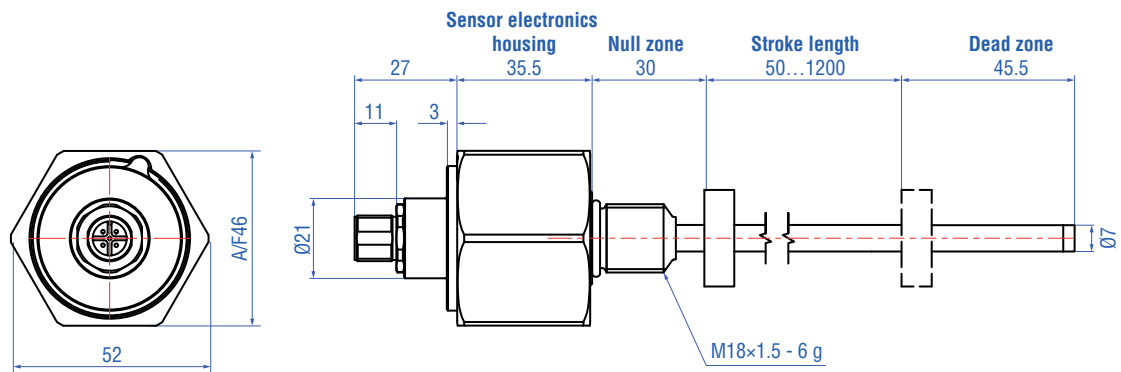

MH-P with cable outlet: Rod: Ø 7 mm / Dead zone: 45.5 mm

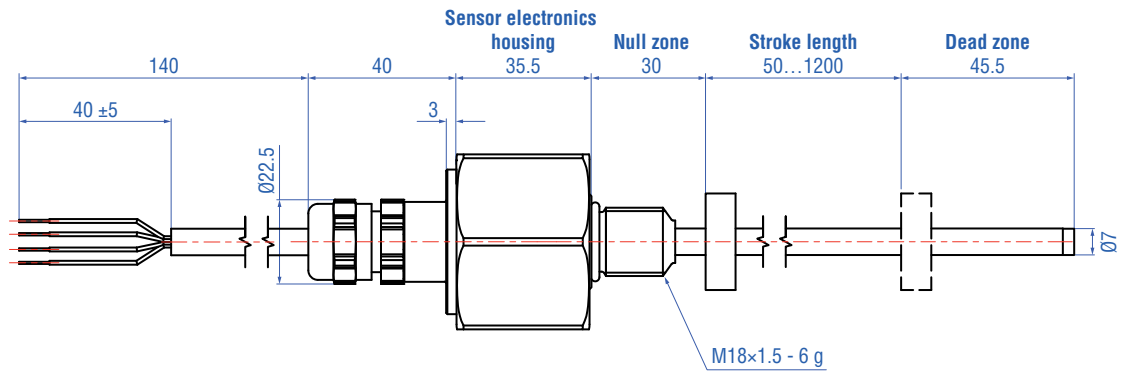

Controlling design dimensions are in millimeters

Fig. 7: Temposonics® MH-Series MH Threaded (MH-P)

MH-T with M12 connector: Rod: Ø 10 mm / Dead zone: 45.5 mm

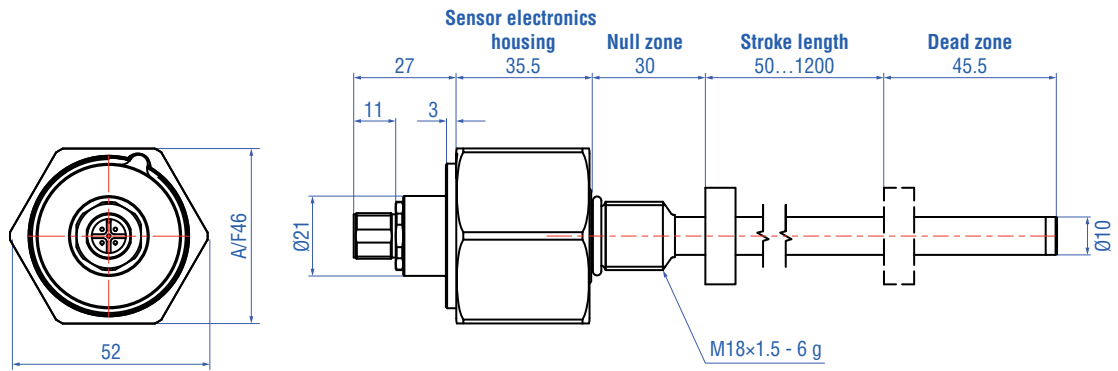

MH-T with cable output: Rod: Ø 10 mm / Dead zone: 45.5 mm

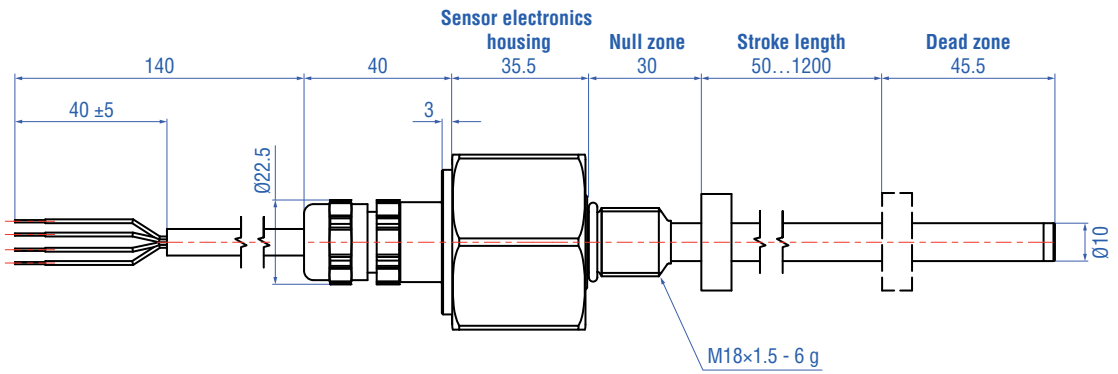

Controlling design dimensions are in millimeters

Fig. 8: Temposonics® MH-Series MH Threaded (MH-T)

MH-W with M12 connector: Rod: Ø 10 mm / Dead zone: 63.5 mm

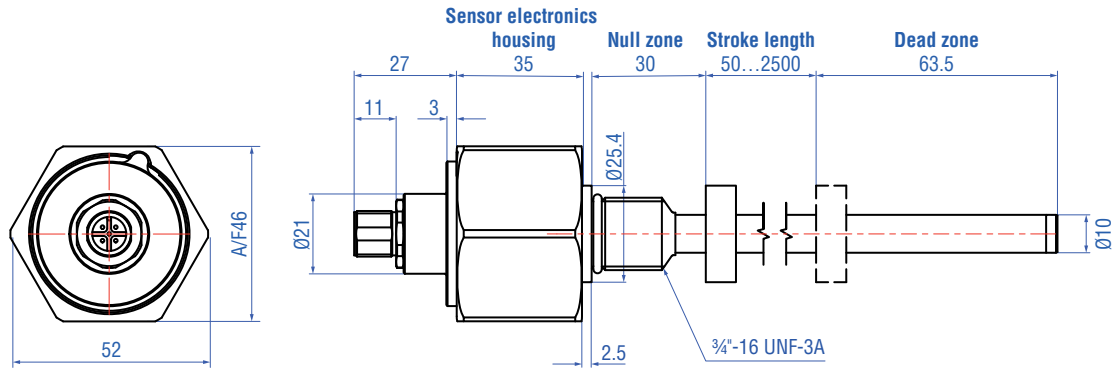

MH-W with cable outlet: Rod: Ø 10 mm / Dead zone: 63.5 mm

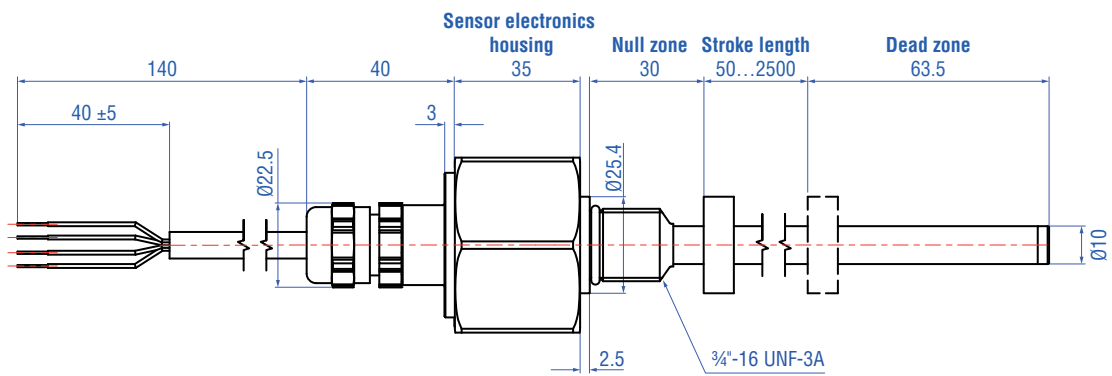

Controlling design dimensions are in millimeters

Fig. 9: Temposonics® MH-Series MH Threaded (MH-W)

CONNECTOR WIRING



M12 connector (M00F)														
	<ul style="list-style-type: none"> Attached A-coded M12 connector attached Toolless assembly Sealing IP67, up to IP69K on plugged mating connector 													
	<table border="1"> <thead> <tr> <th>Connector wiring</th> <th>M00F</th> </tr> <tr> <th>Pin</th> <th>Function</th> </tr> </thead> <tbody> <tr> <td>1</td> <td>do not connect</td> </tr> <tr> <td>2</td> <td>VDC</td> </tr> <tr> <td>3</td> <td>GND</td> </tr> <tr> <td>4</td> <td>CAN_H</td> </tr> <tr> <td>5</td> <td>CAN_L</td> </tr> </tbody> </table>	Connector wiring	M00F	Pin	Function	1	do not connect	2	VDC	3	GND	4	CAN_H	5
Connector wiring	M00F													
Pin	Function													
1	do not connect													
2	VDC													
3	GND													
4	CAN_H													
5	CAN_L													
 View on connector														
Pigtail cable (C...A)														
	<ul style="list-style-type: none"> PUR cable Ø 5 mm, non-shielded, 3 × 0.5 mm² Flexible, oil resistance 													
	<table border="1"> <thead> <tr> <th>Connector wiring</th> <th>C...A</th> </tr> <tr> <th>Pin</th> <th>Function</th> </tr> </thead> <tbody> <tr> <td>BN</td> <td>VDC</td> </tr> <tr> <td>WH</td> <td>GND</td> </tr> <tr> <td>GN</td> <td>CAN_L</td> </tr> <tr> <td>YE</td> <td>CAN_H</td> </tr> </tbody> </table>	Connector wiring	C...A	Pin	Function	BN	VDC	WH	GND	GN	CAN_L	YE	CAN_H	
Connector wiring	C...A													
Pin	Function													
BN	VDC													
WH	GND													
GN	CAN_L													
YE	CAN_H													
														

Fig. 10: Connector wiring

Connection schematics	
<p>To ensure proper operation of the sensor, the hydraulic cylinder must be connected to the machine ground. Grounding is often ensured by the mechanical contact between the cylinder and other machine elements. If the cylinder is connected with the machine separately, separate grounding, for example via a grounding strap directly on the cylinder must be ensured.</p>	

Fig. 11: Connection schematics

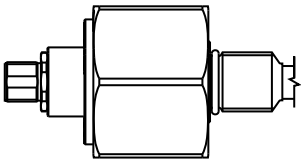
FREQUENTLY ORDERED ACCESSORIES

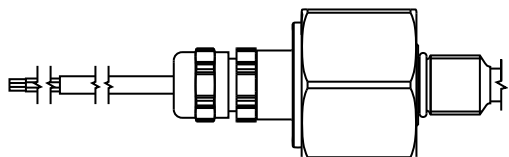
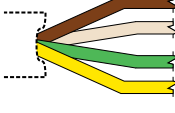
Position magnets		Float	
			
Ring magnet OD17.4 Part no. 401 032	Ring magnet OD25.4 Part no. 400 533	Ring magnet OD33 Part no. 201 542-2	Float Part no. 561 612
Material: PA neobond Weight: Approx. 5 g Surface pressure: Max. 20 N/mm ² Operating temperature: -40...+105 °C (-40...+221 °F)	Material: PA ferrite Weight: Approx. 10 g Surface pressure: Max. 40 N/mm ² Operating temperature: -40...+105 °C (-40...+221 °F)	Material: PA ferrite GF20 Weight: Approx. 14 g Surface pressure: Max. 40 N/mm ² Fastening torque for M4 screws: 1 Nm Operating temperature: -40...+105 °C (-40...+221 °F)	Material: Stainless steel (AISI 304) Density: 720 kg/m ³ Weight: Ca. 42 g Specific gravity: Max. 0.61 Pressure: Max. 40 bar Operating temperature: -40...+125 °C
Floats		Float kits	
			
Float Part no. 254 886	Float Part no. 201 611	Float kit for Ø 7 mm Part no. 201 971	Float kit for Ø 10 mm Part no. 201 971-2
Material: PP, Moplen5, red Specific gravity: Max. 0.53 g/cm ³ Pressure: Max. 4 bar Weight: Ca. 23 g Operating temperature: -20...+80 °C	Material: Stainless steel 1.4404 (AISI 316L) Specific gravity: Max. 0.83 Weight: ca. 10.5 g	Kit includes: <ul style="list-style-type: none"> • Mounting flange (5 bolt) for sensors with M18×1.5 thread (part no. 404 205) • Stop collar for Ø 7 mm (part no. 562 077) • Float (part no. 201 611) 	Kit includes: <ul style="list-style-type: none"> • Mounting flange (5 bolt) for sensors with M18×1.5 thread (part no. 404 205) • Stop collar for Ø 10 mm (part no. 560 777) • Float (part no. 561 612)
Flange		Collar	
			
Mounting flange (5 bolt) for sensors with M18×1.5 thread Part no. 404 205	Stop collar for Ø 10 mm Part no. 560 777	Stop collar for Ø 7 mm Part no. 562 077	
Material: Stainless Steel 1.4305 (AISI 303)	Provides end of stroke stops for float Material: Stainless steel 1.4301 (AISI 304) Weight: Approx. 30 g Hex key 7/64" required	Provides end of stroke stops for float Material: Stainless steel 1.4305 (AISI 303) Weight: Approx. 30 g Hex key 2.5 mm required	

Test kits

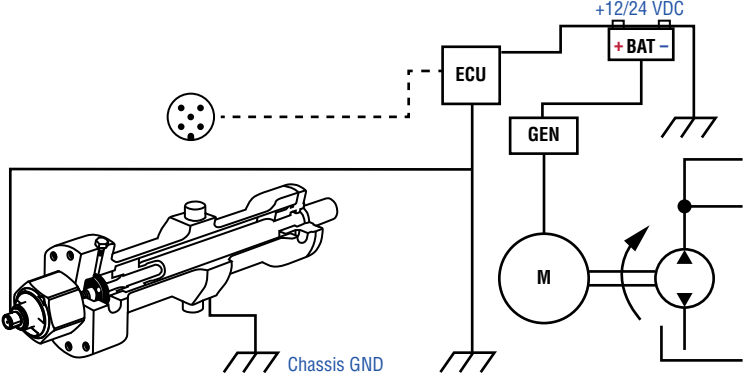
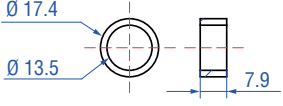
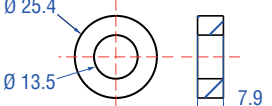
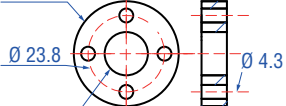
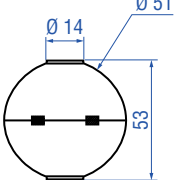
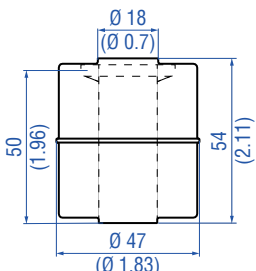
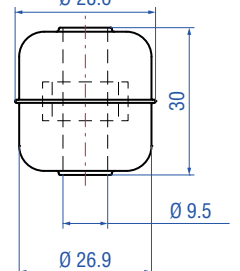
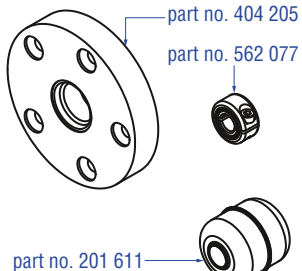
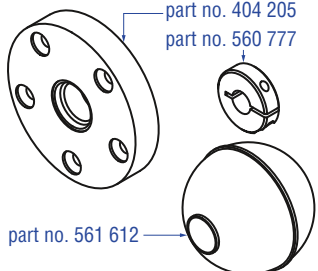
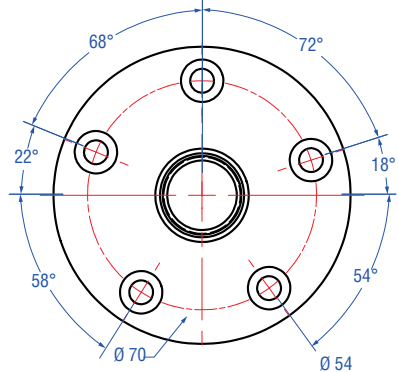
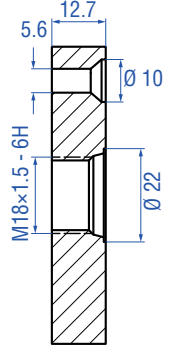
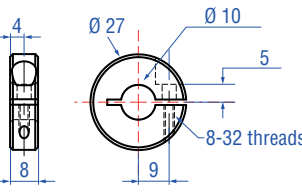
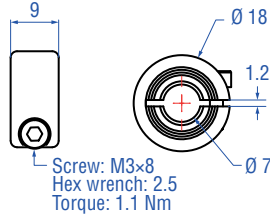

Testkit CANbus for US
Part no. 253 879

Kit includes:
1 × USB CAN-Modul
1 × USB CAN-Modul Utility CD
(driver & manual)
1 × USB cable
cable with M12 connector and
RS232 connector
1 × cable with RS232 connector
1 × carrying case
1 × 12 VDC power supply



Testkit CANbus for EU
Part no. 254 267

Kit includes:
1 × USB CAN-Modul
1 × USB CAN-Modul Utility CD
(driver & manual)
1 × USB cable
cable with M12 connector
and RS232 connector
1 × cable with RS232 connector
1 × carrying case
1 × 12 VDC power supply

Cables



**Cable with M12 A-coded female
connector (5 pin), straight – pigtail**
Part no. 370 673

Material: PUR jacket; black
Features: Shielded
Cable length: 5 m (16.4 ft)
Ingress protection: IP67 (correctly fitted)
Operating temperature:
-25...+80 °C (-13...+176 °F)

Wiring

Wires	Color	Pin	M12 A-coded female connector (5 pin)
	BN	↔ 1	
	WH	↔ 2	
	BU	↔ 3	
	BK	↔ 4	
	GY	↔ 5	



**Cable with M12 A-coded female
connector (5 pin), angled – pigtail**
Part no. 370 675

Material: PUR jacket
Features: Shielded
Cable length: 5 m (16.4 ft)
Ingress protection: IP67 (correctly fitted)
Operating temperature:
-25...+80 °C (-13...+176 °F)

Wiring

Wires	Color	Pin	M12 A-coded female connector (5 pin)
	BN	↔ 1	
	WH	↔ 2	
	BU	↔ 3	
	BK	↔ 4	
	GY	↔ 5	

INSTALLATION

Hydraulics sealing

For sealing the flange contact surface, a sealing via an O-ring in the undercut is necessary. A screw hole based on ISO 6149-1 (metric) or SAE J1926-1 (imperial) must be provided.

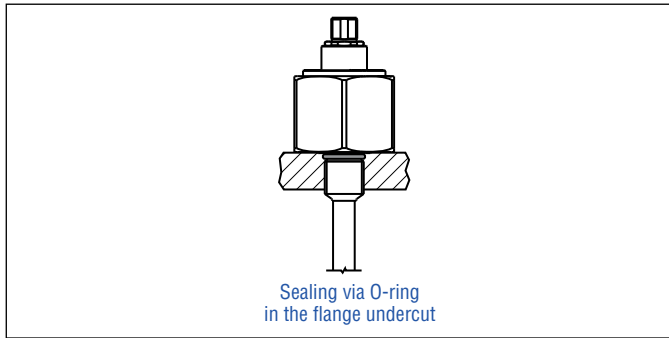
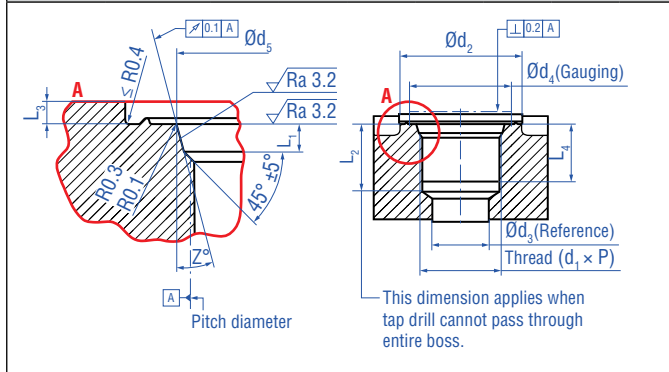

Fig. 12: Sealing via O-ring

Threaded port

Thread (d ₁ × P)	d ₂	d ₃	d ₄	d ₅	L ₁	L ₂	L ₃	L ₄	Z°
M18 × 1.5	55	13	24.5	19.8	2.4	28.5	2	22	15°
¾" - 16 UNF	30	10	22	20.6	2.5	17.5	2.4	14.3	15°



- Note the fastening torque of 50 Nm.
- The flange contact surface must be seated completely on the cylinder mounting surface.
- The cylinder manufacturer determines the pressure-resistant gasket (copper gasket, O-ring, etc.).
- The position magnet should not make contact with the sensor rod.
- The peak pressure should not be exceeded.
- Protect the sensor rod against wear.
- Note the piston rod drilling:
 - Ø 7 mm rod: ≥ Ø 10 mm
 - Ø 10 mm rod: ≥ Ø 13 mm

NOTICE

The bore depth in piston:
Null zone + Stroke length + Dead zone + > 3 mm

MECHANICAL INSTALLATION – POSITION MAGNET

Magnet installation

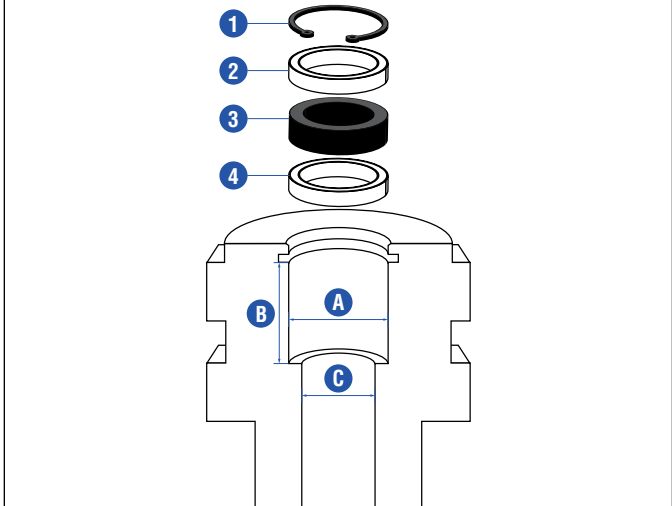

- 1 Circlip
- 2 Non-magnetic spacer
- 3 Position magnet
- 4 Non-magnetic spacer (≥ 5 mm)

Position magnet (Part no.)

	401 032	400 533	201 542-2
A	17.4 mm	25.4 mm	32.8 mm
B	≥ 18 mm	≥ 18 mm	≥ 18 mm
C	Rod Ø 7 mm →	Piston rod drilling ≥ Ø 10 mm	
	Rod Ø 10 mm →	Piston rod drilling ≥ Ø 13 mm	

Fig. 13: Dimensions for magnet mounting

MECHANICAL INSTALLATION – FLOAT

Float installation

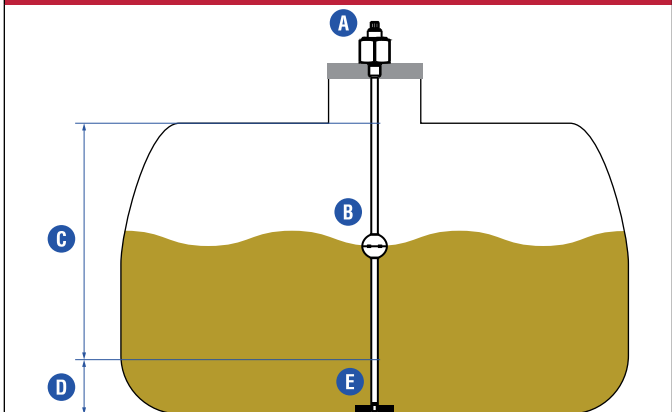

- A MH threaded sensor
- B Float
- C Stroke length
- D Dead zone
- E Stop collar

Fig. 14: Dimensions for float mounting

ORDER CODE

1	2	3	4	5	6	7	8	9	10	11	12	13	14	15	16	17	18	19
M	H						M					3						
a		b	c					d				e	f			g	h	

a	Sensor model	
M	H	Threaded flange

b	Design
G	Threaded flange M18×1.5: Rod: Ø 10 mm + end plug with male M8 thread / Dead zone: 55.5 mm / Stroke length: 50...1200 mm
H	Threaded flange M18×1.5: Rod: Ø 7 mm / Dead zone: 63.5 mm / Stroke length: 50...2500 mm
K	Threaded flange M18×1.5: Rod: Ø 10 mm + end plug with female M6 thread / Dead zone: 52.5 mm / Stroke length: 50...1200 mm
N	Threaded flange M18×1.5: Rod: Ø 10 mm / Dead zone: 63.5 mm / Stroke length: 50...2500 mm
P	Threaded flange M18×1.5: Rod: Ø 7 mm / Dead zone: 45.5 mm / Stroke length: 50...1200 mm
T	Threaded flange M18×1.5: Rod: Ø 10 mm / Dead zone: 45.5 mm / Stroke length: 50...1200 mm
W	Threaded flange ¾"-16 UNF: Rod: Ø 10 mm / Dead zone: 63.5 mm / Stroke length: 50...2500 mm

c	Stroke length				
X	X	X	X	M	0050...2500 mm (in 5 mm steps)

d	Electrical wiring				
M12 connector					
M	0	0	F	M12 connector (5 pin)	
Cable outlet					
C	0	3	A	300 mm cable without connector	
C	0	5	A	500 mm cable without connector	
C	1	0	A	1000 mm cable without connector	
C	2	0	A	2000 mm cable without connector	
C	3	0	A	3000 mm cable without connector	
C	5	0	A	5000 mm cable without connector	

e	Operating voltage
3	+12 / 24 VDC (8...32 VDC)

f	Output		
C	0	1	CANopen with cycle time 1 ms (default setting)
J	0	1	SAE J1939 with cycle time 20 ms (default setting)

g	Baud rate
CANopen (C01)	
0	1000 kbit/s
1	800 kbit/s
2	500 kbit/s
3	250 kbit/s (default)
4	125 kbit/s
6	50 kbit/s
SAE J1939 (J01)	
2	500 kbit/s
3	250 kbit/s (default)

h	Node ID (CANopen) / Source address (SAE J1939)
CANopen (C01)	
	Hex 01...7F (default: 7F)
SAE J1939 (J01)	
	Hex 01...FD (default: FD)

DELIVERY



- Position sensor
 - O-ring
- Accessories have to be ordered separately

Manuals, Software & 3D models available at:
www.temposonics.com

UNITED STATES
Temposonics, LLC
Americas & APAC Region
3001 Sheldon Drive
Cary, N.C. 27513
Phone: +1 919 677-0100
E-mail: info.us@temposonics.com

GERMANY
Temposonics
GmbH & Co. KG
EMEA Region & India
Auf dem Schüffel 9
58513 Lüdenscheid
Phone: +49 2351 9587-0
E-mail: info.de@temposonics.com

ITALY
Branch Office
Phone: +39 030 988 3819
E-mail: info.it@temposonics.com

FRANCE
Branch Office
Phone: +33 6 14 060 728
E-mail: info.fr@temposonics.com

UK
Branch Office
Phone: +44 79 21 83 05 86
E-mail: info.uk@temposonics.com

SCANDINAVIA
Branch Office
Phone: + 46 70 29 91 281
E-mail: info.sca@temposonics.com

CHINA
Branch Office
Phone: +86 21 2415 1000 / 2415 1001
E-mail: info.cn@temposonics.com

JAPAN
Branch Office
Phone: +81 3 6416 1063
E-mail: info.jp@temposonics.com

Document Part Number:
552069 Revision A (EN) 06/2020



temposonics.com