



---

L e v e l P l u s ®

**Loop-Powered Level Transmitter  
Model A4  
(Non-network HART® Version)**  
*Ordering Guide and Installation Manual*

**GENERAL INFORMATION**

***Phone/Fax Numbers***

---

**Phone:** 800-457-6620

**Fax:** 800-943-1145

***Shipping Address***

---

**MTS SYSTEMS CORPORATION**

Sensors Division

3001 Sheldon Drive

Cary, North Carolina 27513

***Office Hours***

---

**Mon. - Thurs.:** 7:30 a.m. to 6:00 p.m. EST

**Friday:** 7:30 a.m. to 5:00 p.m. EST

## Table of Contents

<i>Section</i>	<i>Page</i>
<b>1 INTRODUCTION</b>	1
<b>2 PRODUCT DESCRIPTION</b>	2
2.1 Dimensions	3
2.2 A4 Transmitter Specifications	4
2.3 Accuracy	5
2.4 Theory of Operation	5
<b>3 ORDERING GUIDE</b>	6
3.1 Model Number Generation	6
3.2 A4 Model Number Guide	7
3.3 Application Data for A4 Transmitter	8
3.4 Industrial Sensor Well Model Number Guide	9
3.4.1 Industrial Sensor Well Dimensions/Application Data	10
3.5 Sanitary Sensor Well Model Number Guide	11
3.5.1 Sanitary Sensor Well End Plugs	11
3.5.2 Sanitary Sensor Well Dimensions/Application Data	12
<b>4 MOUNTING</b>	13
4.1 Threaded Flange Mounting	13
4.2 Mounting Options for Industrial Sensor Well	14
4.3 Mounting for Sanitary Sensor Well	15
<b>5 ELECTRICAL CONNECTIONS and WIRING PROCEDURES</b>	16
5.1 Hardware Recommendations for HART® Communications	20
5.2 Wiring Procedures	20
5.3 Safety Barriers	22
<b>6 SYSTEM CHECK</b>	23
6.1 Loop #1 Test	23
6.2 Loop #2 Test	23
<b>7 FLOATS</b>	24
<b>8 MAINTENANCE</b>	25
8.1 Transmitter Installation	26
<b>9 ADJUSTMENTS FOR LEVEL PLUS A4 TRANSMITTER (MANUAL)</b>	27
9.1 Alarm Settings	27
9.2 Calibration for A4 Transmitters	27
9.3 Damping Control	28
<b>10 HART® COMMUNICATION</b>	29
10.1 Character Coding	29
10.2 Message Format	30
<i>Table 10-1 Start Character Definition</i>	30
10.3 Using the HART interface	33
10.4 HART Commands	34
<i>Table 10-2 Universal Commands</i>	35
<i>Table 10-3 Common Practice Commands</i>	36
<i>Table 10-4 Status Coding</i>	37
<i>Table 10-5 Command Specific Error Codes</i>	38
<i>Table 10-6 Unit Codes</i>	38
<i>Table 10-7 Analog Output Codes</i>	38
<b>11 ADJUSTMENTS FOR LEVEL PLUS A4 TRANSMITTER (via HART)</b>	39
11.1 HART Quickstart	39
11.2 Damping Adjustment using the HART Communicator 275	41

# 1 INTRODUCTION

---

MTS is recognized as the pioneer, innovator and leader in magnetostrictive sensing. The new Level Plus® A4 loop-powered transmitter design represents a continuation of our on-going effort to provide effective, innovative, and reliable products to the liquid level marketplace.

This manual will provide information about the Level Plus A4 loop-powered transmitter, to include:

- Product Description
- Dimensions
- Theory of Operation
- Wiring/Electrical Connections
- Specifications
- Model Numbers
- Mounting
- Adjustments
- Maintenance
- Non-network HART® Interface

## 2 PRODUCT DESCRIPTION

---

The two-wire Level Plus A4 level sensor is a multifunctional transmitter with dual 4-20 mA loops and HART® (Highway Addressable Remote Transducer) communications. It provides outputs for 2 levels (product and interface) or 1 level and temperature.

The Level Plus A4 transmitter is encased in an explosionproof metal housing. In the standard design, the outer tube, or sensing portion of the device, is constructed of rigid 1/2 in. diameter 316L stainless steel (standard) or 5/8 in. Teflon® outer sleeve over existing rigid 1/2 in. diameter 316L stainless steel.

Optional sensor wells are available for use with A4 transmitters. Sensor wells are 5/8 in. tubes sealed in a secondary containment configuration. The sensor wells are installed over the existing 1/2 in. 316L stainless steel tube (see Figure 2-1). Two types of sensor wells are offered:

**1.) Industrial Sensor Well:**

- Material of Construction: 316L stainless steel or Hastelloy® C-276
- Process Connection: Flange (a selection of sizes and ratings) or 3/4 in. NPT adjustable fitting

**2.) Sanitary Sensor Well:**

- Material of Construction: Polished 316L stainless steel
- Process Connection: Sanitary End Cap fitting (a selection of sizes)

Sensor wells permit the A4 transmitter to be easily removed and/or replaced while the tank is in service and the tank connection/seal remains intact.

A temperature sensing function is included with the A4 design. The temperature output can be wired as an independent 4-20 mA current loop. The temperature sensing device is a Resistive Temperature Detector (RTD) mounted inside the transmitter's outer tube assembly. The RTD is a 1000  $\Omega$  platinum film device, capable of an inherent accuracy of  $\pm 0.5^\circ\text{F}$  ( $0.28^\circ\text{C}$ ).

## 2.1 A4 Transmitter Dimensions

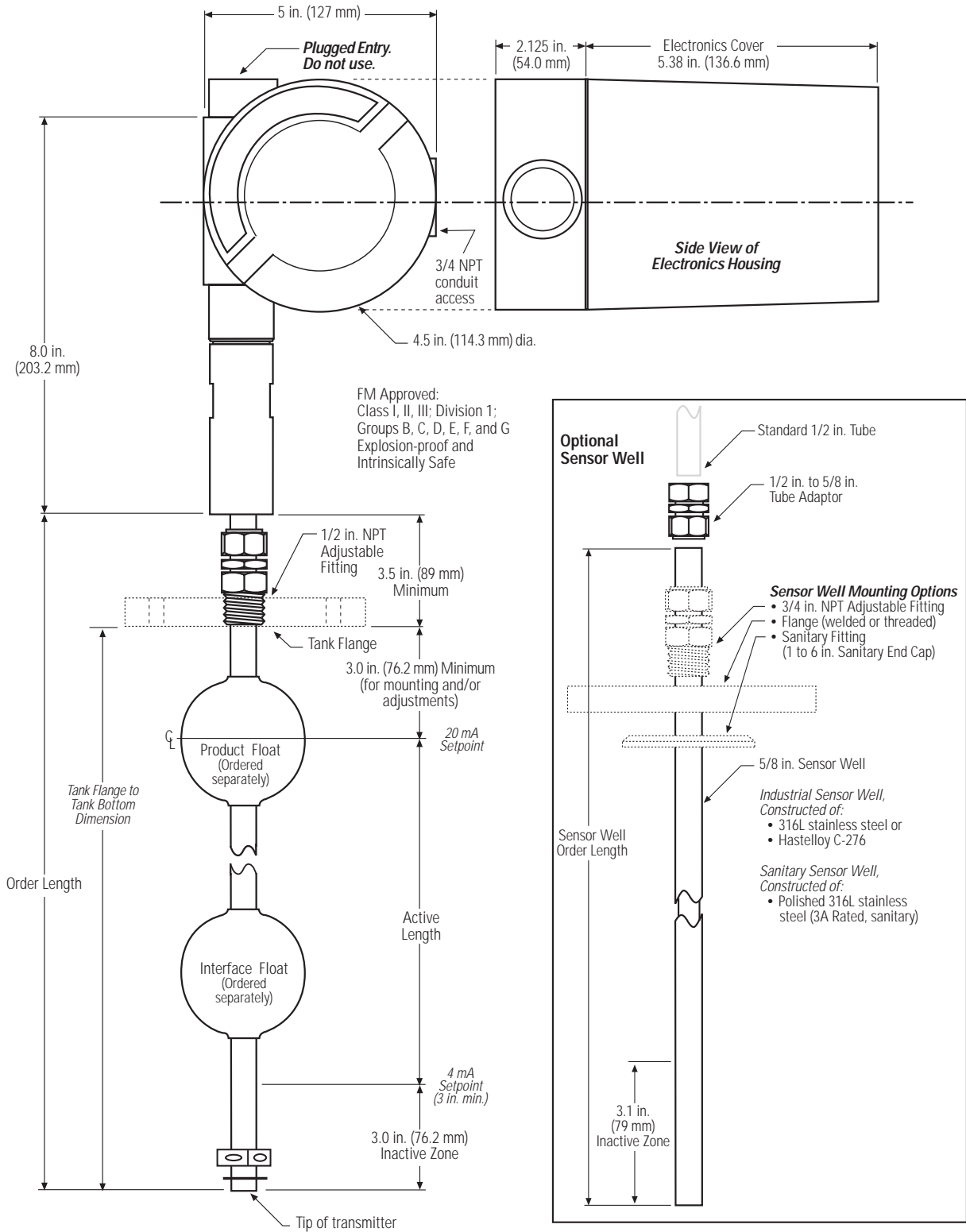

**Figure 2-1**  
**The Level Plus A4 Transmitter**  
**(Typical Configuration)**

## 2.2 A4 Transmitter Specifications

---

### LEVEL OUTPUT

<b>Parameter</b>	<b>Specification</b>
Measured Variable:	Level #1 (typical: product level), Level #2 (typical: interface level) and Temperature
Full Range:	0.5 to 25 ft. (152.4 mm to 7.6 m) less inactive zone (See Figure 2.1)
Non-linearity:	0.035 % F.S. (Independent best straight line) or 1/32 in. (0.794 mm)*
Hysteresis:	0.01 % F.S. or 0.015 in. (0.381 mm)*
Repeatability:	0.01 % F.S. or 0.015 in. (0.381 mm)*
Time Constant:	180 ms (configuration dependent)
Operating Temperature: (for Sensor Tube Only)	-30 to + 300°F (-34 to + 149°C) for transmitter lengths ≤ 220 inches (5588 mm) Contact MTS for operating temperatures for transmitter lengths > 220 inches

### TRANSMITTER LOOP

Input Voltage Range:	10.5 to 36 Vdc
Reverse Polarity Protection:	Series diodes
Safety Approval:	FM approved intrinsically safe for Class I, Division 1, Group C; Class II, Division 1, Groups E, F, and G; Class III, Division 1, with NEMA 4 for outdoor use FM approved explosionproof for Class I, Division 1, Groups B, C, and D; dust ignitionproof for Class II/III Division I, Groups E, F, G hazardous (classified) locations, indoors and outdoors (NEMA Type 4X)

### CALIBRATION

Zero Adjust Range:	Anywhere within the active length
Span Adjust Range:	FS ≥ 0.5 ft. from Zero

### TEMPERATURE OUTPUT

Type:	Resistance Temperature Detector (RTD) 1,000Ω
Interchangeability:	± 0.3°C (0.54°F)
Repeatability:	± 0.1°C (0.18°F)
Accuracy:	± 1.5°C (2.7°F); includes non-linearity, hysteresis, and repeatability
Drift:	± 0.5°C (0.9°F) per year
Zero Adjust:	-40 to 124°C (-40 to 255°F)
Span Adjust:	25°C (45°F) minimum, Full Scale (maximum) = 149°C (300°F)

### ENVIRONMENTAL

Sealing:	Potted sensor cartridge, electronics are conformally-coated
Humidity:	0 to 100 % R.H.
Operating Temperature (Electronics):	-34 to 71°C (-30 to 160°F)
Operating Pressure:	1.896 MPa maximum (275 PSI)
Materials (wetted parts):	316L stainless steel standard, other material available optionally
Minimum Life Expectancy:	10 years

### FIELD INSTALLATION (For local calibration ONLY)

Gauge Length:	2 to 25 ft. (0.6 to 7.6 meters)
Size (electronics enclosure):	Refer to dimension drawing, Fig. 2-1
Mounting (typical):	Standard: 1/2 in. NPT adjustable fitting (3/4 in. NPT, sanitary, or welded flange mounting available with optional sensor well)
Wiring:	2-wire connection, shielded cable or twisted pair to screw terminals through a 3/4 in. NPT conduit opening

### HART COMMUNICATIONS (available for local calibration only)

Method of Communication:	Frequency Shift Keying (FSK) conforms with Bell 202 Modem Standard with respect to baud rate and digital "1" and "0" frequencies.
Baud Rate:	1200 bps.
Digital "0" Frequency:	2200 Hz.
Digital "1" Frequency:	1200 Hz.
Data Byte Structure:	1 Start Bit, 8 Data Bits, 1 Odd Parity Bit, 1 Stop Bit
Digital Process Variable Rate:	Poll/Response Model 2.0 per second

All specifications are subject to change without notice. Consult MTS for verification of specifications critical to your needs.

\* Whichever is greater

### 2.3 Accuracy

---

The absolute accuracy of the transmitter is a function of the manufacture of the waveguide. That is, any imperfections in the waveguide are reflected in the linearity of its output. The tolerances reflect a non-linearity of 0.035% full scale. Due to its high degree of repeatability, the differential accuracy is extremely high.

### 2.4 Theory of Operation

---

The magnetostrictive Level Plus transmitters precisely sense the position of an external float by applying a short (1.5  $\mu$ s) interrogation pulse to a waveguide medium. This current pulse causes a magnetic field to instantly surround the waveguide. The magnet installed within the float also creates a magnetic field. Where the magnetic fields from the waveguide and float intersect, a rotational force is created (waveguide twist). This, in turn, creates a torsional sonic pulse that travels along the waveguide (Refer to Figure 2-2).

The head of the transmitter houses the sensing circuit, which detects the torsional sonic pulse and converts it to an electrical pulse. The distance from a reference point to the float is determined by measuring the time interval between the initiating current pulse and the return pulse and precisely knowing the speed of these pulses. The time interval is converted into a 4 - 20 mA loop signal.

The Level Plus A4 transmitter offers level #1, level #2, and temperature. There are two current loops available: level #1 is always assigned to loop 1, either level #2 or temperature is assigned to loop 2.

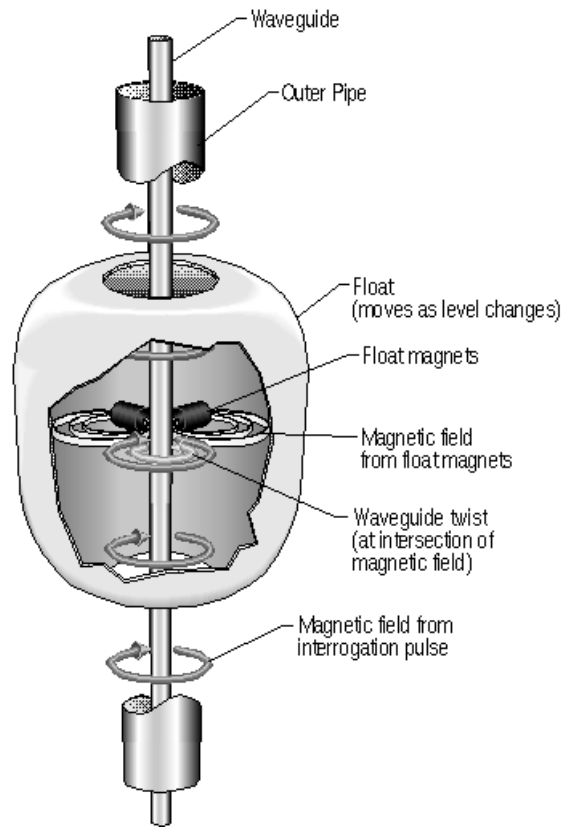

**Figure 2-2**  
**Principle of Magnetostriction**



## 3 ORDERING GUIDE

---

### 3.1 Model Number Generation

---

The following information describes the six fields in the Level Plus A4 transmitter model number guide (see Section 3.2). The model number describes the features of each A4 transmitter. This number is required when placing an order or when contacting MTS with questions regarding the transmitter after the devices are shipped to you.

At the time of order, in addition to the model number, you must also complete an Application Data Sheet (see Section 3.3). The Application Data Sheet asks questions about your specific application and helps us to determine the best solution to your application demands.

#### 1 - MODEL:

**A4** = Multifunctional transmitter, dual 4-20 mA loop w/HART

Output Options:

- 2 levels (product and interface), or
- 1 level and 1 temperature

#### 2 - UNIT OF MEASURE:

The “Unit of Measure” is a single digit code which identifies the engineering units in which you want to express the length of the transmitter. It also selects the units used for the data output via HART.

*Selection:*

- 1** = For length: Inches and tenths (xxx.x in.); For temperature: °F
- 2** = For length: Millimeters (xxxx mm); For temperature: °C

#### 3 - LENGTH:

The length of the transmitter is defined in Figure 2-1. Normal installation requirements dictate that the desired transmitter length for a vessel should be measured from the bottom of the vessel to the top of the vessel flange, plus 5 inches. This additional 5 inches allows for various mounting configurations for above ground storage tanks. The transmitter length should be accurately measured prior to ordering. Vessel or tank flexure that occurs during filling, the amount of adjustment available at the top of the vessel, and changes due to temperature fluctuations should be considered when defining the desired length. Encode the length in the model number using a 4-digit code.

Standard A4 transmitters are available in lengths from 24 inches (encode 0240) to 300 inches (encode 3000) in 12 inch increments or from 610 millimeters (encode 0610) to 7620 millimeters (encode 7620). Custom lengths are also available (price adders and extended lead times apply).

#### 4 - WETTED PARTS:

The standard wetted parts are constructed of 316L stainless steel. Wetted parts include the adjustable fitting and the tube as illustrated in Fig. 2-1. Sensor wells and flanges are available separately. Sensor wells can be constructed of optional materials to meet your application demands:

*Selection:*

- 0** = Standard, 316L stainless steel (1/2 in. NPT and tube)
- 1** = Optional mounting configurations and pipe materials (sensor well required)
- 2** = Teflon



### 3.3 Application Data for A4 Transmitters

The following information must be provided at the time of order to ensure that your application requirements are met.

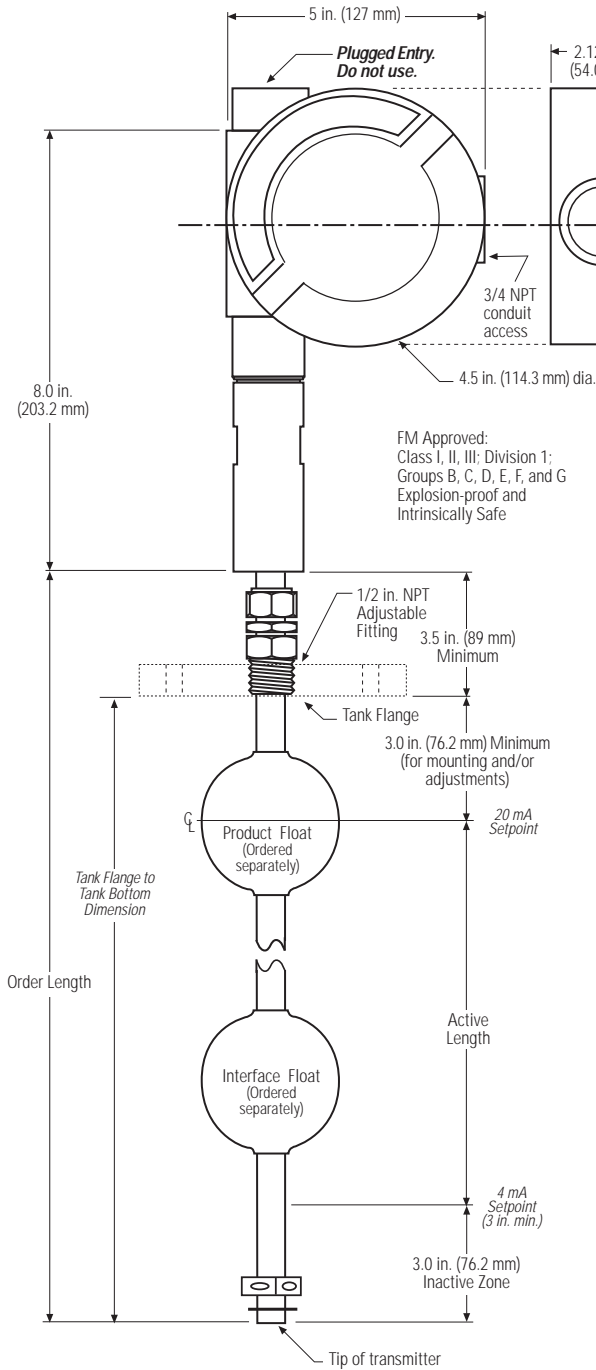

**Figure 3-1**  
**Level Plus A4 Transmitter**

MTS Quote/Order #:	
Company Name:	
Customer Reference #:	
Model #:	Quantity:
Order Length:	
Sensor Pipe Material:	
Flange/Process Connection: <b>1/2 in. NPT Male Fitting (included)</b>	
Product Float P/N:	
Product Float Material:	
Product Specific Gravity:	
Interface Float P/N:	
Interface Float Material:	
Interface Specific Gravity:	
Signal Output: <b>4-20 mA</b>	
4 mA Location, <b>Loop 1:</b>	<b>Loop 2:</b>
20 mA Location, <b>Loop 1:</b>	<b>Loop 2:</b>
Power Supply Required: <b>24 Vdc</b>	
Maximum Vessel Operating Pressure: <b>275 PSI</b>	
Maximum Vessel Operating Temperature Range:	
<b>Check One:</b>	
<b>Market Description Code</b>	<b>Market Description Code</b>
<input type="checkbox"/> FB Food and Beverage	<input type="checkbox"/> PR Petroleum Production
<input type="checkbox"/> CH General Chemicals	<input type="checkbox"/> RE Petroleum Refining
<input type="checkbox"/> HP High Value Petrochemicals	<input type="checkbox"/> PB Pharmaceutical/Biotech
<input type="checkbox"/> LP LPG/LNG	<input type="checkbox"/> SG Sight Glass
<input type="checkbox"/> PE Petrochemical	<input type="checkbox"/> SV Solvents
<input type="checkbox"/> MA Petroleum Marketing	<input type="checkbox"/> TR Transportation
<input type="checkbox"/> PL Petroleum Pipeline	<input type="checkbox"/> US Ultrapure chemicals/Semiconductor
Customer Signature: _____ Date: _____	
Phone Number: _____	
MTS Acceptance: _____ Date: _____	

### 3.4 Industrial Sensor Well Model Number Guide

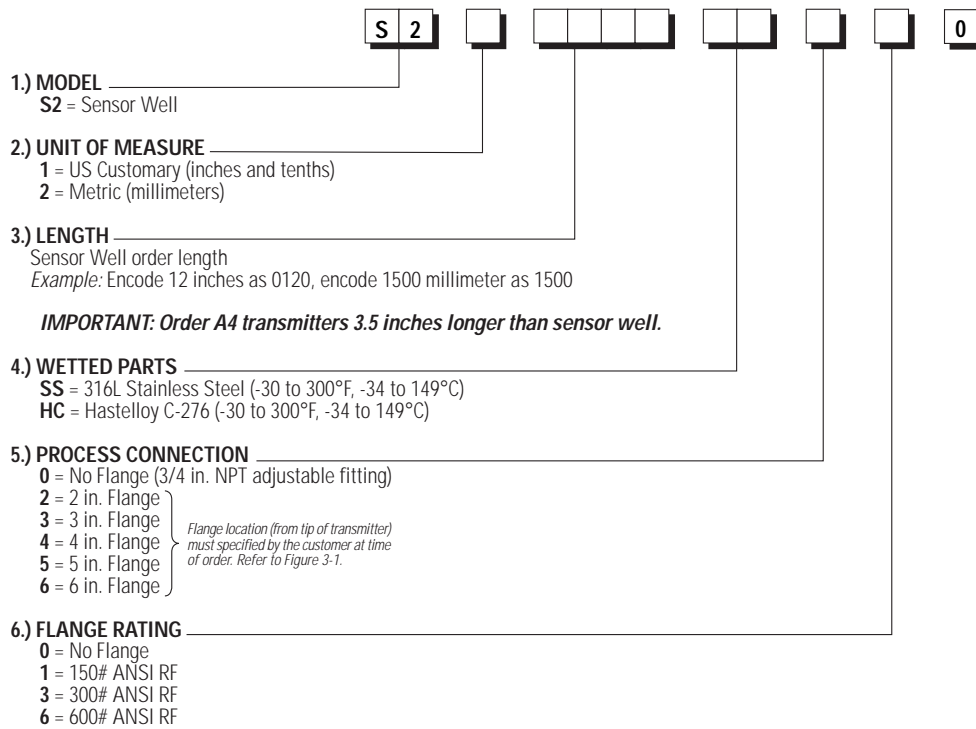

### 3.4.1 Industrial Sensor Well Dimensions/Application Data

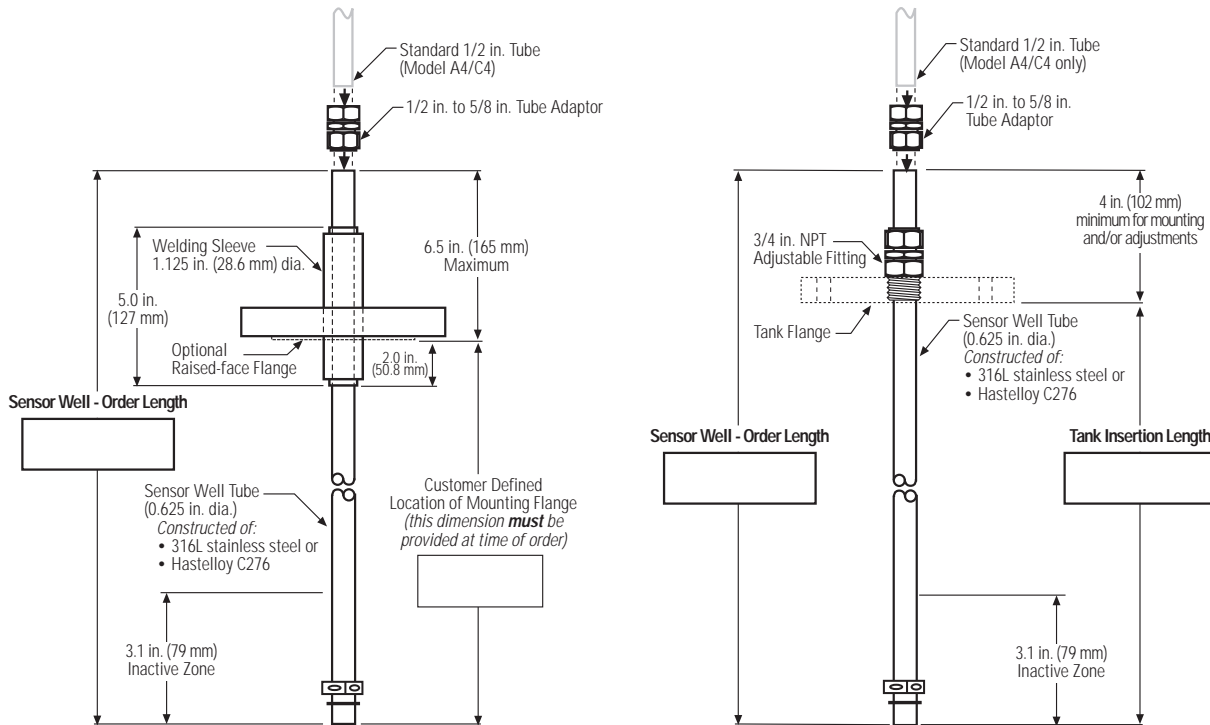

**Figure 3-2**  
**Industrial Sensor Well**  
*(Left, welded flange; right, adjustable fitting)*

APPLICATION DATA SHEET	SENSOR WELL 2																
MTS Quote/Order #: _____	Material of Construction: _____																
Company Name: _____	Total Length: _____																
Customer Reference #: _____	Process Connection: _____																
Model #: _____ Quantity: _____	Location of Mounting Flange (if required): _____ inches from tip																
Product Float P/N: _____	Flange Size: _____																
Product Float Dimensions: _____	Flange Rating: _____																
Product Specific Gravity: _____	<b>Check One:</b>																
Interface Float P/N: _____	<table style="width: 100%; border: none;"> <tr> <td style="width: 50%;"><b>Market Description Code</b></td> <td style="width: 50%;"><b>Market Description Code</b></td> </tr> <tr> <td><input type="checkbox"/> FB Food and Beverage</td> <td><input type="checkbox"/> PR Petroleum Production</td> </tr> <tr> <td><input type="checkbox"/> CH General Chemicals</td> <td><input type="checkbox"/> RE Petroleum Refining</td> </tr> <tr> <td><input type="checkbox"/> HP High Value Petrochemicals</td> <td><input type="checkbox"/> PB Pharmaceutical/Biotech</td> </tr> <tr> <td><input type="checkbox"/> LP LPG/LNG</td> <td><input type="checkbox"/> SG Sight Glass</td> </tr> <tr> <td><input type="checkbox"/> PE Petrochemical</td> <td><input type="checkbox"/> SV Solvents</td> </tr> <tr> <td><input type="checkbox"/> MA Petroleum Marketing</td> <td><input type="checkbox"/> TR Transportation</td> </tr> <tr> <td><input type="checkbox"/> PL Petroleum Pipeline</td> <td><input type="checkbox"/> US Ultrapure chemicals/Semiconductor</td> </tr> </table>	<b>Market Description Code</b>	<b>Market Description Code</b>	<input type="checkbox"/> FB Food and Beverage	<input type="checkbox"/> PR Petroleum Production	<input type="checkbox"/> CH General Chemicals	<input type="checkbox"/> RE Petroleum Refining	<input type="checkbox"/> HP High Value Petrochemicals	<input type="checkbox"/> PB Pharmaceutical/Biotech	<input type="checkbox"/> LP LPG/LNG	<input type="checkbox"/> SG Sight Glass	<input type="checkbox"/> PE Petrochemical	<input type="checkbox"/> SV Solvents	<input type="checkbox"/> MA Petroleum Marketing	<input type="checkbox"/> TR Transportation	<input type="checkbox"/> PL Petroleum Pipeline	<input type="checkbox"/> US Ultrapure chemicals/Semiconductor
<b>Market Description Code</b>	<b>Market Description Code</b>																
<input type="checkbox"/> FB Food and Beverage	<input type="checkbox"/> PR Petroleum Production																
<input type="checkbox"/> CH General Chemicals	<input type="checkbox"/> RE Petroleum Refining																
<input type="checkbox"/> HP High Value Petrochemicals	<input type="checkbox"/> PB Pharmaceutical/Biotech																
<input type="checkbox"/> LP LPG/LNG	<input type="checkbox"/> SG Sight Glass																
<input type="checkbox"/> PE Petrochemical	<input type="checkbox"/> SV Solvents																
<input type="checkbox"/> MA Petroleum Marketing	<input type="checkbox"/> TR Transportation																
<input type="checkbox"/> PL Petroleum Pipeline	<input type="checkbox"/> US Ultrapure chemicals/Semiconductor																
Interface Float Dimensions: _____	<b>Customer Signature:</b> _____ <b>Date:</b> _____																
Interface Specific Gravity: _____	<b>Phone Number:</b> _____																
Sensor Tube Material: _____	<b>MTS Acceptance:</b> _____ <b>Date:</b> _____																
Flange/Process Connection: _____																	
Maximum Vessel Operating Pressure: <b>6.894 MPa, 1000 PSI</b>																	
Maximum Operating Temperature Range: <b>-30 to 300°F (-34 to 149°C)</b>																	

### 3.5 Sanitary Sensor Well Model Number Guide

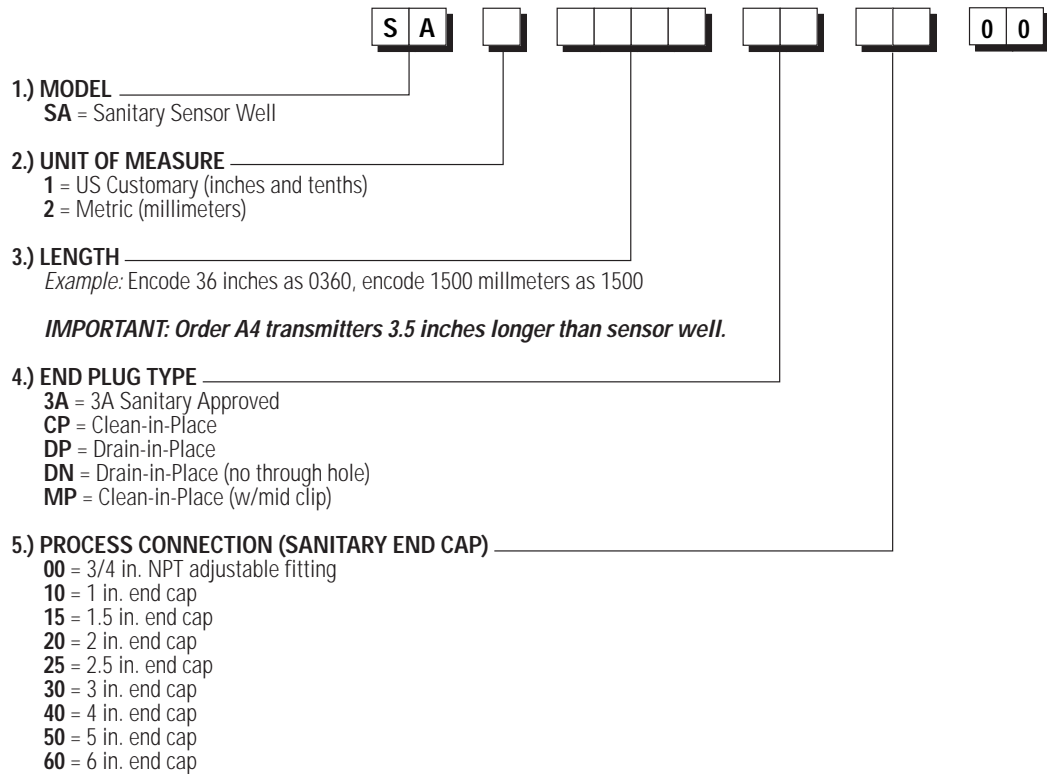

#### 3.5.1 Sanitary Sensor Well End Plugs

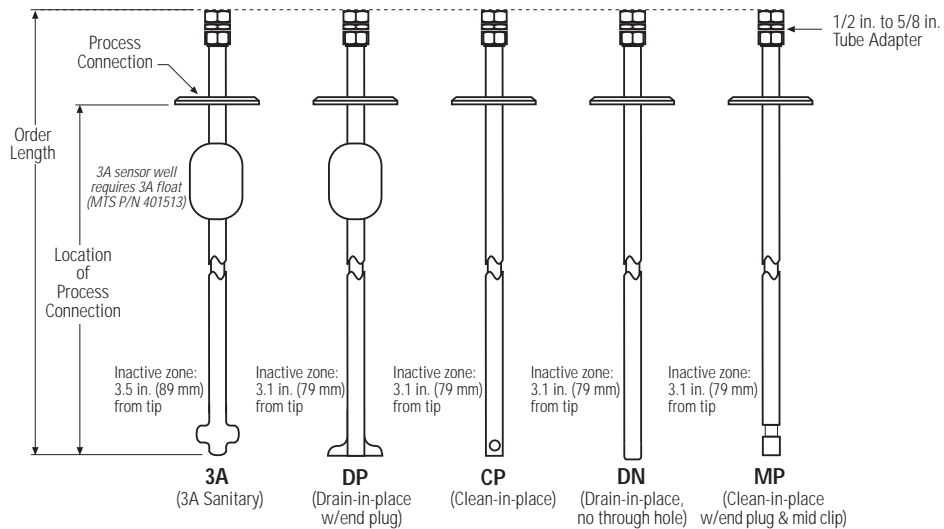

**NOTES:**

- 1.) Sensor wells with "3A" and "DP" end plugs have permanently mounted floats—floats cannot be removed from pipe.
- 2.) Sensor wells with "CP" and "MP" end plugs use a hitch-pin for float retention.
- 3.) Sensor wells with a "DN" end plug have no float retention mechanism.
- 4.) Float P/N 401513 is recommended for use with all Sanitary Sensor Wells as other floats may enter the inactive zone when the tank is emptied.

**Figure 3-3**  
**Tubing Configurations**

### 3.5.2 Sanitary Sensor Well Dimensions/Application Data

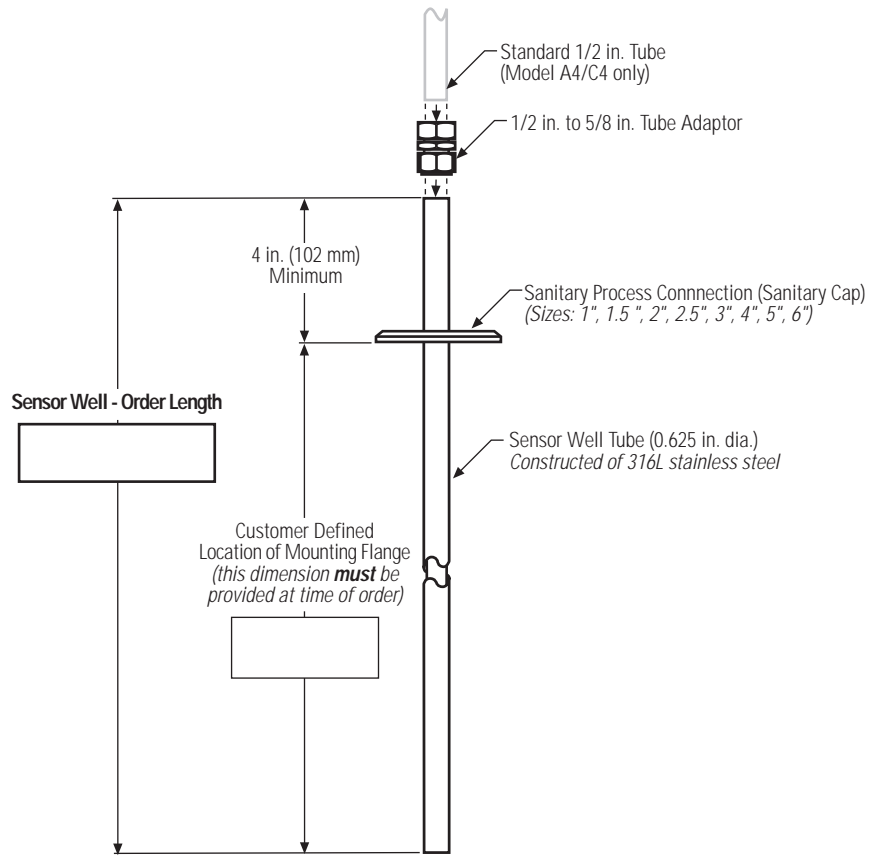

**Figure 3-4  
Sanitary Sensor Well**

APPLICATION DATA SHEET	SANITARY SENSOR WELL 2 (if required)																
MTS Quote/Order #: _____	Material of Construction: <b><i>Polished 316L SS, 200 Grit/25 RA Sanitary Finish</i></b>																
Company Name: _____	Total Length: _____																
Customer Reference #: _____	End Plug Type: _____																
Model #: _____ Quantity: _____	Process Connection (Sanitary Cap Size): _____																
Product Float P/N: _____	Location of Sanitary Cap: _____ inches from tip																
Product Float Dimensions: _____	<b>Check One:</b>																
Product Specific Gravity: _____	<table style="width: 100%; border: none;"> <thead> <tr> <th style="text-align: left; padding: 2px;"><b><i>Market Description Code</i></b></th> <th style="text-align: left; padding: 2px;"><b><i>Market Description Code</i></b></th> </tr> </thead> <tbody> <tr> <td style="padding: 2px;"><input type="checkbox"/> FB Food and Beverage</td> <td style="padding: 2px;"><input type="checkbox"/> PR Petroleum Production</td> </tr> <tr> <td style="padding: 2px;"><input type="checkbox"/> CH General Chemicals</td> <td style="padding: 2px;"><input type="checkbox"/> RE Petroleum Refining</td> </tr> <tr> <td style="padding: 2px;"><input type="checkbox"/> HP High Value Petrochemicals</td> <td style="padding: 2px;"><input type="checkbox"/> PB Pharmaceutical/Biotech</td> </tr> <tr> <td style="padding: 2px;"><input type="checkbox"/> LP LPG/LNG</td> <td style="padding: 2px;"><input type="checkbox"/> SG Sight Glass</td> </tr> <tr> <td style="padding: 2px;"><input type="checkbox"/> PE Petrochemical</td> <td style="padding: 2px;"><input type="checkbox"/> SV Solvents</td> </tr> <tr> <td style="padding: 2px;"><input type="checkbox"/> MA Petroleum Marketing</td> <td style="padding: 2px;"><input type="checkbox"/> TR Transportation</td> </tr> <tr> <td style="padding: 2px;"><input type="checkbox"/> PL Petroleum Pipeline</td> <td style="padding: 2px;"><input type="checkbox"/> US Ultrapure chemicals/Semiconductor</td> </tr> </tbody> </table>	<b><i>Market Description Code</i></b>	<b><i>Market Description Code</i></b>	<input type="checkbox"/> FB Food and Beverage	<input type="checkbox"/> PR Petroleum Production	<input type="checkbox"/> CH General Chemicals	<input type="checkbox"/> RE Petroleum Refining	<input type="checkbox"/> HP High Value Petrochemicals	<input type="checkbox"/> PB Pharmaceutical/Biotech	<input type="checkbox"/> LP LPG/LNG	<input type="checkbox"/> SG Sight Glass	<input type="checkbox"/> PE Petrochemical	<input type="checkbox"/> SV Solvents	<input type="checkbox"/> MA Petroleum Marketing	<input type="checkbox"/> TR Transportation	<input type="checkbox"/> PL Petroleum Pipeline	<input type="checkbox"/> US Ultrapure chemicals/Semiconductor
<b><i>Market Description Code</i></b>	<b><i>Market Description Code</i></b>																
<input type="checkbox"/> FB Food and Beverage	<input type="checkbox"/> PR Petroleum Production																
<input type="checkbox"/> CH General Chemicals	<input type="checkbox"/> RE Petroleum Refining																
<input type="checkbox"/> HP High Value Petrochemicals	<input type="checkbox"/> PB Pharmaceutical/Biotech																
<input type="checkbox"/> LP LPG/LNG	<input type="checkbox"/> SG Sight Glass																
<input type="checkbox"/> PE Petrochemical	<input type="checkbox"/> SV Solvents																
<input type="checkbox"/> MA Petroleum Marketing	<input type="checkbox"/> TR Transportation																
<input type="checkbox"/> PL Petroleum Pipeline	<input type="checkbox"/> US Ultrapure chemicals/Semiconductor																
Interface Float P/N: _____	Customer Signature: _____ Date: _____																
Interface Float Dimensions: _____	Phone Number: _____																
Interface Specific Gravity: _____	MTS Acceptance: _____ Date: _____																
Sensor Tube Material: _____																	
Flange/Process Connection: _____																	
Maximum Vessel Operating Pressure: <b><i>6.894 MPa, 275 PSI</i></b>																	
Maximum Operating Temperature Range: <b><i>-30 to 300°F (-34 to 149°C)</i></b>																	

## 4 MOUNTING

The method of mounting the Level Plus A4 transmitter is dependent on the vessel or tank in which it is being used. Most applications will require one of two methods: threaded or flange mounting.

### 4.1 Threaded Flange Mounting

The A4 transmitter can also be mounted in a blind flange that has been drilled and tapped (see Fig. 4.1). First, remove the float(s) from the transmitter. Second, mount the transmitter in the threaded flange opening (1/2 in. NPT). Third, remount the float on the transmitter. Then, to complete the installation, mount the transmitter and flange as a unit onto the tank. In general, there must not be more than 12 inches of the transmitter's rod extending above the vessel.

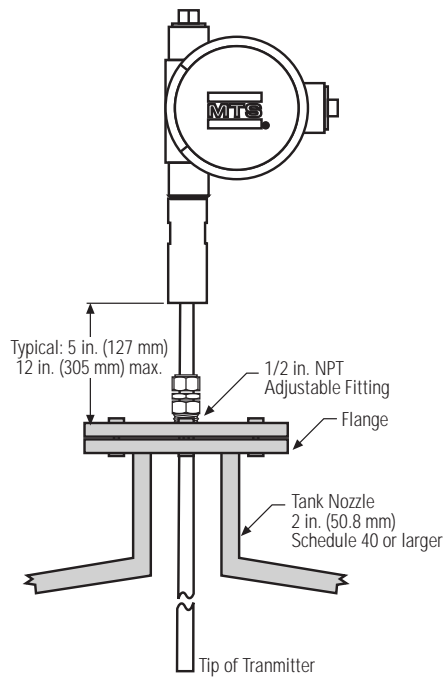

**Figure 4-1**  
**Threaded Flange Mounting**



## 4.2 Mounting Options for Industrial Sensor Well

### 4.2a Threaded Flange Mounting

In applications with smaller vessels and tanks, the industrial sensor well can be mounted directly to the tank via a 3/4 in. NPT fitting, assuming there is a proper threaded connection. There must also be some means to mount the float on the transmitter from inside the vessel; this will require an access port nearby the entry point of the transmitter (see Figure 4-2a).

First, the float(s) is removed from the transmitter by removing the collar and E-Clip. The tip of the transmitter is inserted through the threaded vessel opening. Before completely inserting the transmitter to the bottom of the vessel, you must remount the float(s) through an access port and also reattach the float retaining collar and E-Clip.

The tip of the transmitter rod can now be lowered to the vessel bottom and the threaded 3/4 in. NPT vessel connection can be made. In general, there must not be more than 12 inches of the transmitter's rod extending above the vessel.

### 4.2b Welded Flange Mounting

The industrial sensor well can also be mounted to a tank flange (see Fig. 4-2b). First, install the float(s) onto the transmitter. Second, install a float-retaining device on the tip of the sensor well. To complete the installation, mount the transmitter, flange and float(s) as a unit in to the tank. In general, there must not be more than 12 inches of the transmitter's rod extending above the vessel.

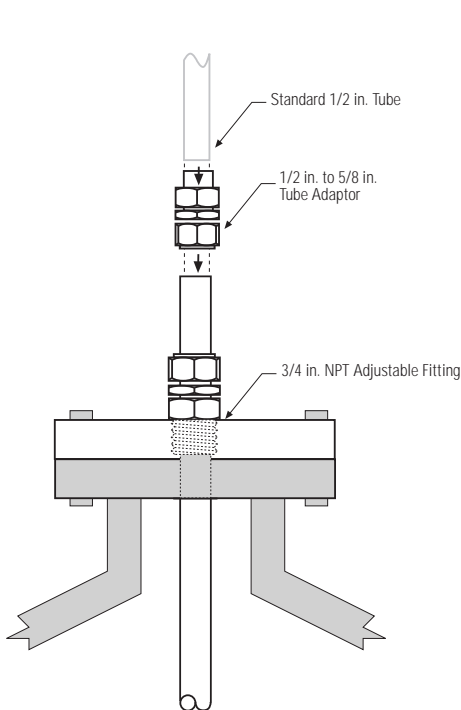

**Figure 4-2a**  
**Threaded Flange Mounting**

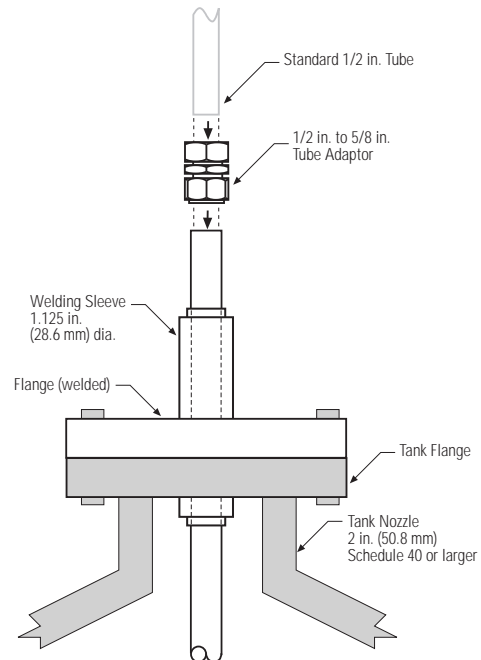

**Figure 4-2b**  
**Welded Flange Mounting**

## 4.3 Mounting for Sanitary Sensor Well

### 4.3a Sanitary Fitting

In sanitary applications the A4 transmitter is mounted to the tank via a sanitary sensor well. These sanitary sensor wells offer secondary containment and allow the A4 transmitter to be easily removed and/or replaced with the tank in service and the vessel seal intact.

Installation is via a standard sanitary end cap fitting and clamp. In most cases it is not necessary to remove the float as the sanitary end cap fitting is sized to allow installation with the float in place. Please note that some sanitary end cap styles have the float(s) permanently mounted.

Once the sanitary sensor well is installed the A4 transmitter is lowered into the sensor well until it bottoms out. The 1/2 in. to 5/8 in. tubing adapter is then tightened in order to prevent turning or slippage of the gauge in the well, being careful not to over-tighten the fitting. In general, there must not be more than 12 inches of the transmitter's rod extending above the vessel.

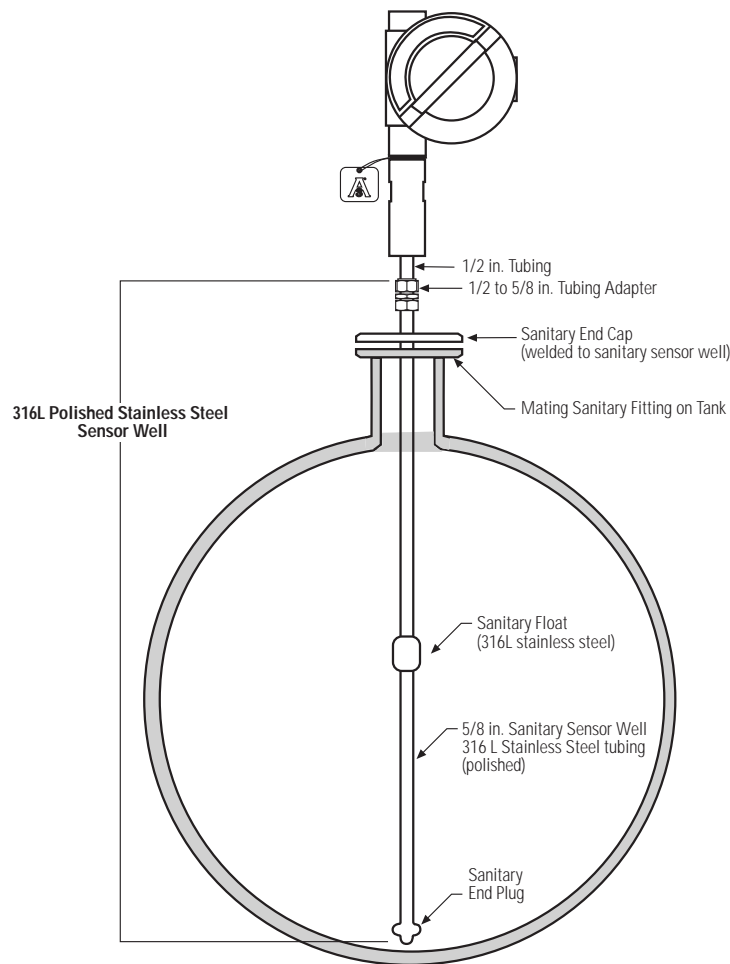

**Figure 4-3**  
**Sanitary Connection**

## 5 ELECTRICAL CONNECTIONS AND WIRING PROCEDURES

---

A typical intrinsically safe connection for the Level Plus transmitters includes protective safety barriers, a power supply, and a reading or monitoring device. Refer to MTS drawing number 650749 on the following pages.

A typical explosionproof connection for the Level Plus transmitters includes a power supply and a reading or monitoring device. Refer to MTS drawing number 650764 on the following pages.

**NOTES:**

*Loop #1 must be powered for the A4 transmitter to operate properly.*

*For explosionproof installation, safety barriers are not required and wiring shall be installed in accordance with the National Electric Code ANSI/NFPA 70, Article 501-30.*





MTS drawing number 650764

## 5.1 Hardware Recommendations for HART Communications

---

<i>Parameter</i>	<i>Specification</i>
Minimum Cable Size:	24 AWG or heavier (0.51 mm diameter) <i>Contact MTS for additional assistance in selecting proper cable</i>
Cable Type:	Single pair shielded or multiple pair with overall shield
Maximum Cable Length:	Twisted Pair: 10,000 ft. (3,048 m) Multiple Twisted-Pair: 5,000 ft. (1,524 m)
Cable Length Formula:	Use the following formula to determine cable length for a specific application:

$$L = [(65 \times 10^6) \div (R \times C)] - [(C_f + 10,000) \div C]$$

*Where:*

L = Length in feet or meters

R = Resistance in ohms, current sense resistance plus barrier resistance

C = Cable capacitance in pF/ft, or pF/m

C<sub>f</sub> = Maximum shunt capacitance of smart field devices in pF

*Example:*

Assume a high performing smart transmitter, a control system, and a single pair of shielded wires.

R = 250 ohms

C = 50 pF/ft

C<sub>f</sub> = 5,000 pF

$$L = [(65 \times 10^6) \div 250 \times 50] - [(5,000 + 10,000) \div 50]$$

$$L = 4,900 \text{ ft (1,494 m)}$$

---

## 5.2 Wiring Procedures

---

Always follow applicable local and national electrical codes and observe polarity when making electrical connections. Never make electrical connections to the A4 transmitter with power turned on. Make sure that no wire strands are loose or sticking out of the terminal block connection which could short and cause a problem. Make sure that no wire strands, including shield, are in contact with the electronic module enclosure. The electronic module enclosure is grounded through internal circuitry and electrically isolated from the explosionproof enclosure.

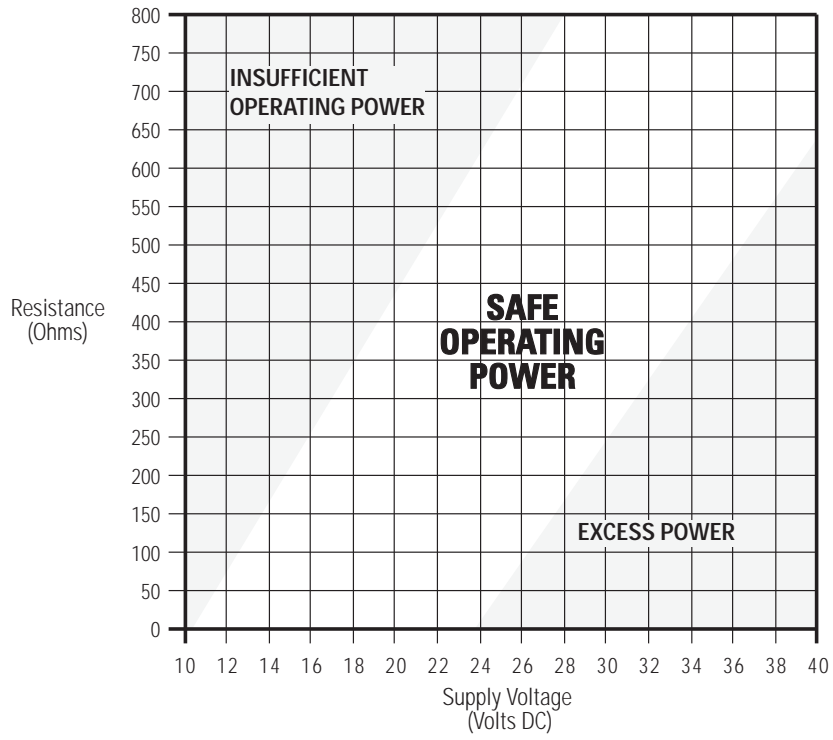

**Figure 5-2**  
**Loop Resistance vs. Power Supply**



### 5.3 Safety Barriers

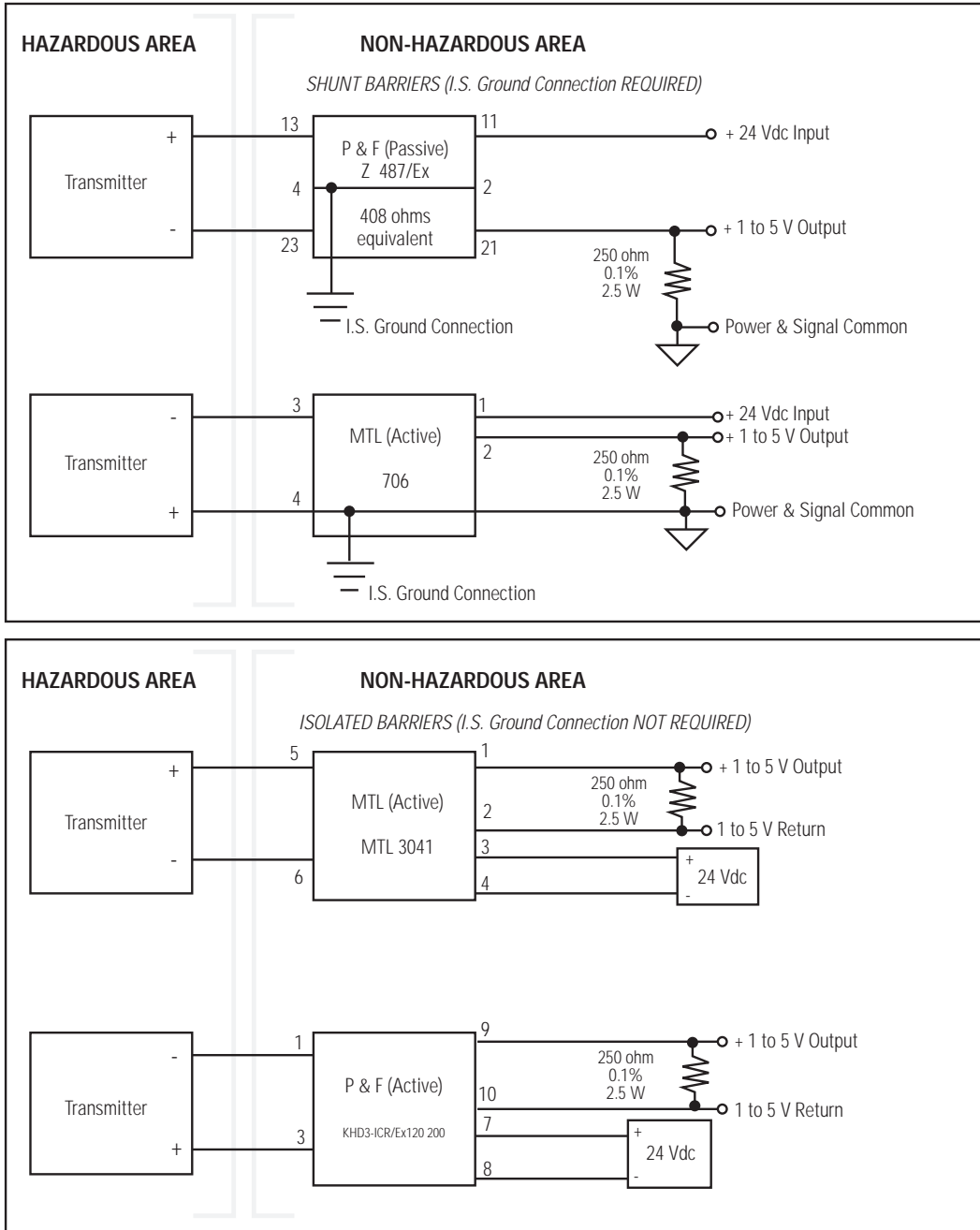

**NOTES:**

- When selecting barrier types, the entity parameters for the A4 transmitter are:  
 $V_{max} = 36.1 \text{ Vdc}$ ,  $I_{max} = 118 \text{ mA}$  (total current),  $C_i = 0.0 \mu\text{F}$ ,  $L_i = 0.0 \mu\text{H}$
- P&F - Pepperl and Fuchs (Phone: 216-425-3555); MTL = MTL Incorporated (Phone: 703-361-0111)

**Figure 5-3**  
**Suggested Safety Barrier Types for A4 Transmitter**

## 6 SYSTEM CHECK

---

After completing the A4 wiring, the system is ready to be checked out. Apply power to the unit. Using a DC volt meter, measure the voltage at loop #1 connections. The voltage must be  $\geq 10.5V$ . If loop #2 is being used, measure the voltage at the loop #2 connections, it also must be at  $\geq 10.5V$ . If the voltage levels are too low, shut down the system. Check for shorts, power supply voltage, and excessive loop resistance. Refer to the Safe Operating Power chart (Fig. 5-2) which shows the relationship between loop resistance and operating voltage.

### 6.1 Loop #1 Test

---

To test loop #1 on a bench, move the float along the operational range of the A4 transmitter. If functioning properly, the output current will change as the float moves.

Testing to see if the output current corresponds to the approximate level in the tank or vessel by moving the float along the operational range of the transmitter is not practical if the A4 is installed in a tank or vessel. An output current of less than 4 mA or greater than 20 mA would indicate a problem with the A4 transmitter—the problem may be with either the sensing element of the transmitter or the float.

### 6.2 Loop #2 Test

---

Disregard this test if you are not using loop #2.

The test varies depending on the configuration:

- Loop # 1 must be powered to access loop #2.
- If loop #2 is set for level measurement, test the transmitter in the same manner as defined in section 6.1, above.
- If loop #2 is assigned to measure temperature, first read the output current. Then, if the setpoint values are known, calculate the temperature using the following formula:

$$T = [(T_{20mA} - T_{4mA}) \div 16] (I - 4) + T_{4mA}$$

**Where:**

T = Temperature

$T_{20mA}$  = Temperature @ 20 mA setpoint (Factory Setting: 300°F)

$T_{4mA}$  = Temperature @ 4 mA setpoint (Factory Setting: -30°F)

I = Output current (in mA)

The A4 transmitter's sensing RTD is located at approximately two inches from the tip of the transmitter. Measure the temperature near the tip to see if it is an approximation of the calculated value. If the output current is less than 4 mA or greater than 20 mA, there may be a problem with the RTD device (i.e., it may be shorted or open).

## 7 FLOATS

---

For information on floats, please refer to the Float Specification document, MTS part number 550537. For float application information please contact the MTS Level Plus Applications Department.

## 8 MAINTENANCE

The Level Plus A4 transmitter design is modular in nature. The electronics module can be replaced in the field without on-site support of the MTS service department.

Replace the 4-20 mA transmitter modules as follows (see Figure 8-1).

**CAUTION!**

*Ensure that all power is disconnected before making any electrical connections.*

1. Remove any dirt, debris, or liquid from the top of the electronics enclosure.
2. Remove the electronics housing cover by rotating the cover counterclockwise.
3. Remove the existing transmitter module by loosening the two screws. Slide the base of the module assembly out.
4. Lift out the module assembly from the housing and disengage the electrical connections.
5. Make the appropriate electrical connections to the new transmitter module before installing it in the housing (see figures below). Make sure all electrical connections are securely tightened.
6. Install the new 4-20 mA transmitter module in the housing by aligning the slots on the module base with 2 screws in mounting area.
7. Slide the module assembly until the screws are positioned at the counterbores in the slot, then tighten the screws.
8. As necessary, recalibrate zero and span points.

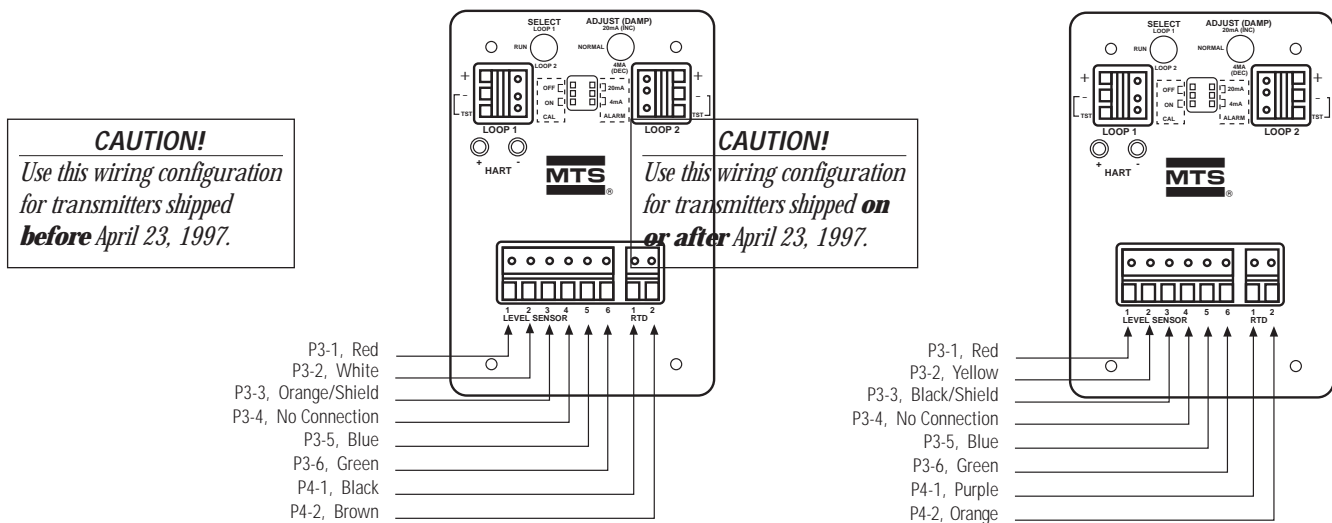

**Figure 8-1**  
**Transmitter Module (Cover removed)**

**CAUTION!**

*Any grounding of the transmitter module will cause the unit to fail. In the event the transmitter is grounded, isolate the transmitter module and retest.*

## 8.1 Transmitter Installation

### NOTES:

- Use an explosionproof type conduit sealing fitting.
- Tighten housing cover to full stop against "O" ring.
- Do not over-tighten compression fittings.
- Use side conduit entry only.
- Do not use plugged housing entry for termination of conduit.
- In high humidity areas, use a breather drain type conduit sealing fitting to minimize moisture intrusion.

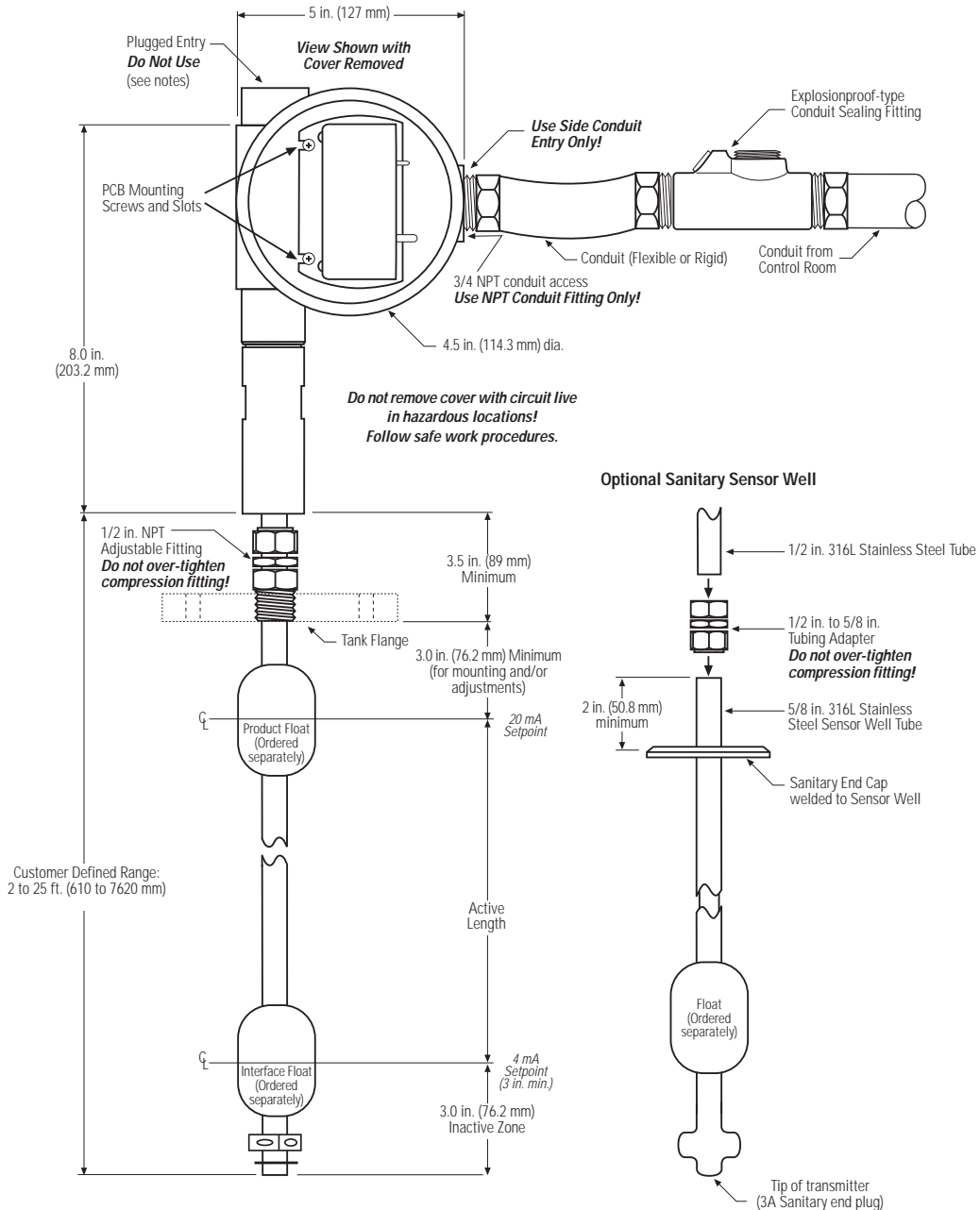

**Figure 8-2**  
**Typical Transmitter Installation**

## 9 ADJUSTMENTS FOR LEVEL PLUS A4 TRANSMITTERS (MANUAL)

---

### 9.1 Alarm Settings

---

When a fault condition is detected by the internal microprocessor, the 4 to 20 mA current will go to the current selected. To select the fault current, remove the alarm jumper, and replace it in either the 4 mA or the 20 mA position. The alarm jumper is a rectangular, black plastic piece located inside the dotted line box labeled “Alarm” on the front panel.

If in the 4 mA alarm mode when a fault is detected, the output will be continuous at  $3.8 \pm 0.1$  mA. If in the 20 mA alarm mode when a fault is detected, the output will be continuous at  $22.0 \pm 0.2$  mA.

### 9.2 Calibration (Manual)

---

**CAUTION!**

*Care should be taken when calibrating the temperature output. DO NOT PRESS the ‘ADJUST’ switch without first applying the proper RTD input.*

The Level Plus A4 transmitter can be calibrated manually, or via HART. This section describes manual calibration. Calibration using HART is described in Section 11.

**NOTE:**

*If HART is being used, disable all HART communications before performing a manual calibration.*

1. Loop 1 is permanently assigned to level #1. Temperature is assigned to loop 2 at the factory. Loop 2 can be reassigned to indicate level #2, or nothing, using a HART communicator programmed with the device descriptor. Loop 1 update time will be slightly faster if nothing is assigned to loop 2. See Section 10 for information on HART communication.
2. Remove the calibration jumper from the OFF position, and place it in the ON position. This enables the calibration mode. The calibration jumper is a rectangular, black plastic piece located inside the dotted line box (labeled ‘CAL’) on the front panel.
3. Move the “SELECT” switch to either loop 1 or loop 2. The “SELECT” switch has a lock, and the lever must be pulled out before it can be moved.
4. Move the float along the probe to the desired position for 4 mA.
5. Press the “ADJUST” switch down (labeled “4mA”) and release. Do not hold down for more than one (1) second.
6. Move the float along the probe to the desired position for 20 mA.
7. Press the “adjust” switch up (labeled “20 mA”) and release. Do not hold down for more than one (1) second.

8. Move the calibration jumper back to the “OFF” position. Calibration is now complete.

To adjust temperature calibration when loop 2 is assigned to temperature, remove the RTD wires from positions 1 and 2 of the RTD connector on the front panel. Connect an external RTD simulator to RTD terminals 1 and 2. Calibration on loop 2 is then continued as listed previously, setting the simulator to the desired temperatures for the 4 and 20 mA points. When finished, reconnect the RTD wires.

### 9.3 Damping Control (Manual)

---

Damping is adjustable using the toggle switches or the HART Communicator. There are six possible levels of damping available (see table below). Follow the appropriate instructions to adjust the damping as needed to slow down the level output response times. The damping value set for level #1 is also applied to level #2. For the temperature output, damping is fixed. There are two considerations to remember when making damping adjustments:

1. If temperature is enabled, damping will increase by a small amount.
2. Continuous HART communications will affect the damping.

#### Damping Adjustment Using Toggle Switches

1. The “SELECT” switch should be in the center position.
2. Set damping to minimum by toggling the “ADJUST” (damp) switch down and hold for one (1) second (minimum) and then releasing. This gives you a frame of reference to start from.
3. Increase damping by toggling the “ADJUST” (damp) switch up and holding it for one (1) second (minimum) and then releasing it for one (1) second.
4. For more damping, repeat step three. Press the toggle switch up the number of times that is necessary for the desired damping shown on the table below.

**Table 9-1 Damping**

DAMPING VALUE	DAMPING (contingent dependent)
0	<0.5 seconds
1	2.5 seconds
2	5.0 seconds
3	10.0 seconds
4	15.0 seconds
5	30.0 seconds

## 10 HART COMMUNICATION

Level Plus A4 transmitters are provided with HART communications capabilities. This may be achieved by using a portable HART communicator, or by using the the loop connections when working with a HART-capable interface. To use a portable HART communicator, connect its two leads to the test points labeled "HART + -" on the A4 transmitter module.

Permanent connections to the A4 transmitter for purposes of HART communications can be made by wiring a 250  $\Omega$  to 500  $\Omega$  resistor in series with loop 1 (refer to Loop Resistance vs. Power Supply graph in section 5.2). This can be done on the non-hazardous side of the safety barrier. A converter may also be used to convert the HART signals into EIA-232C signals. The converter can be used to connect a PC to the HART network.

**NOTE:**

*When using HART to write information, such as 'setpoints' to the A4 memory, the CAL jumper must be in the ON position.*

### 10.1 Character Coding

HART messages are coded as a series of 8-bit bytes that are transmitted via serial cable using a conventional UART (Universal Asynchronous Receiver/Transmitter) function to serialize each byte. As in EIA-232 and other asynchronous communication links, a start bit, a parity bit, and a stop bit are added to each byte. These allow the receiving UART to identify the start of each character, and to detect bit errors due to electrical noise or other interference. HART uses odd parity. A single 8-bit byte is therefore sent as the following sequence of 1s and 0s:

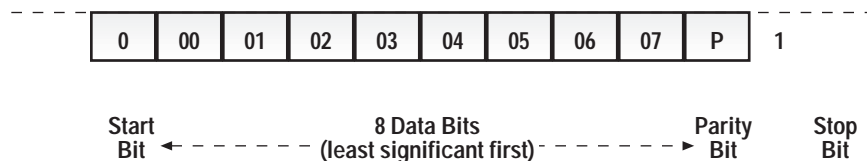

**Figure 10-1**  
**Single 8-Bit Byte Sequence**

**NOTE:**

*The serial port on an IBM (or compatible) PC cannot be set to this combination of 8 data bits plus parity, either by the DOS MODE command or by the IBM BASIC "OPEN COM" instruction. Many other varieties of BASIC do allow this combination. If necessary, it can be set up in any programming language by using low-level machine functions.*

HART protocol is asynchronous; successive characters may be separated by idle periods (at the logical 1 level).



## 10.2 Message Format

---

HART protocol specifies a message structure as follows:

PREAMBLE	START CHARACTER	ADDRESS	COMMAND	BYTE COUNT	[STATUS]	[DATA]	CHECKSUM
----------	-----------------	---------	---------	------------	----------	--------	----------

**Figure 10-2**  
**Message Structure**

HART protocol is half-duplex; after completion of a message, the FSK signal must be switched off to allow the other station to transmit.

The individual items in the above message are explained in the following paragraphs.

### ■ Long and Short Frame Formats

In a long frame format, the address of a slave device is a unique 38-bit number derived from the manufacturer code, the device type code, and the device identification number. This format provides extra security against acceptance of commands meant for other devices due to external interference or excessive crosstalk. It also expands the addressing capability of the HART protocol to allow for larger networks such as using a common radio link to a large number of remote field devices.

The A4 transmitter uses the long frame format except for command 0 ("Read unique identifier") which uses the short frame format. Because the reply to this command includes the device command revision levels, a master can determine the format used by each field device.

### ■ Preamble

The preamble consists of between two to twenty hexadecimal FF characters (all 1s) allowing the receiving modem to get its frequency-detection circuits synchronized to the signal after any pause in transmission. The A4 transmitter must see at least two preamble characters to recognize a message is being received.

### ■ Start Character

The start character in a HART message has various values, indicating which frame format is being used and the source of the message.

**Table 10-1**  
**Start Character Definition**

	Short Frame	Long Frame
<b>Master to Slave:</b>	02 (Hex)	82 (Hex)
<b>Slave to Master:</b>	06 (Hex)	86 (Hex)

Receiving devices acknowledge the start of the message by recognizing these characters as the first character after at least two FF preamble characters.

### ■ Address

The address field contains both the host and field device addresses for a message. These may be contained in a single byte (short frame format) or in five bytes (long frame format).

In either format, the single-bit address of the master is the most significant. Only two masters are allowed—for example, a control system and a hand-held communicator. The most significant bit of the address field differentiates these two hosts. Primary masters, such as control systems, use address 1 and secondary masters, such as hand held devices, use address 0.

In the short frame format, slave devices can have polling addresses in the range 0 to 15. This number is included in binary form as the least significant half of the single address byte. Therefore, the short frame address field is as follows:

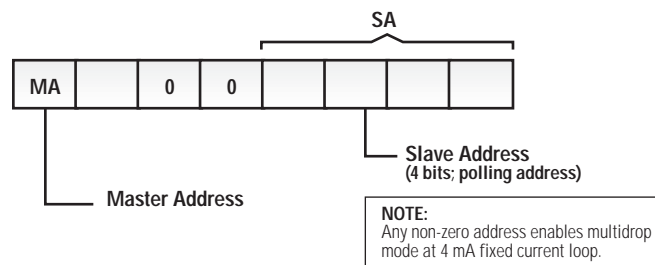

**Figure 10-3**  
**Address: Short Frame Format**

(The two 0 bits are not used at present. They are reserved as a possible logical sub-address within a single field device.)

In the long frame format, the remaining 38 bits of the five-byte address field hold the slave unique identifier as an address. Therefore, the long frame format address field is as follows:

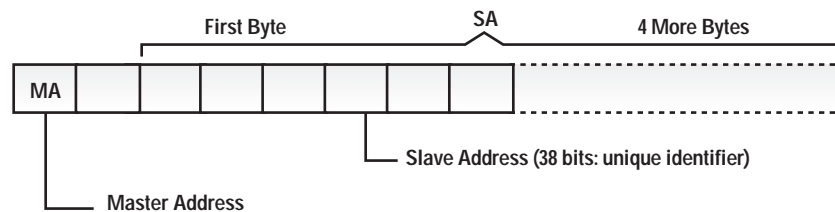

**Figure 10-4**  
**Address: Long Frame Format**

In the long frame format, 0 (38 zeros) can be used as a broadcast address for acceptance by all slave devices (though only one should reply; this will be determined by data in the message).

### ■ **Command**

The command byte contains an integer (0 to hex FF or decimal 255) that represents one of the HART commands. The number “254” is defined as an expansion code and is followed by another byte allowing more than 256 different commands to be defined if necessary.

The received command code is echoed back by the slave device in its reply.

There are three categories of commands: universal commands, common practice commands, and transmitter-specific commands.

Summaries of universal and common-practice commands are given in the end of this section.

### ■ **Byte Count**

The byte count character also contains an integer representing the number of bytes that form the remainder of this message. In the status and data sections; the checksum byte is not included in this count. The receiving device uses this to identify the checksum byte and determine that the message is complete.

### ■ **Status**

Status is included only in reply messages from the A4 transmitter. It consists of two bytes of bit-coded information. The first byte indicates communication errors, if any. Otherwise, if communication was good, this byte may indicate the status of the received command (such as a busy device, or a command not recognized). The second status byte indicates the operational state of the slave device. A properly operating slave device will have both status bytes set to logic zero.

The meaning of individual status bits are summarized at the end of this section.

### ■ **Data**

Not all messages contain data. For those that do, up to 24 bytes can be included. Data may be in the form of unassigned integers, floating point numbers, or ASCII character strings.

### ■ Checksum

The checksum byte contains the exclusive-or (longitudinal parity) of all the bytes that precede it in the message starting with the "start" character. This provides a further check on transmission integrity, beyond the parity check on the 8 bits of each individual byte. The combination guarantees to detect any single burst of up to three corrupted bits in a message, and has a good chance of detecting longer or multiple bursts.

An example transaction (short frame format) starts with a message from the master device. In the short frame format:

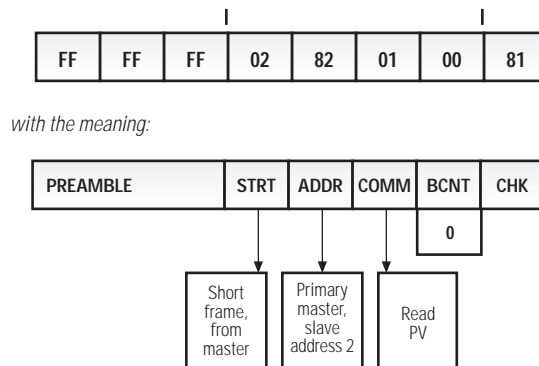

**Figure 10-5**  
**Example: Short Frame Message**

### 10.3 Using the HART Interface

---

The HART interface has two primary functions; device calibration and data acquisition. In all applications, being able to calibrate the transmitter without having to remove it from the process is a great advantage. This benefit can be seen on a simple 4-20 mA loop where the HART interface may only be used for the purpose of calibration. However, by taking advantage of the data acquisition features of HART, you have the speed associated with the 4-20 mA loop (instantaneous current change) plus the precision inherent to HART digital transmissions (floating point numeric data).

Level data can be retrieved from the A4 transmitter using HART commands. The level data retrieved in this manner is in inches or millimeters depending on your selected unit of measure. Temperature data retrieved in this manner is in degrees Fahrenheit or Celsius depending on your selected unit of measure. All data (level or temperature) output via the HART protocol is in the IEEE 754 floating point format. This allows for a very large range of numeric data ( $1 \times 10^{38}$  to  $1 \times 10^{-38}$ ). The HART interface will allow up to two commands per second to be processed.

The HART interface also allows transmitters to be multi-dropped on a single 2-wire loop. On a multi-drop system, the current for each device will be "parked" at 4 mA. All data is transmitted digitally. Up to fifteen devices may be attached to a single loop. A "device" may be an A4 level transmitter or some other HART compatible instrument. Each device has a distinctive 38-bit address, allowing a HART controller to determine the manufacturer, model number, and serial number of each device. The A4 transmitter must be assigned a polling address greater than zero, but less than sixteen in a multi-drop application. This can be done with a hand held communicator. When the polling address is greater than zero, the current is "parked" at 4.0 mA.

The ZERO (or 4 mA) position is seen as 0.0 inches (or millimeters) when making a level measurement. When the float moves from the ZERO position towards the SPAN position, the displacement

output is positive. If the float goes below the ZERO position, the displacement output is negative.

#### **10.4 HART Commands**

---

There are three main categories of HART commands:

- 1.) Universal
- 2.) Common Practice
- 3.) Device Specific

Table 10-2 shows the HART commands supported by the A4 transmitter. MTS reserves the right to add or delete commands without prior notice. Any commands sent to the A4 transmitters that are not supported will result in a "command not supported" response message. Currently, device specific commands are not supported.

**Table 10-2**  
**Universal Commands**

COMMAND NO. & FUNCTION	DATA IN COMMAND	(TYPE)	DATA IN REPLY	(TYPE)
0 Read unique identifier	none		Byte 0 "254" (expansion) Byte 1 manufacturer identification code Byte 2 mfr's device type code Byte 3 number of preambles Byte 4 universal command revision Byte 5 transmitter-specific cmd revision Byte 6 software revision Byte 7 hardware revision (H) Byte 8 device function flags (B) Byte 9-11 device ID number	
1 Read primary variable	none		Byte 0 PV units code Byte 1-4 primary variable (F)	
2 Read current and percent of range	none		Byte 0-3 current (mA) (F) Byte 4-7 percent of range (F)	
3 Read current and four (predefined) dynamic variables	none		Byte 0-3 current (mA) (F) Byte 4 PV units code Byte 5-8 primary variable (F) Byte 9 SV units code Byte 10-13 second variable (F) Byte 14 TV units code Byte 15-18 third variable (F) Byte 19 FV units code (NA) Byte 20-23 fourth variable (NA) (F)	
<b>NOTE: Fourth variable is not implemented</b>				
6 Write polling addr.	Byte 0	polling address	as in command	
11 Read unique ident. associated with tag	Byte 0-5	tag (A)	as command 0	
12 Read message	none		Byte 0-23 message (A)	
13 Read tag, descriptor, date	none		Byte 0-5 tag (A) Byte 6-17 descriptor (A) Byte 18-20 date (D)	
14 Read PV sensor information	none		Byte 0-2 sensor serial number Byte 3 units code for sensor limits and min span Byte 4-7 upper sensor limit (F) Byte 8-11 lower sensor limit (F) Byte 12-15 minimum span (F)	
15 Read output information	none		Byte 0 alarm select code Byte 1 transfer function code Byte 2 PV/range units code Byte 3-6 upper range value (F) Byte 7-10 lower range value (F) Byte 11-14 damping value (sec) (F) Byte 15 write-protect code Byte 16 private-label distributor code	
16 Read final assembly number	none		Byte 0-2 final assembly number	
17 Write message	Byte 0-23	message (A)		
18 Write tag, descriptor, date	Byte 0-5 Byte 6-17 Byte 18-20	tag (A) descriptor (A) date (D)	as in command	
19 Write final assembly number	Byte 0-2	final assembly number	as in command	

**Table 10-3**  
**Common Practice Commands**

COMMAND NO. & FUNCTION	DATA IN COMMAND		(TYPE)	DATA IN REPLY		(TYPE)
34 Write damping value	Byte 0-3	damping value (sec)	(F)	as in command		
35 Write range values	Byte 0	range units code		as in command		
	Byte 1-4	upper range value	(F)			
	Byte 5-8	lower range value	(F)			
36 Set upper range value (= push SPAN button)	none			none		
37 Set lower range value (= push ZERO button)	none			none		
49 Write PV sensor serial number	Byte 0-2	sensor serial number		as in command		
59 Write number of response preambles	Byte 0	number of response preambles		as in command		
60 Read analog output and percent of range	Byte 0	analog output code (see Table 10-7)		Byte 0	analog output code	
				Byte 1	analog output units	
				Byte 2-5	analog output level	(F)
				Byte 6-9	analog output percent	(F)
63 Read output information	Byte 0	analog output number		Byte 0	analog output number	
				Byte 1	alarm select code	
				Byte 2	transfer function code	
				Byte 3	units value	
				Byte 4-7	upper range value (URV)	(F)
				Byte 8-11	lower range value (LRV)	(F)
65 Write analog output range values	Byte 0	analog output number		as in command		
				Byte 1	units for range value	
				Byte 2-5	upper range value (URV)	(F)
				Byte 6-9	lower range value (LRV)	(F)

**Data Types:**

- **A:** ASCII string (packed 4 characters per 3 bytes)
- **B:** Bit-mapped flags (bit 0 = multi-sensor device; bit 1 = EEPROM control required)
- **D:** Date (day, month, year)
- **F:** Floating point (4 bytes IEEE 754)
- **H:** Integers xxxxx yyy (xxxxx = hardware rev., yyy = physical signalling code)
- Unmarked items are 8, 16, or 24-bit integers

**Table 10-4**  
**Status Coding**

<p><b>FIRST BYTE:</b></p> <p><b>BIT 7 = 1 Communication Errors:</b></p> <ul style="list-style-type: none"> <li>Bit 6 Parity Error</li> <li>Bit 5 Overrun Error</li> <li>Bit 4 Framing Error</li> <li>Bit 3 Checksum Error</li> <li>Bit 2 (Reserved)</li> <li>Bit 1 RX Buffer Overflow</li> <li>Bit 0 (Undefined)</li> </ul>	<p><b>FIRST BYTE:</b></p> <p><b>BIT 7 = 0 Communication Errors:</b></p> <p>Bits 6 to 0 (note bit-mapped)</p> <ul style="list-style-type: none"> <li>0 No command-specific error</li> <li>1 (Undefined)</li> <li>2 Invalid Selection</li> <li>3 Passed parameter too large</li> <li>4 Passed parameter too small</li> <li>5 Too few data bytes received</li> <li>6 Transmitter-specific command error</li> <li>7 In write-protect mode</li> <li>8-15 Command-specific error (see Table below)</li> <li>16 Access restricted</li> <li>32 Device is busy</li> <li>64 Command not implemented</li> </ul>
<p><b>SECOND BYTE:</b></p> <ul style="list-style-type: none"> <li>Bit 7</li> <li>Bit 6</li> <li>Bit 5</li> <li>Bit 4 all 0</li> <li>Bit 3</li> <li>Bit 2</li> <li>Bit 1</li> <li>Bit 0</li> </ul>	<p><b>SECOND BYTE:</b></p> <ul style="list-style-type: none"> <li>Bit 7 (hex 80) Device Malfunction</li> <li>Bit 6 Configuration changed</li> <li>Bit 5 Cold start</li> <li>Bit 4</li> <li>Bit 3 Output current fixed</li> <li>Bit 2 Analog output saturated</li> <li>Bit 1 Variable (not primary) out of limits</li> <li>Bit 0 Primary variable out of limits</li> </ul>

*Hex equivalents are shown, assuming only a single status indication is present.*



Code meanings can vary and are dependent upon the relevant command. The following table list some of the potential meanings for certain codes. Refer to the complete HART documentation to determine the appropriate code meanings for specific commands.

**Table 10-5**  
**Command-Specific Error Codes**

CODE	MEANING(S)
8	Update failed Update in progress Set to nearest possible value
9	Applied process too high Lower range value too high Not in fixed current mode
10	Applied process too low Lower range value too low Multi-drop not supported
11	In multi-drop mode Invalid transmitter variable code Upper range value too high
12	Invalid unit code Upper range value too low
13	Both range values out of limits
14	Pushed upper range value over the limit Span too small

**Table 10-6**  
**Unit Codes**

CODE	UNITS
32	Degree Celsius (°C)
33	Degree Fahrenheit (°F)
39	Milliamperes (mA)
47	Inches (in.)
49	Millimeters (mm)
57	Percent (%)

**Table 10-7**  
**Analog Output Codes**

CODE	FUNCTION
0	Level #1
1	Temperature
2	Level #2

## 11 ADJUSTMENTS FOR LEVEL PLUS A4 TRANSMITTERS (via HART)

---

Refer to the documentation supplied with your specific HART software package or hand held communicator for details on performing sensor calibration. This section describes how the HART protocol is applied to the A4 level transmitter only.

Using the HART interface allows for calibration without having to remove the transmitter from the process and position the floats. The HART commands 35 and 65 are implemented for this function. See Table 10-2 (HART message structure) for the data format of these commands.

Level #1 is always the primary variable (P.V.). Temperature is always the secondary variable (S.V.). Level #2 is always the third variable (T.V.). A4 transmitters currently do not have a fourth variable (F.V.). The analog output codes are 0, 1, and 2 respectively. The unit codes are located in Table 10-6 of this manual.

Calibration set points for level are given as the absolute displacement (in the appropriate units) from the tip of the sensor. For example, if the desired ZERO position for level #1 is given as 5 inches, the A4 will produce 4 mA when the float is 5 inches from the tip of the transmitter. If the desired SPAN position for level #1 is given as 30 inches, the A4 will produce 20 mA when the float is 35 inches from the tip of the transmitter. For calibration of the temperature set points, the ZERO and SPAN points are given in degrees. For temperature, the ZERO value (in degrees) must always be less than the SPAN value (in degrees).

### 11.1 HART Quick Start

---

The Level Plus A4 transmitter can be re-calibrated using a HART model 275 hand held terminal. Follow the simple instructions below to reset the low and high values for loop #1, "Level". Only loop #1 can be calibrated with the HART terminal. Loop #2 (Level ONLY) can be set manually with the switches on the PCB. Do not attempt to recalibrate loop #2 if configured for temperature output.

#### RULES:

1. Be sure the A4 is connected to a clean 24 Vdc power supply. Use a linear supply, switching types does not provide ripple free power. HART cannot tolerate more than a 25 mV voltage ripple.
2. If the unit is installed in a live application, place your automatic controllers in manual mode and be advised that the output current will change during calibration.
3. Follow safe working procedures as applicable for working on live equipment in a hazardous location. When safety is secured, remove housing cover.
4. Connect the HART communicator to the HART terminals on the A4 PCB.

#### NOTE:

*Be sure you have the transmitter loop #1 connected to a load of 250 to 500 Ohms. A unit installed in a control loop is a good example of this loop load. You may also use a load resistor in the range of the above value.*

5. Press the black and white "I/O" button on the HART terminal. The terminal will go into self test, then into the main screen. If not connected properly, you will get a "No device found" message.
- 6 From the main screen, press keypad key #1, "Device Setup".
7. From the "Device Setup screen, press key #3, "Basic Setup".
8. Press key #3, you are now in "Range Values" screen.

**To set low value**

9. To set the low value (4 mA), Select key #1, PV LRV (Process Variable, Lower Range Value). You are now in the PV LRV screen. The current low value is displayed. Below this value is a highlighted value. Key in the desired low value (example 3.00 in. is shown; if 4 inches is desired, key in 4.) When the new desired low value is keyed in, press "enter" (F4) button located below the LCD display, right. To write the changed lower value to memory, press the "SEND" key now. Next you will see two "WARNING" screens that ask if you are sure. If your new low values are correct, press "OK" for both messages.

This action resets the Lower Range Value, or 4 mA position into the transmitter's memory.

Go back to the "Range Values" screen to verify that the new parameters have been accepted into the transmitter memory.

You may now exit program mode or continue on to reset the upper value. If you choose to exit the program mode, replace the calibration jumper to the "ON" position, and return your controllers to automatic.

**To set high value**

10. You should now be in the "Range Values" screen. To set the 20 mA (Upper Range), press key #2. You are now in the "PV URV" (Process Variable, Upper Range Value) screen. As in the lower value screen, the current value is displayed with a highlighted number below it. To change the upper value, key in the desired value. You may use whole numbers or whole numbers and decimal numbers (40 = 40 inches, or 40.5 = 40.50 inches.) Whole numbers will be entered as their decimal equivalents by HART automatically. Key in the desired upper range value desired. Press the "Enter" (F4) button.

**CAUTION!**

*Do not enter a high value that exceeds the active length of the sensor!*

11. You are back in the "Range Values" screen. If the numbers for lower and upper are correct, press the "Send" key. You will get a "WARNING!". Press the "OK" button. You will again get "WARNING!" Press "OK" again.
12. Startup is now complete.

## **11.2 Damping Adjustment Using the HART Communicator 275**

---

1. Select "Device Setup" (key #1) from the main menu.
2. Select "Detailed Setup" (key #4) from the Device Setup menu.
3. Select "Signal Condition" (key #2) from the Detailed Setup menu.
4. Select "Snsr Damp" (key #2, then key #1) from the Signal Condition menu.
5. Input a Damping Value from the chart in the range of 0 to 5 that corresponds to the desired damping in seconds. Then press "ENTER" key. You will then be put back in the Signal Condition menu.
6. Press the "Send" key in the Signal Condition menu, and then the "OK" key twice when prompted.





**MTS Systems Corporation**

Sensors Division  
3001 Sheldon Drive  
Cary, NC 27513 USA  
Telephone: 800-457-6620  
Fax: 800-943-1145

**MTS Sensor Technologie  
Gmb and Co. KG**

Auf dem Schüffel 9  
D-58513 Ludensheid  
Federal Republic of Germany  
Telephone: +49-23-5195870  
Fax: +49-23-5156491

**MTS Sensors Technology Corporation**

Izumikan Gobancho  
12-11 Gobancho  
Chiyoda-ku, Tokyo 102  
Japan  
Telephone: +3-3239-3003  
Fax: +3-3262-7780



Level Plus is a registered trademark of MTS Systems Corporation  
HART is a registered trademark of the HART Foundation, Incorporated  
Teflon is a registered trademark of Dupont Corporation  
Hastelloy is a registered trademark of Haynes International, Incorporated  
All Level Plus products are covered by US patent number 5,545,984. Other patents pending.

1/98 550554 Revision A  
© 1997 MTS Systems Corporation