



Sensors Division

Level Plus[®] Analog Output Gauge
4-20 mA Level & Temperature Transmitter

*Ordering Guide &
Installation and Instruction Manual*

| SECTION | TABLE OF CONTENTS | PAGE |
|---------|--|------------------|
| 1 | INTRODUCTION | 1 |
| 2 | GAUGE DESCRIPTION 2.1 Theory of Operation | 1 2 |
| 3 | ELECTRICAL CONNECTIONS 3.1 Level Transmitter Specifications 3.2 Accuracy | 3 4 4 |
| 4 | ORDERING GUIDE 4.1 Model Number Generation 4.2 Additional information | 5 5 7 |
| 5 | MOUNTING 5.1 Threaded Mounting 5.2 Flange mounting 5.3 Sanitary Connection | 8 8 9 9 |
| 6 | WIRING PROCEDURES | 10 |
| 7 | ADJUSTMENTS FOR LEVEL TRANSMITTER | 12 |
| 8 | MAINTENANCE | 13 |
| 9 | FLOATS | 15 |
| 10 | TEMPERATURE TRANSMITTER 10.1 Temperature Transmitter Specifications 10.2 Temperature Transmitter Calibration Procedure | 16 16 17 |

GENERAL INFORMATION

| MTS PHONE NUMBERS | |
|---|---|
| To place orders: | 800-633-7609 or 919-677-0100 |
| Application questions: | 919-677-0100 |
| Service: | 800-248-0532 |
| Fax: | 919-677-0200 |
| SHIPPING ADDRESS | HOURS |
| MTS SYSTEMS CORPORATION Sensors Division 3001 Sheldon Drive Cary, North Carolina 27513 | Monday - Thursday 8:00 a.m. to 6:30 p.m. EST/EDT Friday 8:00 a.m. to 5:00 p.m. EST/EDT |

1 INTRODUCTION

MTS Sensors Division now provides the liquid level market with the Level Plus® magnetostrictive level gauge in a loop powered transmitter configuration. Although level transmitters based on pressure and capacitance sensors have been available for some time, this new MTS product brings the accuracy and stability of the Level Plus magnetostrictive technology to the level transmitter market.

2 GAUGE DESCRIPTION

The Level Plus 4-20 mA two wire gauge comprises three concentric members. The outermost protective jacket is a rigid 316 stainless steel, Kynar® or Teflon® tube.

A temperature sensing function is available as an option. It is a separate and independent 4-20 mA current loop. The temperature sensor is a Resistive Temperature Detector (RTD) which is located inside the stainless steel tube. The RTD is a 1000 Ω platinum film device, capable of an inherent accuracy of ± 0.5°F (0.28°C).

The innermost component is the waveguide. It has a very small diameter and is made of a proprietary magnetostrictive material. The unique properties of the waveguide enable the instrument to have excellent aging and temperature characteristics.

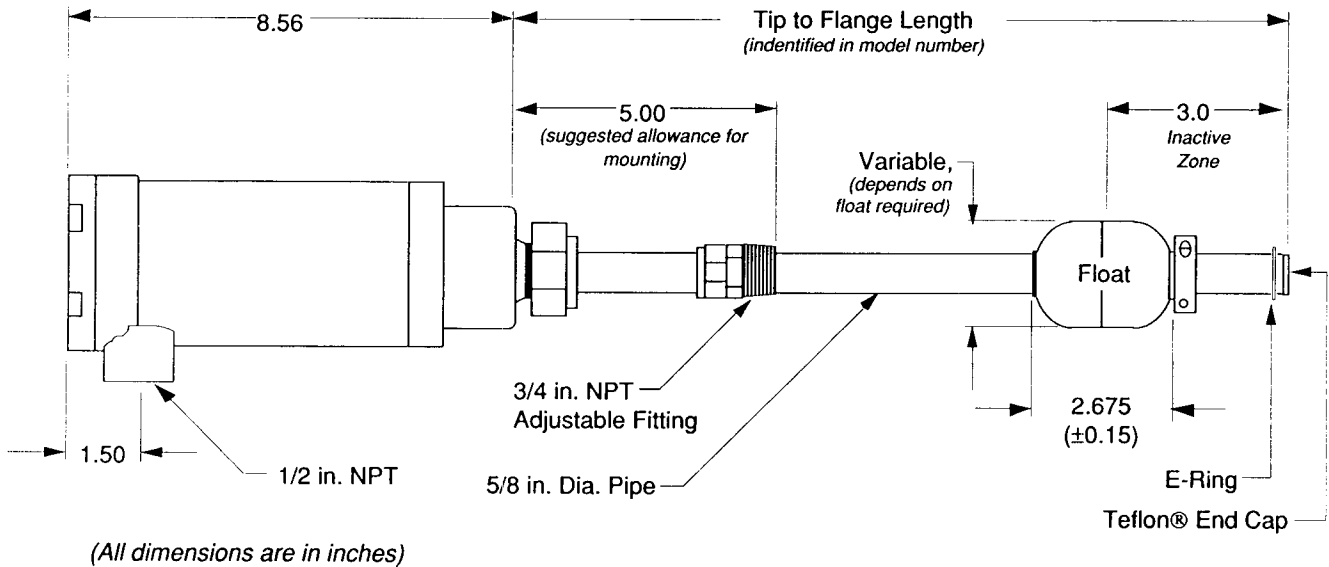

Figure 2.1 The Level Plus® 4-20 mA Gauge (Typical Configuration)

2.1 Theory of Operation

The magnetostrictive Level Plus gauge precisely senses the position of an external float by applying a short ($2\mu\text{s}$) high current pulse to the waveguide. This current pulse travels at the speed of light and causes a magnetic field to surround the waveguide. The magnet installed within the float also creates a magnetic field. Where the magnetic fields from the waveguide and float intersect, a rotational force is created. This, in turn, creates a torsional sonic pulse that travels along the waveguide (Refer to Figure 2.2).

The head of the gauge houses the sensing circuit, which detects the torsional sonic pulse and converts it to an electrical pulse. The distance from a reference point to the float is determined by measuring the time interval between the initiating current pulse and the return pulse, and by knowing the speed of these pulses through the medium of the waveguide. The resulting signal is then converted to a 4-20 mA loop signal.

Temperature measurements are separate and communicated over another pair of wires.

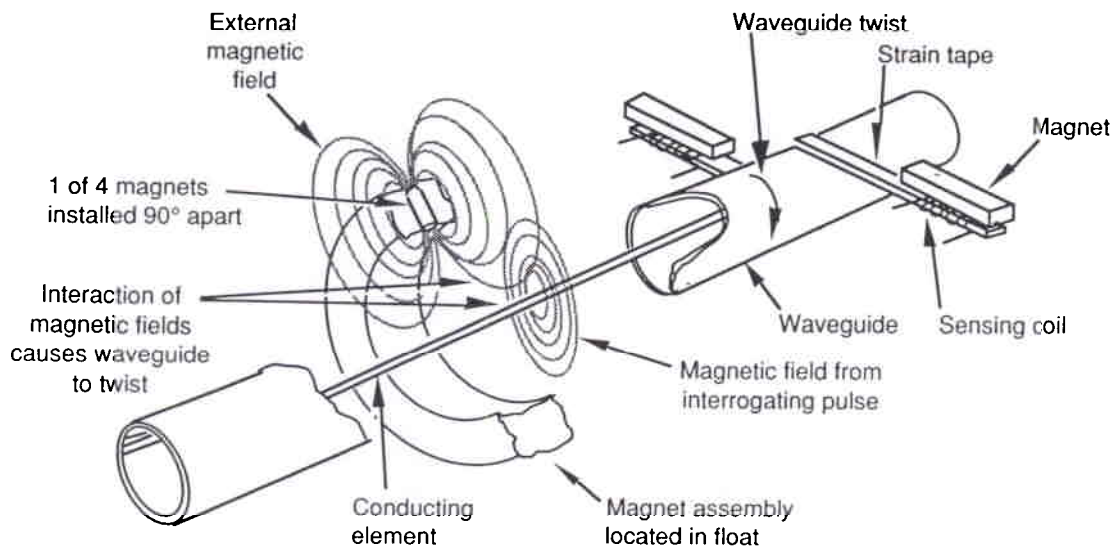
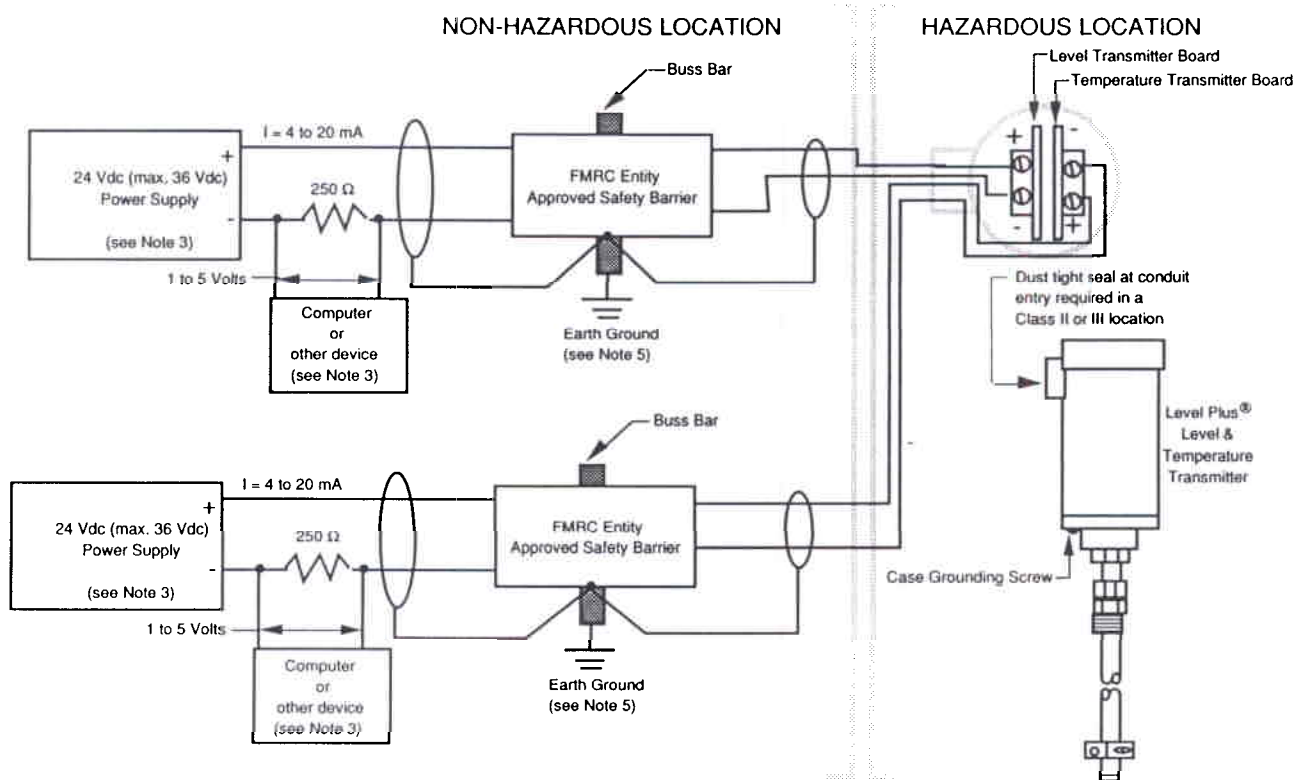

Figure 2.2 Level Plus® Operating Principle

3 ELECTRICAL CONNECTIONS

The 4-20 mA surface mount electronics can be easily replaced, in the field, without the on site support of the MTS service department. Plug-in boards allow upgrading the 4-20 mA gauge to Direct Digital Access (DDA) for digital communication. A typical connection for the level transmitter includes protective barriers, a power supply, and a reading device (Refer to Figure 3.1 below).



NOTES:

1. The I.S. field wiring shall be installed in accordance with the National Electric Code ANSI/NFPA 70 Article 504-30.
2. Shielded twisted cable of 24 AWG or heavier should be used. Cable capacitance shall be less than 30 picofarads per foot.
3. Control room equipment should not use or generate more than 250 V RMS.
4. For FMRC approved gauges, barriers must be FMRC approved.
5. The connection between the earth ground terminal of FMRC entity approved barriers and system earth ground must be less than 1 ohm.
6. Safety barriers are FMRC entity approved safety barriers used in an approved configuration where transmitter V_{max} is greater than barrier V_{oc} or V_t and transmitter I_{max} is greater than I_{sc} or I_t .
7. Transmitter C_i plus total cable capacitance for each loop must not exceed barrier C_a . Transmitter L_i plus total cable inductance for each loop must not exceed barrier L_a .
8. The transducer frame shall be grounded to earth ground directly or through the equipment on which it is mounted.
9. No revisions shall be made without notification of approval agency(s).
10. Intrinsically Safe for:
 - Class I, Division 1, Groups C and D
 - Class II, Division 1, Groups E, F, G
 - Class III, Division 1
11. Each loop entity parameter (printed on label)
 - $V_{max} = 36\text{ V}$
 - $I_{max} = 100\text{ mA}$
 - $C_i = 0\text{ }\mu\text{F}$
 - $L_i = 500\text{ }\mu\text{H}$
12. Temperature code is T3
13. Approved methods for separation of each loop are:
 - Running loops in separate cables.
 - Running loops in separate shields.
 - Using 0.25 mm (0.01 inch) thick insulation suitable for the maximum temperature on each conductor.

Figure 3.1 4-20 mA Gauge Typical Electrical Connection

3.1 4-20 mA Level Transmitter Specifications

| PARAMETER | SPECIFICATION |
|--|---|
| Performance | |
| Measured Variable: | Single level |
| Full Range: | 2 to 20 ft. (610 mm to 6.1 m) minus 3 in. (76.2 mm) inactive zone (See Figure 2.1) |
| Non-linearity: | 0.035 % F.S. (Independent best straight line) or 1/32 in. (0.794 mm)* |
| Hysteresis: | 0.01 % F.S. or 0.015 in. (0.381 mm)* |
| Repeatability: | 0.01 % F.S. or 0.015 in. (0.381 mm)* |
| Time Constant: | 1 second |
| Input Voltage Range: | 10.5 to 36 Vdc (See Figure 6.2) |
| Reverse Polarity Protection: | Series diodes |
| Safety Approval: | FM intrinsic safety approval |
| Calibration | |
| Zero Adjust Range: | 3.6 to 5 mA |
| Span Adjust Range: | 80 to 100 % of full range |
| Factory Setting: | 0.1 % of span or 1/16 in. (1.59 mm)* |
| Environmental | |
| Sealing: | O-ring sealed for outdoor use (NEMA 4) |
| Humidity: | 0 to 100 % R.H. |
| Operating Temperature: | -34 to 71°C (-30 to 160°F) |
| Temperature Sensitivity: | • Zero: < 0.009 % per °C (0.005% per °F) |
| Vessel Pressure: | 1.896 MPa maximum (275 PSIG) |
| Materials (wetted parts): | 316 Stainless steel standard, other material available optionally |
| Minimum Life Expectancy: | 10 years |
| Field Installation Requirements | |
| Gauge Length: | Up to 20 ft. (6.1 meters) |
| Size (electronics enclosure): | 3.75 in. dia. x 8 in. long (9.53 cm dia. x 21.8 cm long) |
| Mounting: | 3/4 in. NPT adjustable fitting or optional 2-1/2 in. (6.35 mm) sanitary fitting |
| Wiring: | 2 wire connections, shielded cable or twisted pair to screw terminals through a 1/2 in. NPT conduit opening |

All specifications are subject to change without notice. Consult MTS for verification of specifications critical to your needs.

* Whichever is greater

3.2 Accuracy

The absolute accuracy of the gauge is a function of the manufacture of the waveguide. That is, any imperfections in the waveguide are reflected in the linearity of its output. The tolerances reflect a non-linearity of 0.035% full scale. Due to its high degree of repeatability, the differential accuracy is extremely high.

4 ORDERING GUIDE

4.1 Model Number Generation

The following information describes the ten fields in the Level Plus gauge model numbering guide (refer to Figure 4.2). Information about the gauge is based on this number, which should be indicated when asking questions about the gauge.

STYLE: 'A8

The style of the Level Plus 4-20 mA Level Gauge is "A8". "A" stands for "Analog" and describes the gauge as a loop transmitter with a 4-20 mA output, used for liquid level. The "8" indicates that the gauge is intrinsically safe.

UNIT DESIGNATOR:

The designator is a single digit indication of engineering units used. The choices are either 1 for inches and tenths (U.S. customary), or 2 for millimeters (metric).

LENGTH:

The gauge length is measured from the face of the gauge flange to the tip of the gauge. Normal installation requirements dictate that the desired gauge length for a vessel should be measured from the bottom of the vessel to the top of the vessel flange, plus 5 inches. This additional 5 inches allows for the various mounting configurations for above ground storage tanks. The gauge length should be accurately measured prior to ordering. Tank flexure during filling, the amount of adjustment available at the tank top, and changes due to temperature should be part of that consideration.

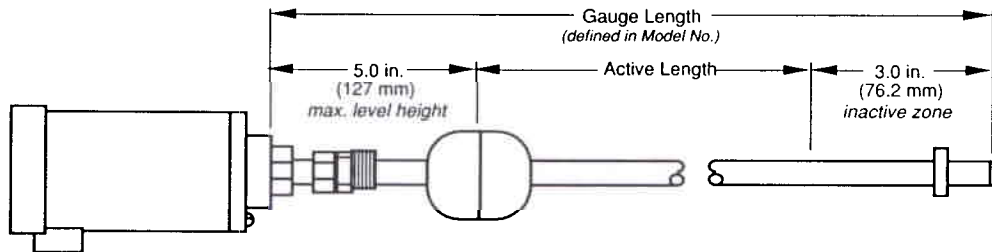

Figure 4.1 Gauge Length Specification

TEMPERATURE SENSING MODULE:

This refers to the optional RTD sensing module. The choices are either to include or not to include temperature sensing.

MOUNTING :

There are several ways to mount the gauge. Figures 5.1 and 5.2 show threaded and flange mounting, respectively. Figure 5.3 illustrates the sanitary connection. The following options are available:

- 6 3/4 " NPT adjustable fitting. This option is selected when an adjustable mounting is required. A threaded connector is included.
- 7 2 1/2" Sanitary connection. This option is selected when a sanitary connection is required. A sanitary fitting is included.

ROD MATERIAL

The rod material describes the type of material from which the Level Plus gauge rod will be constructed.

- 2 316 Stainless Steel: 275 PSI (1.896 MPa)
- 3 Kynar: 15 PSI (0.103 MPa)

How to Order Level Plus Analog Gauge by Model Number

| | | | | | | | | | |
|--|---|---|---|---|---|---|---|---|---|
| | A | □ | □ | □ | □ | □ | □ | □ | □ |
| STYLE _____ | | | | | | | | | |
| A8 Intrinsically safe (-30°F to 160°F, -34 to 71°C) | | | | | | | | | |
| DESIGNATOR _____ | | | | | | | | | |
| 1 Inches (xxx.0 inches) | | | | | | | | | |
| 2 Millimeters (xxxx.mm) | | | | | | | | | |
| LENGTH _____ | | | | | | | | | |
| Tank Height plus 5 inches (127 mm) | | | | | | | | | |
| NUMBER OF RTDS _____ | | | | | | | | | |
| 0 No Temperature Output | | | | | | | | | |
| 1 Temperature Output _____ inches from tip of gauge | | | | | | | | | |
| <i>Standard RTD location is 8 inches (203.2 mm) from tip of gauge. Special RTD location (optional), = _____ inches from tip of gauge.</i> | | | | | | | | | |
| MOUNTING _____ | | | | | | | | | |
| 6 3/4" NPT Adjustable Fitting | | | | | | | | | |
| 7 2 1/2" (63.5 mm) Sanitary Connection | | | | | | | | | |
| ROD MATERIAL _____ | | | | | | | | | |
| 2 316 Stainless Steel - 275 PSI (1.896 MPa) | | | | | | | | | |
| 3 Kynar - 15 PSI (0.103 MPa) | | | | | | | | | |

Required Information
(for processing of an order)

- 4 mA = _____ inches from the tip of gauge (3 inch minimum)
- 20 mA = _____ inches from the tip of gauge

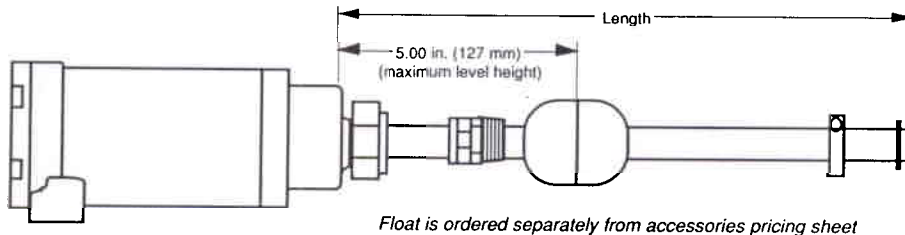

Figure 4.2 Level Plus® 4-20 mA Level Gauge Model Numbering Guide

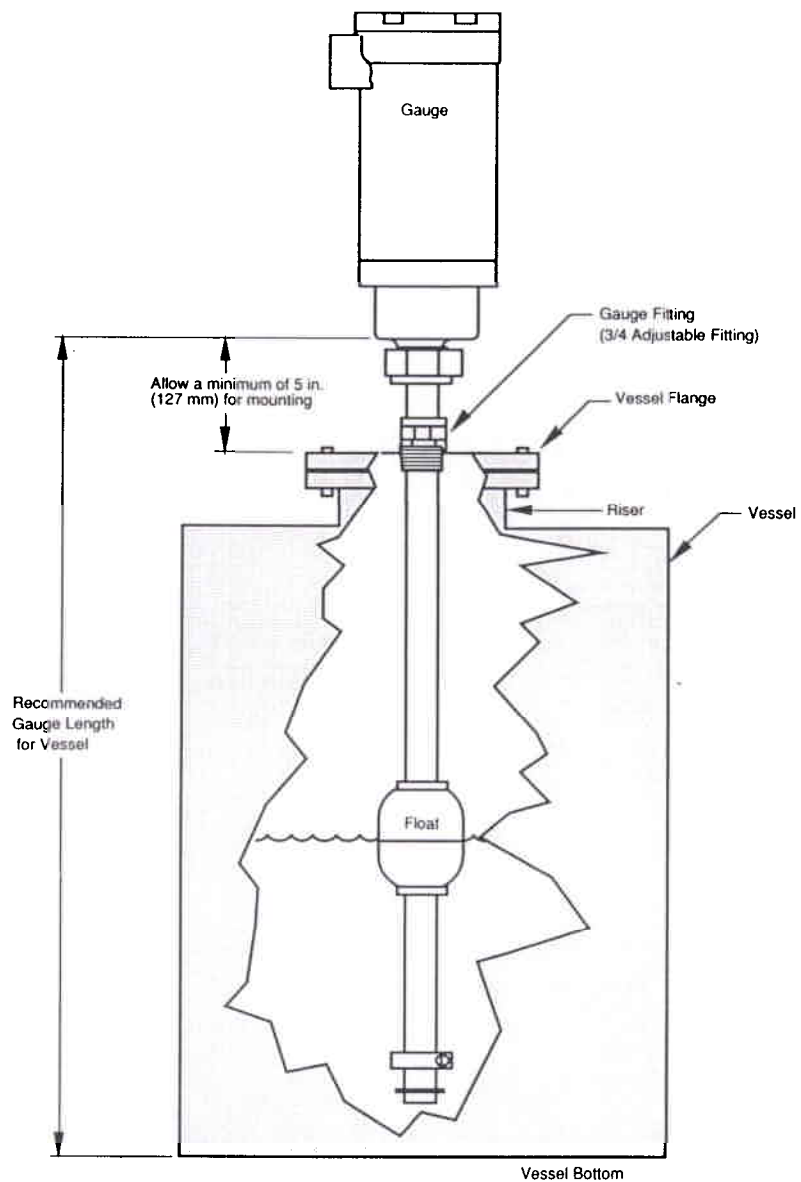

Figure 4.3 Gauge as Installed in Vessel

4.2 Additional Information

In addition to the model number, you must supply the following information: The material used in the floats (floats are available in 316 stainless steel, Kynar®, or Nitrophyl®), specific gravity, concentration, temperature of the product being measured, and the desired positions (mechanical dimensions) of the 4mA and 20mA set points.

5 MOUNTING

The method of mounting the gauge is dependent on the tank in which it is being used. For purposes of illustration, the two common means are discussed: Mounting directly to the tank or mounting in a reworked blind flange.

5.1 Threaded Mounting of a Gauge

In the case of a smaller tank, the gauge can be mounted directly to the tank, assuming proper wall thickness for sealing. Access must be available to mount the float on the gauge from inside the tank, such as through a nearby larger access.

Floats are first removed from the gauge by removing the collar or E-ring. The end of the gauge is inserted through the threaded opening and, by reaching from the other access, the float is installed. After fastening the collar or E-ring, the gauge is lowered into the tank and the screw connection is made at the top. The gauge length measurement should be accurately made at ordering time to take into consideration the flexure of the tank top while filling and the amount of adjustment available at the tank top.

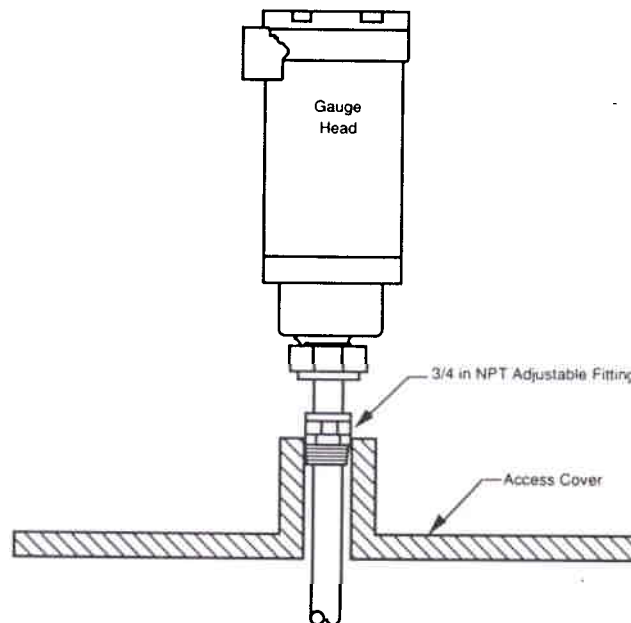

Figure 5.1 Threaded Mounting

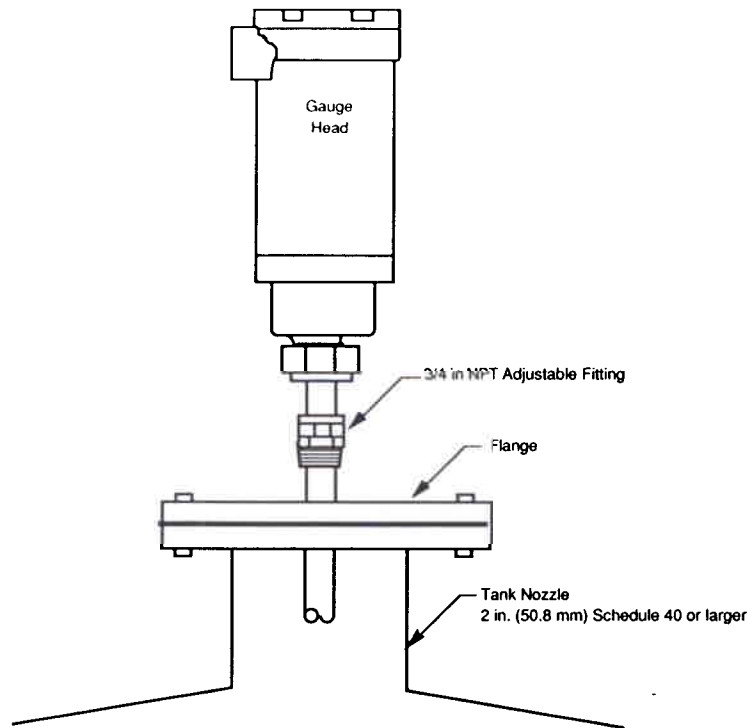

Figure 5.2 FlangeMounting

5.2 Flange Mounting

The gauge can also be mounted in a blind flange that has been drilled and tapped for the gauge. The float is first removed from the gauge, the gauge is mounted in the flange, the float is remounted, and the gauge is mounted as a unit on the tank from which the flange was removed. As the tank geometry changes with filling and temperature the gauge must be appropriately sized ("length") to take this into account.

5.3 Sanitary Connection

If the tank on which the gauge is to be mounted has a sanitary flange, MTS will provide a 2-1/2 inch Tri-Clover Tri-Clamp® flange.

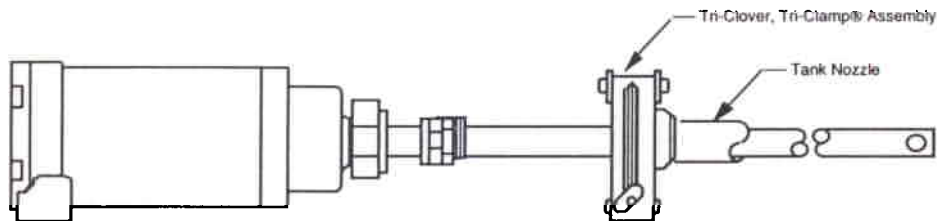
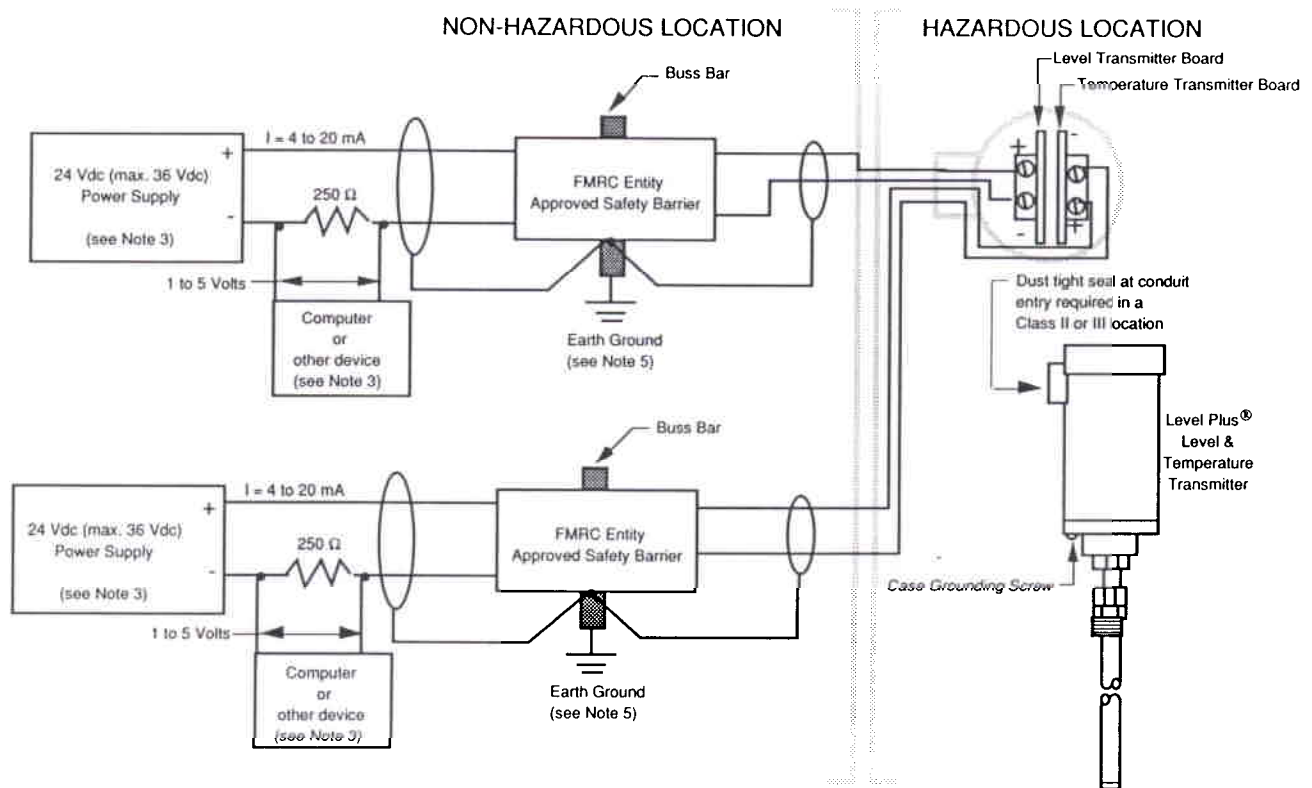

Figure 5.3 Sanitary Connection

6 WIRING PROCEDURES



CABLE NOTES:

1. Cable sets that run together must have sufficient insulation to withstand 250 RMS between sets. Electronic equipment connected to associated apparatus must not use or generate more than 250V RMS.
2. A twisted pair or shielded cable of #24 AWG or heavier gauge can be used. Cable capacitance shall be less than 30 pF per foot.
3. Cable parameters in hazardous areas must meet the requirements of the safety barrier manufacturer.
4. Maximum loop resistance vs. supply voltage is illustrated in Figure 6.2. Maximum resistance is the sum of cable resistance, safety barrier resistance, and load or other loop resistance.

GROUNDING NOTES:

1. The resistance between shunt safety barrier grounds and the system earth ground must be less than 1 ohm.
2. The gauge frame shall be connected to earth ground directly or through the equipment on which it is mounted.

Figure 6.1 Two-wire System

**4-20 mA Level Transmitter:
 Loop Resistance vs. Supply Voltage**
 $R_{Lmax.} = (V_{supply} - 10.5 \text{ Vdc}) \div (0.002 \text{ A})$
 $V_{supply \text{ max.}} = 24 \text{ Vdc} + (R_{Lmax.} \times 0.022 \text{ A})$

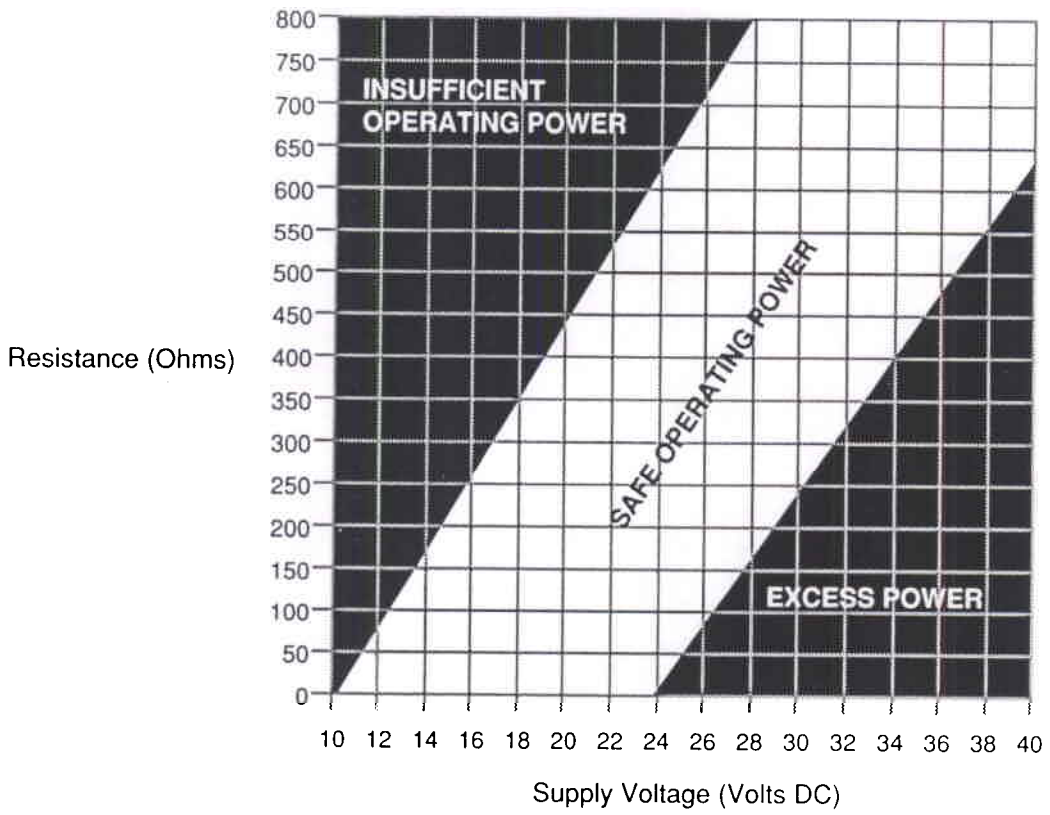

Figure 6.2 4-20 mA Level Transmitter: Loop Resistance vs Supply Voltage

7 ADJUSTMENTS FOR LEVEL TRANSMITTER

Each unit is factory calibrated to customer specification. In addition, adjustment in the field is possible by using the zero and span controls, see Figure 7.1

At no time should the factory adjust control be changed except by authorized personnel.

Zero and Span adjustment procedure:

1. Loosen the captive type cover screws until the cover can be removed.
2. Remove the cover.
3. Move the float to the position where 4 mA output is desired.
4. Adjust the zero control (marked "Z") until the loop current is 4 mA or equivalent.
5. Move the float to the position where 20 mA output is desired.
6. Adjust the span control (marked "S") until the loop current is 20 mA or equivalent.
7. Repeat steps 3 to 6 until no further adjustment is required.
8. Replace the cover and screws making sure the O-ring is properly in place.

NOTE

The lowest operational position of the gauge is with the float center line three inches (76.2 mm) above the gauge tip.

The switch (SW 1) is shown as set for 4 mA at the tip (SW 1-1 is OFF/OPEN and SW 1-2 is ON/CLOSED). If 4 mA at the flange is required, set SW 1-1 to ON/CLOSED and set SW 1-2 to OFF/OPEN.

SW 1-3 is to be used in conjunction with the optional field calibrator (available 3/93). It is ON/CLOSED for normal operation.

SW 1-4 is factory pre-set to OFF/OPEN, do not adjust.

VR3 is factory pre-set, do not adjust.

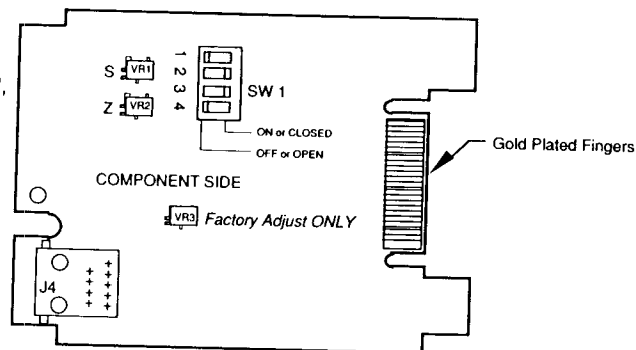

Figure 7.1 Zero and Span Controls

IMPORTANT:

Use this Addendum in place of Page 13 of the 4-20 mA Level & Temperature Transmitter Installation Manual (P/N 550068 Revision B)

⚠ CAUTION

NEVER attempt to repair a printed circuit card. Substitutions of electronic components may impair the intrinsic safety. Return damaged or malfunctioning cards to the factory for repair or replacement.

Install the 4-20 mA Transmitter Board(s) as follows:

1. Remove any dirt or debris from the top of the electronics enclosure.
2. Loosen the captive type cover screws until the cover can be removed.
3. Remove the cover -- take precautions to prevent any debris or moisture from entering the electronics enclosure.
4. Install the 4-20 mA Transmitter Board(s) by aligning the edges of the board with the grooves in the housing. The board will only fit one way in the housing. Do not try to force it in place. Note that the board has gold plated fingers on one end. Insert this end first so that it will slide into the connector. Refer to Figure 1 for proper alignment of Level Transmitter and optional Temperature Transmitter PCBs.

Note: Calibration, if required, can be performed at this time. All Temperature Transmitter Boards are factory calibrated, if additional calibration is desired, refer to Transmitter Board Calibration Procedure (Page 17).

5. Make appropriate electrical terminations as illustrated in Figure 1. When wiring to the Temperature Transmitter Board, make sure that you remove the shrink-wrap insulation on the end of each wire if using the MTS supplied cable. **DO NOT REMOVE** the heat shrink insulation if the Temperature Transmitter Board is not installed.
6. Remove the moisture-absorbing desiccant pack from the foil wrapping and insert it into the gauge housing as indicated in Figure 1.
7. Install the housing cover and tighten the six cover screws. When re-installing the cover, use the O-ring (supplied in PCB kit.) and moisten the sealing O-ring with silicone grease (supplied in PCB kit). This will keep the O-ring from drying out and sticking to the gauge housing, making the cover hard to remove. Note that the cover has a guide pin that determines the correct cover orientation.

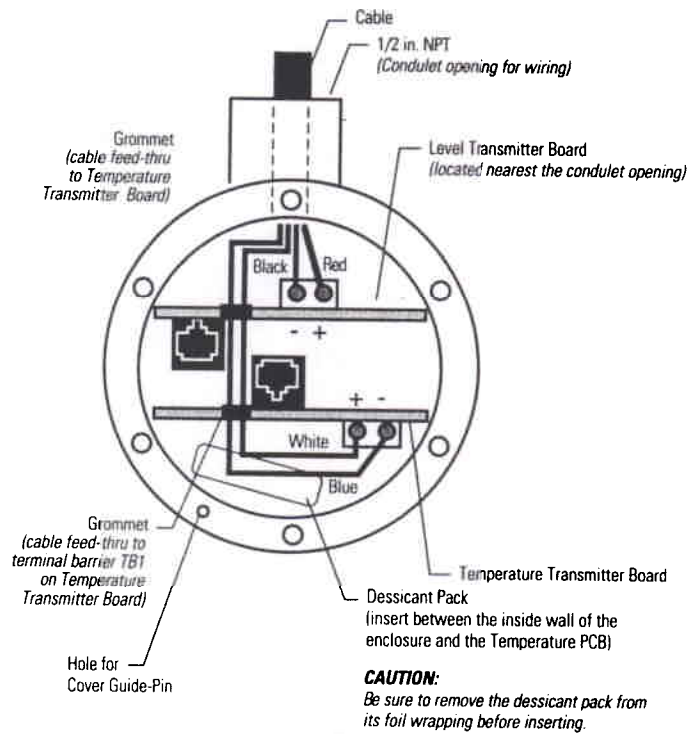

CAUTION:
Be sure to remove the desiccant pack from its foil wrapping before inserting.

| WIRE COLOR CODE | |
|-----------------|---------------|
| • Level | • Temperature |
| Red (+) | White (+) |
| Black (-) | Blue (-) |

Figure 1
Top View of Level Plus® Analog Level and Temperature Transmitter

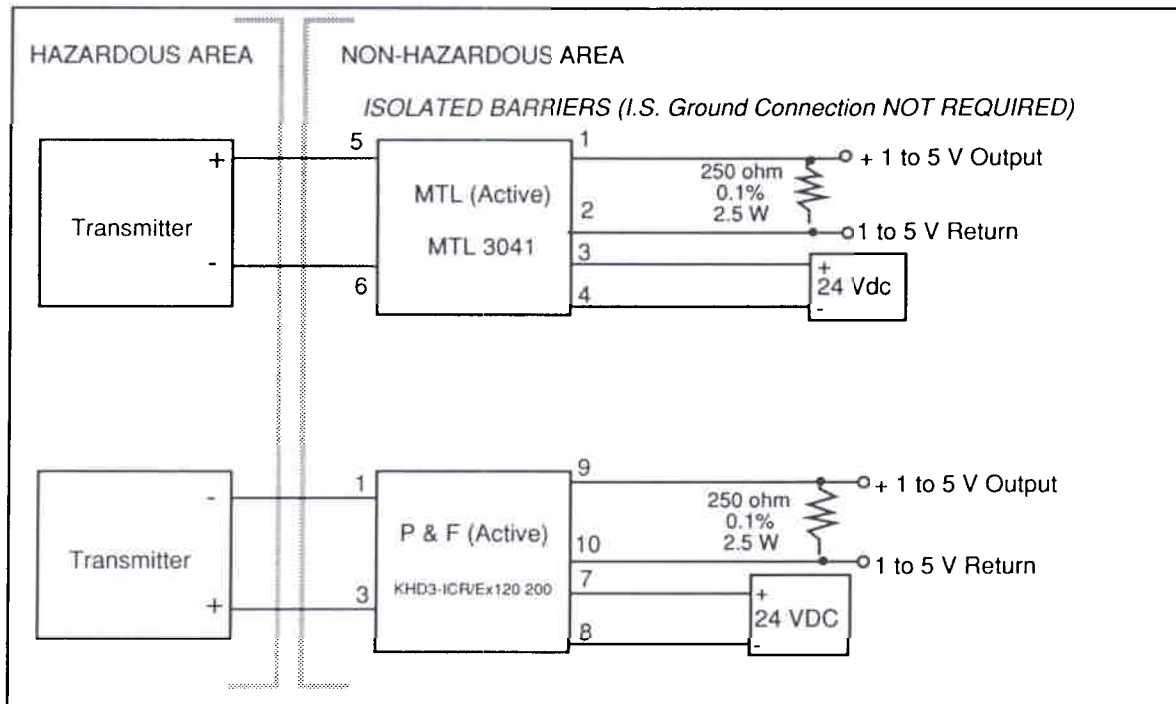
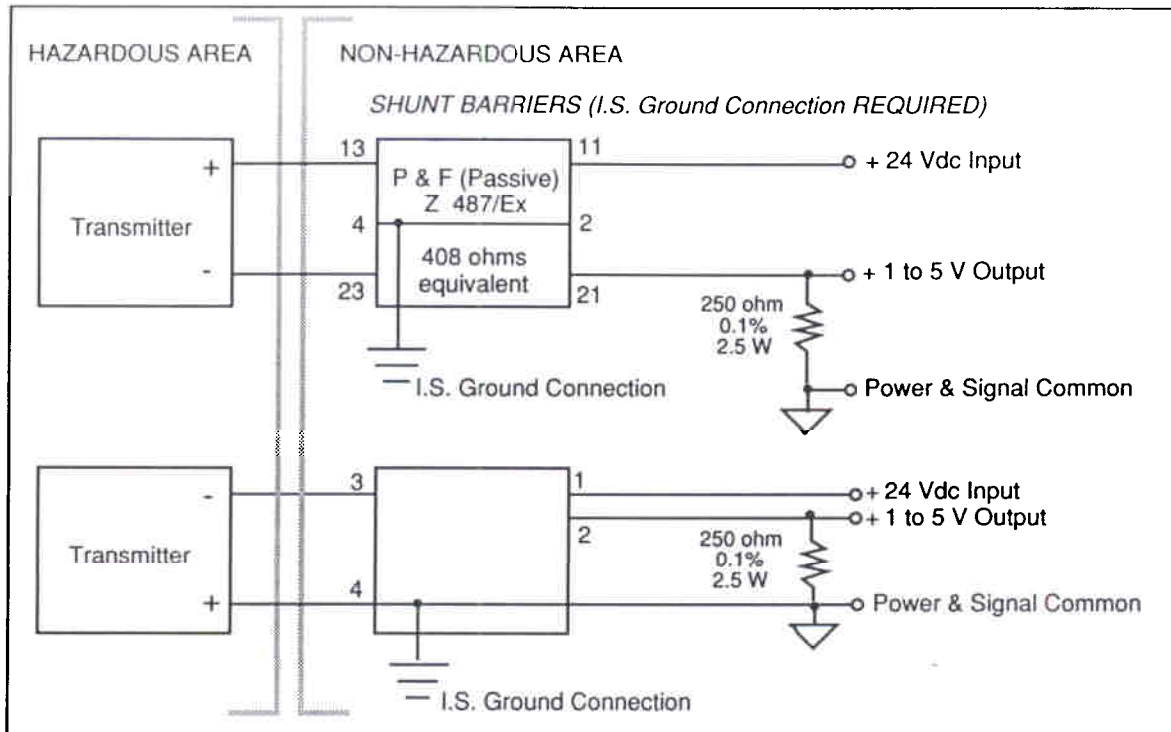

NOTES:

1. When selecting barrier types, the entity parameters for the Level Transmitter are:
 $V_{max} = 36 \text{ Vdc}$, $I_{max} = 100 \text{ mA}$ (total current), $C_i = 0 \text{ } \mu\text{F}$, $L_i = 500 \text{ } \mu\text{H}$
2. P&F = Pepperl and Fuchs (Phone: 216-425-3555); MTL = MTL Incorporated (Phone: 703-361-0111)

Figure 8.2 Suggested Barrier Types for 4-20mA Level Gauge

9 FLOATS

| Part Number | Material | Use | I.D. | O.D. | Height | Specific Gravity |
|-------------|-----------------------|---------------------------|-------|-------|--------|------------------|
| 200383 | Nitrophyl | Product | 0.720 | 3.750 | 3.000 | 0.44 |
| 200384 | Nitrophyl | Gas Interface | 0.720 | 3.750 | 3.000 | 0.79 |
| 200385 | Nitrophyl | Diesel Interface | 0.720 | 3.750 | 3.000 | 0.89 |
| 201126 | Nitrophyl | Gas Interface (plated) | 0.720 | 3.750 | 3.000 | 0.79 |
| 201127 | Nitrophyl | Diesel Interface (plated) | 0.720 | 3.750 | 3.000 | 0.89 |
| 250535 | Nitrophyl | Product | 0.720 | 2.000 | 3.000 | 0.35 |
| 250536 | Nitrophyl | Diesel Interface | 0.720 | 2.000 | 3.000 | 0.89 |
| 250537 | Nitrophyl | Gas Interface | 0.720 | 2.000 | 3.000 | 0.79 |
| 250553 | 316 SST | Product | 0.700 | 2.050 | 2.675 | 0.57 - 0.66 |
| 250554 | 316 SST | Interface (s.g. <1) | 0.700 | 2.050 | 2.675 | 0.90 - 0.93 |
| 250854 | 316 SST | Interface (s.g. >1) | 0.700 | 2.050 | 2.675 | 1.04 - 1.11 |
| 251875 | 316 SST | Product | 1.100 | 3.725 | 5.250 | 0.45 - 0.52 |
| 251066 | 316 SST | Interface (s.g. <1) | 1.100 | 3.725 | 5.250 | 0.90 - 0.93 |
| 251067 | 316 SST | Interface (s.g. >1) | 1.100 | 3.725 | 5.250 | 1.04 - 1.11 |
| 250709 | 316 SST | Product | 1.100 | 5.110 | 5.000 | 0.36 - 0.437 |
| 250714 | 316 SST | Interface (s.g. <1) | 1.100 | 5.110 | 5.000 | 0.90 - 0.96 |
| 250855 | 316 SST | Interface (s.g. >1) | 1.100 | 5.110 | 5.000 | 1.03 - 1.10 |
| 201108 | Kynar | Product | 0.700 | 2.380 | 3.000 | 0.70 |
| 251117 | Kynar | Interface (s.g. <1) | 0.700 | 2.380 | 3.000 | 0.90 - 0.95 |
| 251118 | Kynar | Interface (s.g. >1) | 0.700 | 2.380 | 3.000 | 1.04 - 1.11 |
| 201107 | Kynar | Product | 1.100 | 4.500 | 4.500 | 0.70 |
| 251121 | Kynar | Interface (s.g. <1) | 1.100 | 4.500 | 4.500 | 0.90 - 0.95 |
| 251122 | Kynar | Interface (s.g. >1) | 1.100 | 4.500 | 4.500 | 1.04 - 1.11 |
| 200941 | Nitrophyl | Product | 1.220 | 3.750 | 1.070 | 0.45 |
| 200931 | 316 SST (Sanitary) | Product | 0.680 | 2.340 | 3.000 | 0.60 |
| 200938 | 316 SST | Product | 0.700 | 1.610 | 1.295 | 0.61 - 0.72 |
| 201109 | Teflon(FEP) | Product | 0.700 | 2.380 | 3.000 | 0.86 |
| 251115 | Teflon (FEP) | Interface (s.g. <1) | 0.700 | 2.380 | 3.000 | 0.90 - 0.95 |
| 251116 | Teflon(FEP) | Interface (s.g. >1) | 0.700 | 2.380 | 3.000 | 1.04 - 1.11 |
| 201112 | Teflon(FEP) | Product | 1.100 | 4.500 | 4.500 | 0.86 |
| 251119 | Teflon(FEP) | Interface (s.g. <1) | 1.100 | 4.500 | 4.500 | 0.90 - 0.95 |
| 251120 | Teflon(FEP) | Interface (s.g. >1) | 1.100 | 4.500 | 4.500 | 1.04 - 1.11 |

*Nitrophyl is a Registered Trademark of Rogers Corporation,
Kynar is a Registered Trademark of Pennwalt Corporation,
Teflon is a Registered Trademark of DuPont Corporation*

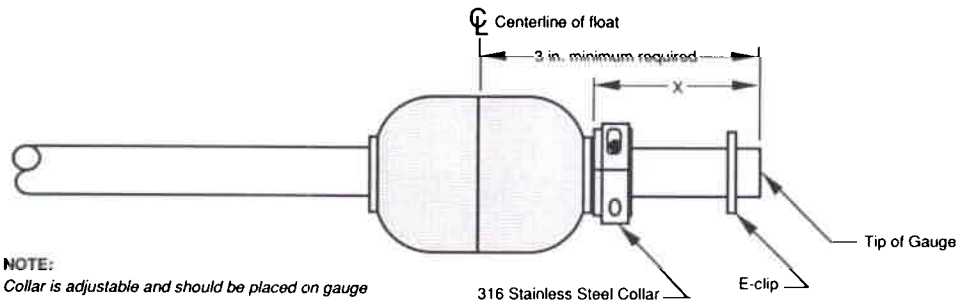

NOTE:

Collar is adjustable and should be placed on gauge such that the centerline of the float will not enter the 3 inch inactive zone of the gauge. Float sizes are variable so "X" indicated in the illustration is also variable.

Figure 9.1 Float Installation

10 TEMPERATURE TRANSMITTER

The 4-20 mA Temperature Transmitter is an optional feature on the Level Plus Analog Gauge. It provides an independent 4-20 mA current loop which can be used in conjunction with the level Transmitter. A separate well filtered 24 Vdc power supply is required with the temperature transmitter (the Level transmitter required its own 24 volt supply). The level and temperature transmitters each must have an independent pair of wires, an approved intrinsic safety barrier and a load resistor (Refer to Figure 3.1, Electrical Connections).

Loop resistance is defined as the aggregate of the intrinsic safety barrier resistance, the load resistance and cable resistance. Total loop resistance guidelines are illustrated in Figure 10.3. Each system must be operated as defined in the "Safe Operating Area" as indicated in Figure 10.3.

10.1 Temperature Transmitter Specifications

| PARAMETER | SPECIFICATION |
|------------------------------|--|
| Sensor | |
| Type: | Resistance Temperature Detector (RTD) 1,000Ω |
| Connection: | Kelvin Sensing |
| Interchangeability: | ± 0.3 °C (0.54 °F) |
| Repeatable: | ± 0.1 °C (0.18 °F) |
| System | |
| Range: | 4 mA = -30 °C (-22 °F); 20 mA = 70°C (158 °F) |
| Linearization: | Analog, continuous |
| Accuracy: | ± 1.5 °C (2.7 °F) -- non-linearity, hysteresis, and repeatability |
| Drift: | ± 0.5 °C (0.9°F) per year |
| Power Requirements: | 10.5 to 36 Vdc |
| Zero Adjust: | (-10%/+20%) -40 °C to -10 °C (-40 °F to 140 °F) |
| Span Adjust: | (±20%) Δ 80 °C to Δ 120 °C (Δ 176 °F to Δ 248 °F) |
| Approvals: | Factory Mutual Research (FM) Intrinsic Safety Approval |
| Reverse Polarity Protection: | Series Diode |

**4-20 mA Temperature Transmitter:
Loop Resistance vs. Supply Voltage**
 $R_{Lmax.} = (V_{supply} - 10.5 \text{ Vdc}) \div (0.002 \text{ A})$
 $V_{supply \text{ max.}} = 24 \text{ Vdc} + (R_{Lmax.} \times 0.022 \text{ A})$

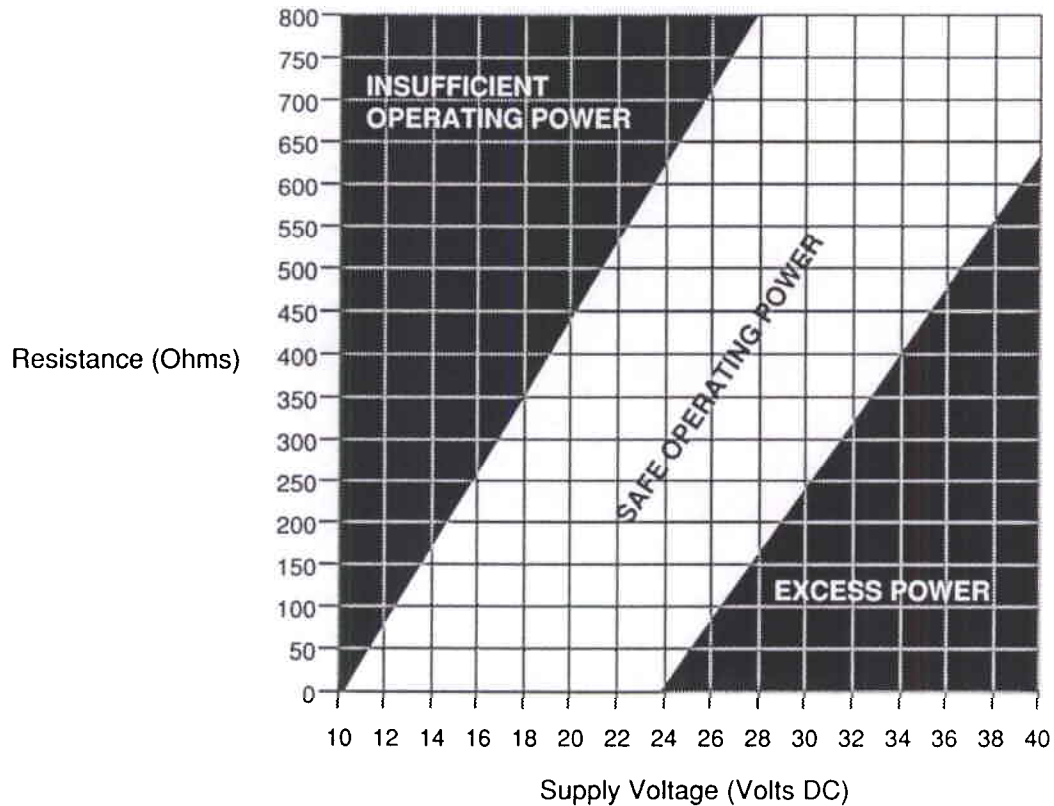

Figure 10.1

10.2 Temperature Transmitter Calibration Procedure

Equipment Required:

- Digital Volt Meter
 - Digital Milliammeter
 - DC. Power Supply (Adjusted to 24 Vdc)
 - Switch Tool (i.e., tweezers or potentiometer adjusting tool)
 - Potentiometer Adjusting Tool
1. Remove power from the gauge.
 2. Loosen the captive type cover screws until cover can be removed.
 3. Remove the cover of electronics enclosure
 4. Remove the 4-20 mA Temperature Transmitter PCB, MTS P/N 600145 from the electronics enclosure.
 5. Set dip switch S1 as follows:
 - Position 1 to ON
 - Position 2 to OFF
 6. Connect the milliammeter as indicated in Figure 10.2. R1 (250 Ω resistor) is not required, but is recommended when the gauge is installed in an atmosphere with electrical interference.

NOTE: An alternate way of measuring the current in the 4-20 mA loop is to measure the voltage across a resistor (resistor should not exceed 500Ω) placed in the loop and divide the voltage across that resistor by the value of that resistor. The resultant number is the current in amperes. A precision 1/2 Watt @ 0.1% resistor should be used for this method of measuring current; the milliammeter is not required.

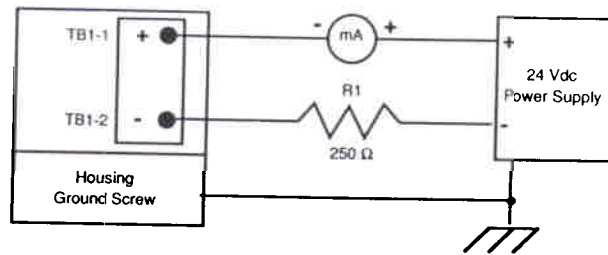

Figure 10.2

7. Do not adjust VR1 (trim). VR1 is a precision adjustment and must only be adjusted by an MTS trained technician. Adjustment of this potentiometer by someone other than an MTS trained technician will VOID the warranty.
8. Adjust VR2 (Zero) until the milliammeter reads 4 mA DC ($\pm 5 \mu\text{A}$).
9. Turn off 24 Vdc power supply and remove Temperature Transmitter PCB.
10. Set dip switch S1 as follows:
 - Position 1 to OFF
 - Position 2 to ON
12. Return the 4-20 mA Temperature Transmitter PCB to the electronics enclosure, reapply 24 Vdc power to the gauge and adjust VR3 (Span) until the current meter reads 20.0 mA DC @ $\pm 5 \mu\text{A}$.
13. Once again remove the power from the gauge and remove the Temperature Transmitter PCB, voltmeter, milliammeter and resistor R1..
16. Set BOTH switches (S1 Position 1 and S1 position 2) to OFF.
17. Return the Temperature Transmitter PCB to the electronics enclosure and install loop wires..
18. Ensure that the O-ring (located in the gauge housing cover) and the O-ring seat (located in the gauge housing) are clean, lubricated with a high viscosity O-ring fluid and correctly installed.
19. Replace the gauge housing cover, being careful not to cut O-ring, and tighten the captive type cover screws. Calibration is complete.

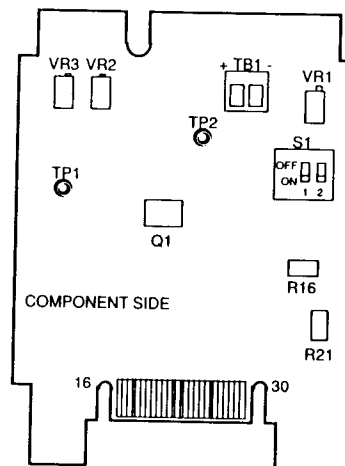

Figure 10.3 PCB Layout



MTS Systems Corporation

Sensors Division
3001 Sheldon Drive
Cary, NC 27513

Telephone: (919) 677-0100 Fax: (919) 677-0200

Printed in USA © Copyright MTS Systems Corporation
1292 – 550068 Revision B