



Sensors Division

TEMPOSONICS™

Linear Displacement Transducer System
with Analog Output

Installation and Instruction Manual

List of Figures

1-1	Linear Displacement Transducer System	1-1
2-1	Location of Position Adjustments and Terminal Boards on the AOM.	2-2
2-2	Velocity Adjustments on the AOM	2-4
3-1	Overall Dimensions, AOM	3-1
3-2	LDT Assembly	3-2
3-3	Magnetic Material Mounting Specifications	3-3
3-4	Flexible Transducer	3-6
3-5	Loop Support	3-8
3-6	Channel Support	3-9
3-7	Guide Pipe Support	3-10
3-8	Active Zone for Open Magnets	3-10
3-9	Typical Cylinder Installation	3-12
4-1	Cable Preparation for Strain Relief	4-1
4-2	J1 Connections (Strain Relief)	4-3
4-3	J1 Connections—Velocity Output (Strain Relief)	4-3
4-4	J2 Connections (Strain Relief)	4-6
4-5	Grounding the Analog System	4-8
5-1	Analog Output Module Signals	5-2

List of Tables

	Specifications	1-2
4-1	Voltage Output J1 Connections (MS Connector)	4-4
4-2	Ungrounded 4-20 mA Current Output J1 Connections (MS Connector)	4-4
4-3	Grounded 4-20 mA Current Output J1 Connections (MS Connector)	4-4
4-5	J2 Connections (MS Connector)	4-7

1 Introduction

The Temposonics™ II Linear Displacement Transducer measurement system (with analog output) precisely senses the position of an external magnet to measure displacements with a high degree of resolution. The system measures the time interval between an interrogating pulse and a return pulse. The interrogating pulse is transmitted through the transducer waveguide, and the return pulse is generated by a movable permanent magnet representing the displacement to be measured.

The system includes a linear displacement transducer (LDT), a magnet, and an analog output module (AOM). The AOM generates the interrogating pulse, senses the return pulse, and develops an analog output signal.

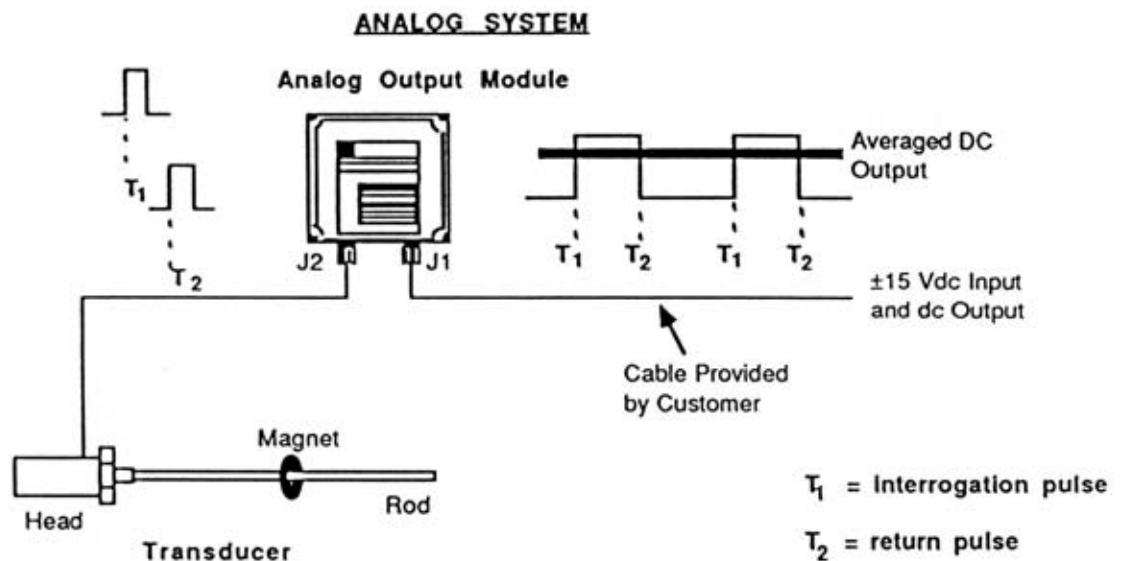

Figure 1-1. Linear Displacement Transducer System

Specifications

Parameter	Specification
Input voltage	+15 Vdc ($\pm 2\%$) at 250 mA, with <1% ripple -15 Vdc ($\pm 2\%$) at 65 mA, with <1% ripple
Displacement	Up to 30 feet (9 meters)
Nonlinearity	< $\pm 0.05\%$ of full scale or minimum ± 0.002 in. (± 0.05 mm)
Repeatability	< 0.001% of full scale or 0.0001 in. (0.0025 mm), whichever is greater
Frequency response	Depends on length and type of filtering. 200 Hz to 50 Hz is typical for lengths of 12 in. (30 cm) to 100 in. (254 cm) respectively. Wider response is available.
Temperature coefficient:	
Transducer	0.00018 inch/ $^{\circ}$ F (0.00011 inch) ≤ 12 inches stroke) + 3ppm/ $^{\circ}$ F/inch stroke - transducer 5ppm/ $^{\circ}$ F nominal for external electronics
Analog Output Module	20 ppm/ $^{\circ}$ F
Operating temperature:	
Transducer	-40 to 180 $^{\circ}$ F (-40 to 82 $^{\circ}$ C)
Analog Output Module	35 to 150 $^{\circ}$ F (2 to 66 $^{\circ}$ C)* Standard until July 1, 1990 -40 to 180 $^{\circ}$ F (-40 to 82 $^{\circ}$ C) Standard after July 1, 1990
Operating pressure	transducer rating 3000 psi (21 MPa) cyclical; 5000 psig (34 Pa) static
Output	0 to 10 Vdc and a other voltages are optional.
Output impedance	< 10 Ω
Velocity output	0 to ± 10 Vdc, positive traveling away from the LDT head assembly, negative traveling towards the LDT head assembly
Standard features of Analog Output Module	External noise rejection circuitry to eliminate EMI noise from motors, relays, or other sources. Low ripple filter to reduce ac ripple on the output signal to .5 mV maximum
* Options available	

Specifications are subject to change without notice. Contact M/S for verification of specifications. Price is for lead time.

2 Adjustments

This section explains how to adjust and calibrate the Temposonics Linear Position Transducer (LDT) system with analog output.

The Analog Output Module (AOM) includes adjustments for *null* (zero), and *full-scale* (span). The adjustments compensate for the following:

- differences between transducer *gradients*.
- small offsets in the magnet position due to mounting.
- wear in the moving parts of the mechanical system to which the magnet is attached.

In cases where a coupler device is used for adjusting the magnet (as described in Section 4), the coupler is used for coarse adjustments of both null and scale, while the AOM is used for fine adjustments.

Nominal Range of Adjustment

- Null: From $\pm \frac{3}{8}$ inch up to $\pm 3\%$ of total stroke
Full-scale: $\pm 2\%$ of total stroke

Figure 2-1 shows the location of position adjustments and terminal boards on the AOM.

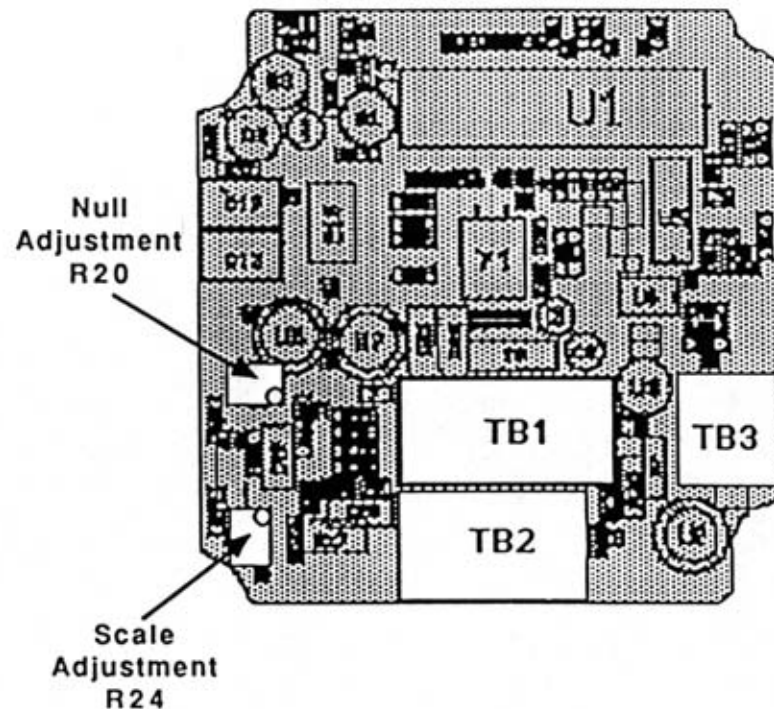

Figure 2-1. Location of Position Adjustments and Terminal Boards on the AOM.

NOTE

The adjustment values specified in the following procedures depend on the system configuration. The adjustment tolerances of these procedures during field calibration are dependent on system requirements and available test equipment.

Null and Full-Scale Adjustments

The following procedures calibrate the null position and the full-scale position to the required output levels. If the following adjustments are inadequate, refer to Subsection 3.2 for possible mechanical adjustments. Refer to Figure 2-1 for the adjustment locations.

NOTE

The following procedure assumes the standard full-scale 0 to 10 Vdc output is supplied. When other output signals are supplied, use the appropriate signal levels and test equipment for the following adjustments.

1. Disconnect all power from the system. Loosen the four screws securing the AOM cover, and remove the cover.
2. Note the location of terminal board TB1 on the AOM (Refer to Figure 2-1). Connect a DVM (digital voltmeter) across pins A and B of terminal board TB1 to monitor the displacement signal. Apply power to the system.
3. Position the permanent magnet at the specified null position. The null position is specified when the LDT assembly is ordered (typically 2 inches from the transducer head).
4. Use a screwdriver to adjust the *null potentiometer* (R20) clockwise to increase the value, or counterclockwise to decrease the value, until you obtain a DVM reading of 0.000 Vdc.
5. Position the permanent magnet for full-scale position (typically 5 or 7 inches from the end of the LDT assembly).
6. Use a screwdriver to adjust the *scale potentiometer* (R24) clockwise to increase the value, or counterclockwise to decrease the value, until you obtain a DVM reading of +10.000 Vdc.
7. Repeat steps 3 to 6 to check the null and full-scale settings. Readjust as necessary.
8. Disconnect the DVM and check overall system operation. If no more adjustments are necessary, replace the AOM cover.

Velocity Null Adjustment

Some AOM units are designed to provide velocity output. For those units, velocity null and velocity scale adjustments are provided. The velocity null and velocity scale adjustments are factory set and should not require readjustment. The velocity output signal represents a static displacement (no motion) by 0 volts and the maximum velocity of a dynamic displacement by 10 volts. The direction of motion is indicated by the polarity of the velocity signal; a positive signal normally indicates the permanent magnet is moving away from the transducer head (unless otherwise specified for this system).

The following procedure provides the velocity null adjustment; the velocity full-scale adjustment requires special equipment. Refer to Figure 2-2.

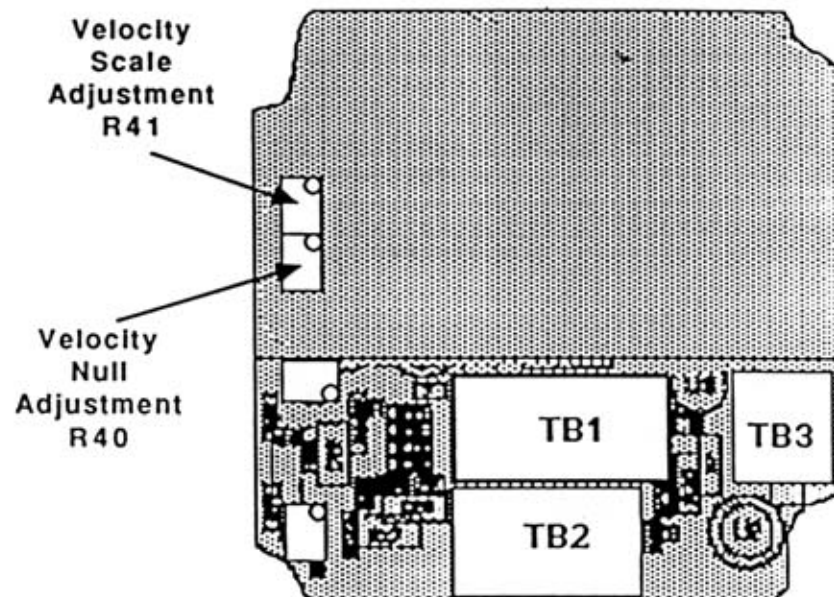

Figure 2-2. Velocity Adjustments on the AOM

NOTE

Velocity scale adjustment may be difficult in the field, because it requires precision equipment to control and measure the exact velocity.

1. Disconnect all power from the system. Loosen the four screws securing the AOM cover, and remove the cover.
2. Note the location of terminal board TB1 on the AOM (Refer to Figure 2-2). Connect a peak reading DVM (digital voltmeter) or oscilloscope across pins C and D of terminal board TB1 to monitor the velocity signal. Apply power to the system.
3. Make sure the permanent magnet is not moving.
4. Adjust the velocity null control (R40) clockwise to increase the value, or counterclockwise to decrease the value, until you obtain a DVM or oscilloscope reading of 0.000 Vdc.
5. Disconnect the DVM or oscilloscope and check overall system operation. If no more adjustments are necessary, replace the AOM cover.

3 Mounting Procedures

This section describes mounting procedures for the Linear Displacement Transducer measurement system, under the following headings:

- Installing the Analog Output Module
- Installing Rigid Transducers
- Installing Flexible Transducers
- Transducer Supports
- Spring Loading or Tensioning
- Cylinder Installation
- Installing Magnets

Specific installation procedures depend on the application.

Installing the Analog Output Module

Overall and mounting dimensions for the analog output module (AOM) are shown in Figure 3-1. The mounting hole dimensions shown are also stamped on the back of the module. The AOM is mounted as shown, using two socket head cap screws.

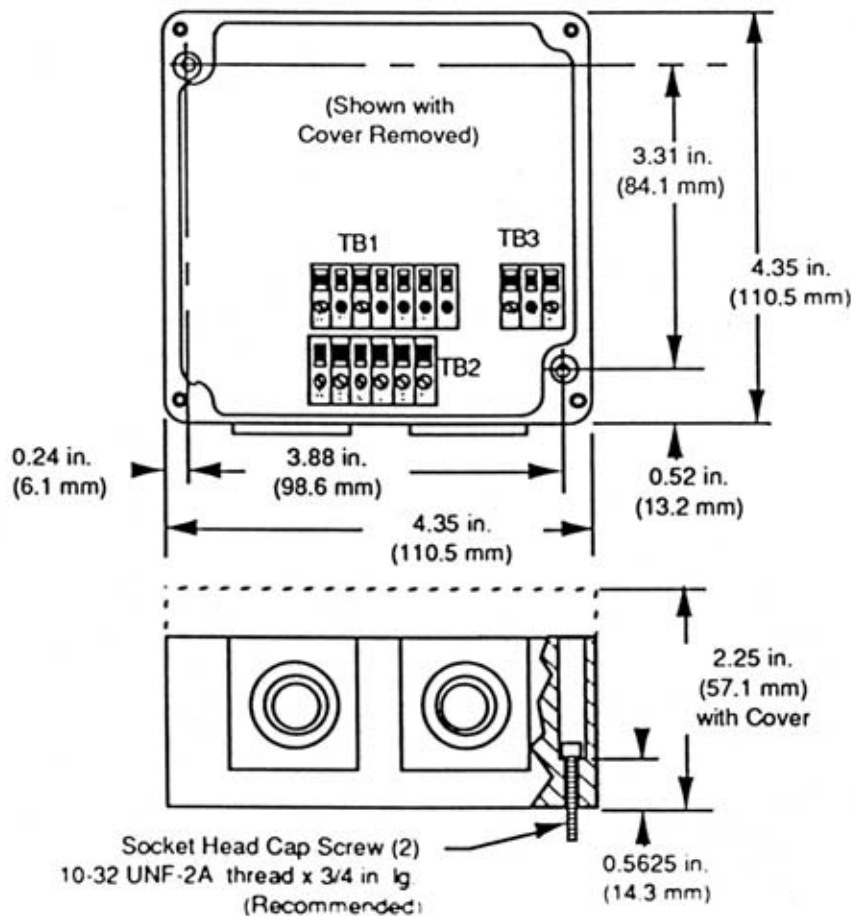

Figure 3-1 Overall Dimensions, AOM

Installing a Rigid Transducer

Before beginning installation, be sure you know the following dimensions(as illustrated in Figure 3-2):

- null space
- stroke
- dead zone

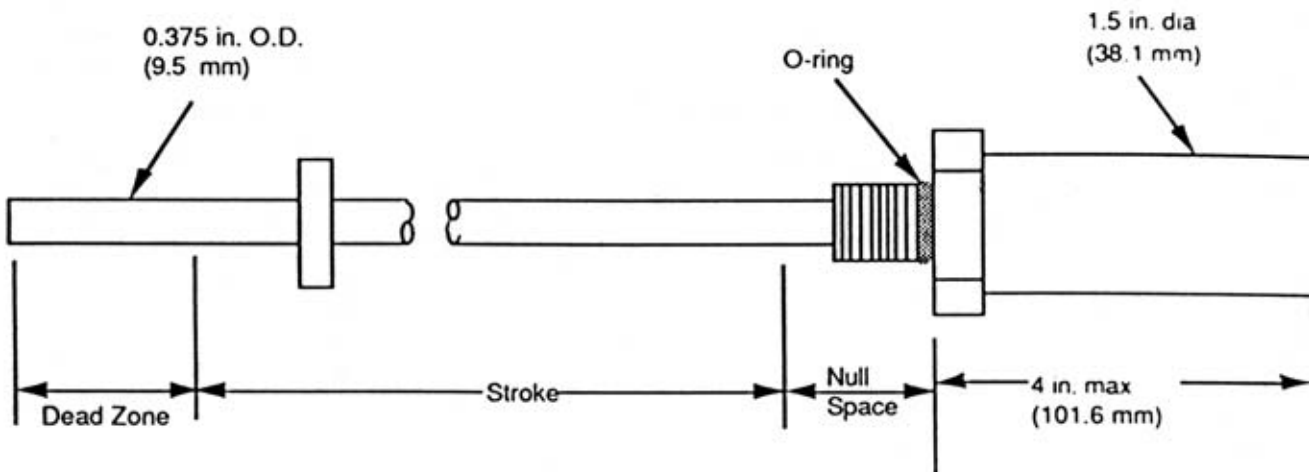
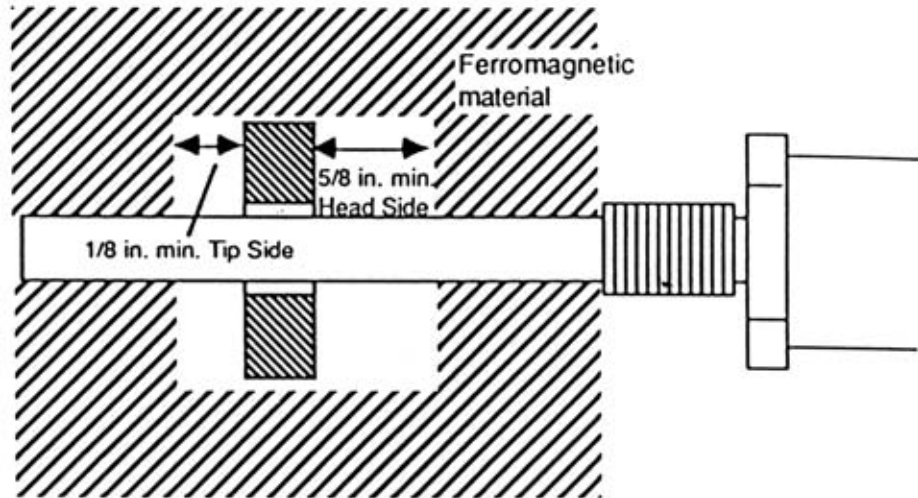

Figure 3-2. LDT Assembly

1. Use the 3/4 inches (19 mm), 16 UNF thread of the transducer to mount it at the selected location. Leave room to access the hex head. If a pressure or moisture seal is required, install an O-ring (type MS 28778-8 is recommended) in the special groove . Use the hex head to tighten the transducer assembly.
2. Install the permanent magnet over the LDT rod. Mount the permanent magnet to the movable device whose displacement will be measured. To minimize the effect of magnetic materials (i.e. iron, steel, etc) on the magnetic field of the permanent magnet, ensure the minimum spacing requirements are met as shown in Figure 3-3. (Any non-magnetic materials can be in direct contact with the permanent magnet without affecting performance.)

The magnet must not contact ferromagnetic materials (such as iron or steel). Clearances are required between the surface of the magnet and ferromagnetic material as shown. Non-ferrous material (such as copper, brass, or 300 series stainless steel) may contact the magnet without affecting transducer performance.



Standard null space is 2 inches. There is no maximum limit on null space. Less than 2 inches null space can be specified as long as magnet clearances are observed as shown above. The examples below illustrate minimum clearances.

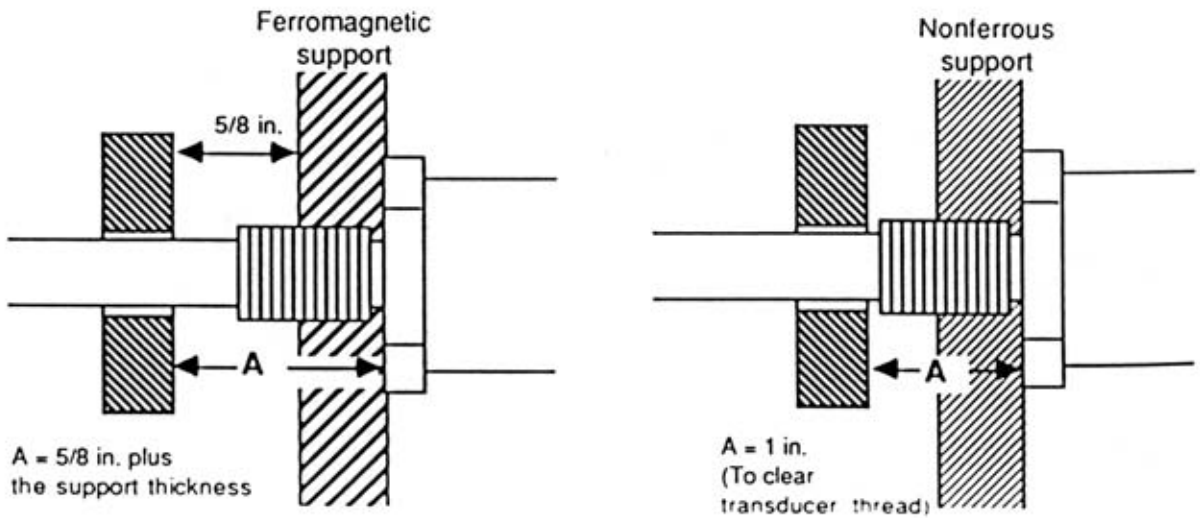

Figure 3.3 Magnetic Material Mounting Specifications

NOTE

Clearance between the magnet and the LDT rod is not critical. However, contact between the components will cause wear over time. The installation of supports or readjustment of the supports is recommended if the magnet contacts the LDT rod.

3. Move the permanent magnet full-scale to check that it moves freely. If not (if the magnet rubs on the LDT) you can correct this by mounting a support bracket to the end of the LDT. Long transducers may need additional supports to be attached to the transducer rod. Transducer supports are described later in this section.
4. Mount the analog output module in a location within reach of the LDT assembly cable. Standard systems allow the analog output module to be mounted 250 feet of the LDT assembly.
5. Connect the cable from the AOM to the transducer assembly.
6. Adjust the AOM null and full-scale potentiometers (as described in Section 2) to compensate for any offsets due to mechanical installation.

Installing a Flexible Transducer

Before beginning installation, be sure you know the following dimensions (as illustrated in Figure 3-4)

- null space
- stroke
- dead zone

Review the following considerations:

- Each flexible transducer is custom manufactured for a specific application and installation. The specific requirements (which are determined before ordering) include specific curvatures and straight sections at specific distances from the transducer head.
- A flexible transducer should not be subjected to temperatures above 130°F (54°C) unless specified. The temperature of the transducer rod should not vary more than ±30°F (±16°C) unless specified.
- A flexible transducer should not be subjected to pressures above atmospheric pressure.
- A flexible transducer can be flexed or curved to a standard diameter of 36 in. (91 cm) during installation. Consult MTS for specific applications.
- A flexible transducer requires supports or anchoring to maintain the designed shape. Transducer supports are described later in this section
- Some long transducers are ordered as flexible units to facilitate shipping and handling only, even though they are for straight applications.

CAUTION

DO NOT attempt to install a flexible transducer without knowing the design installation dimensions. Failure to follow the design dimensions can result in improper operation or transducer damage.

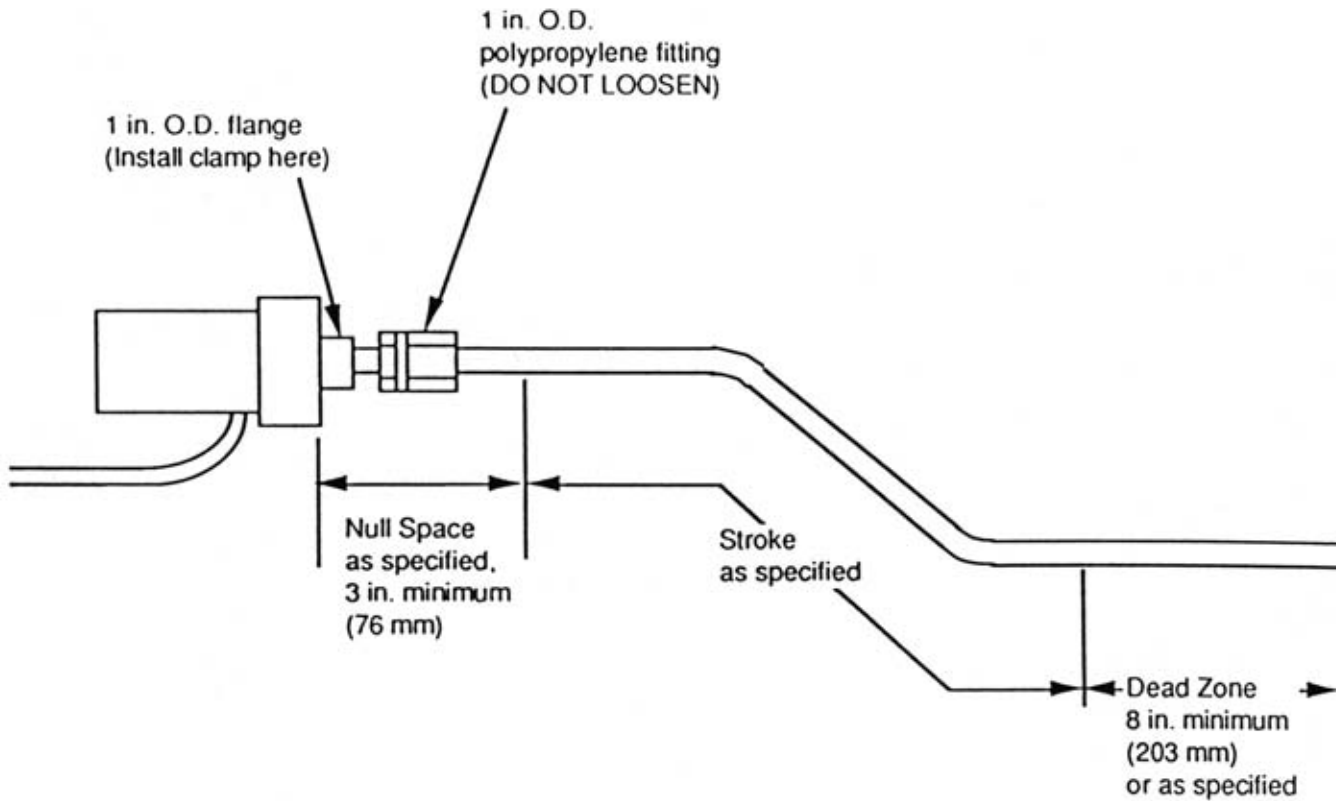

Figure 3-4. Flexible Transducer

Take the following steps to install a flexible transducer.

⚠ CAUTION

DO NOT loosen or mount the transducer using the polypropylene fitting near the transducer head. This will cause damage to the transducer.

1. A transducer supplied with a 1 inch O.D. head flange requires a U-bolt, flange collar or similar clamping device to keep the transducer head stationary.
2. Install the permanent magnet over the LDT rod. Mount the permanent magnet to the movable device whose displacement will be measured. To minimize the effect of magnetic materials (i.e. iron, steel, etc) on the magnetic field of the permanent magnet, ensure the minimum spacing requirements are met as shown in Figure 3-3. (Any non-magnetic materials can be in direct contact with the permanent magnet without affecting performance)
3. Mount the analog output module (AOM) in a location within reach of the LDT cable. Standard systems allow the AOM to be mounted a standard of 250 feet of the LDT assembly

4. Mount the required transducer supports. (Transducer supports are described later in this section.)
5. Connect the cable from the AOM to the transducer assembly.
6. Adjust the AOM null and full-scale potentiometers (as described in Section 2) to compensate for any offsets due to mechanical installation.

Types of Transducer Supports

Long transducers (4 feet or more) may require supports to maintain proper alignment between the transducer rod and the permanent magnet. All flexible transducers likewise require supports to obtain the design shape. When transducer rod supports are used, special permanent magnets are required.

Transducer supports attached to the active stroke length must be made of a non-ferrous material, thin enough to permit the permanent magnet to pass without obstruction. Because the permanent magnet does not enter the dead zone, supports connected within the dead zone may be made of any material. The main types of supports are loop, channel, and guide pipe supports.

Loop Supports

Loop supports are fabricated from non-ferrous materials, thin enough to permit free movement of the magnet. Loop supports are recommended for straight transducers. They may be used alone or with channel supports. Figure 3-5 illustrates the fabrication of a loop support.

NOTE

When open magnets are used, ensure the transducer rod remains within the inside diameter of the magnet throughout the length of the stroke. If the transducer rod is allowed to enter the cut out area of an open magnet, the transducer signal will be lost.

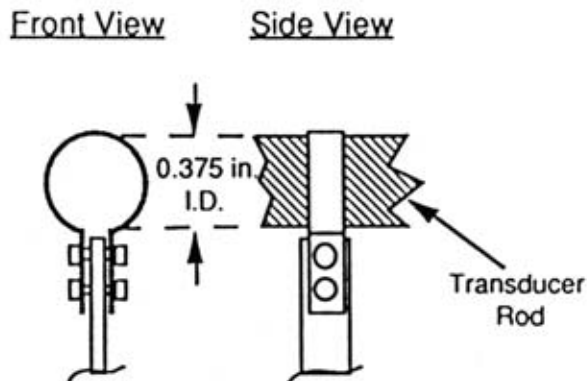

Figure 3-5. Loop Support

Channel Supports

Channel supports, being typically straight, are normally used with rigid transducers. A channel support consists of a straight channel with loop supports mounted at intervals. The loop supports are required to keep the transducer within the channel. Figure 3-6 shows a channel support. Channel supports are available from various manufacturers or may be fabricated.

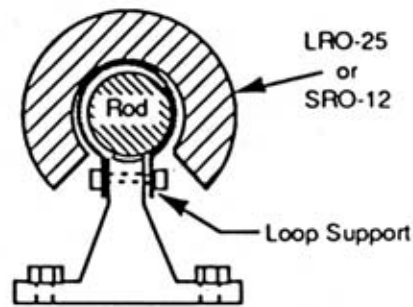

Figure 3-6. Channel Support

Guide Pipe Supports

Guide pipe supports are normally used for flexible transducers. A guide pipe support is constructed of non-ferrous material, straight or bent to the desired shape. As shown in Figure 3-7, both inside and outside dimensions of the pipe are critical:

- Because the transducer rod is installed inside the pipe, the inside diameter of the pipe must be large enough to clear the rod.
- The outside diameter of the pipe must be small enough to clear the magnet.

Refer to pipe manufacturers' specifications and dimensions (schedule 10, 40, etc) to select the appropriate size pipe. Guide pipe is typically supported at each end of the pipe.

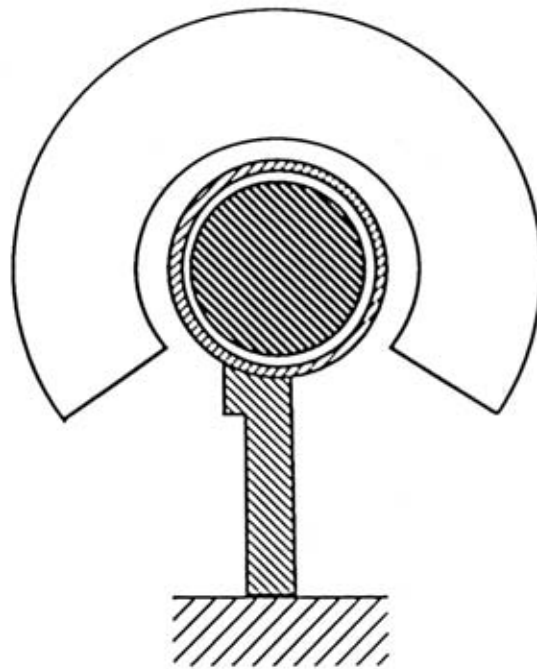

Figure. 3-7. Guide Pipe Support

Open Magnets

When using an open magnet, make sure the rod is positioned at all times within the "active" zone of the magnet. The transducer cannot operate properly unless the entire stroke of the transducer rod is located within this zone. The active zone, as shown in Figure 3-8, lies within the inside diameter of the magnet.

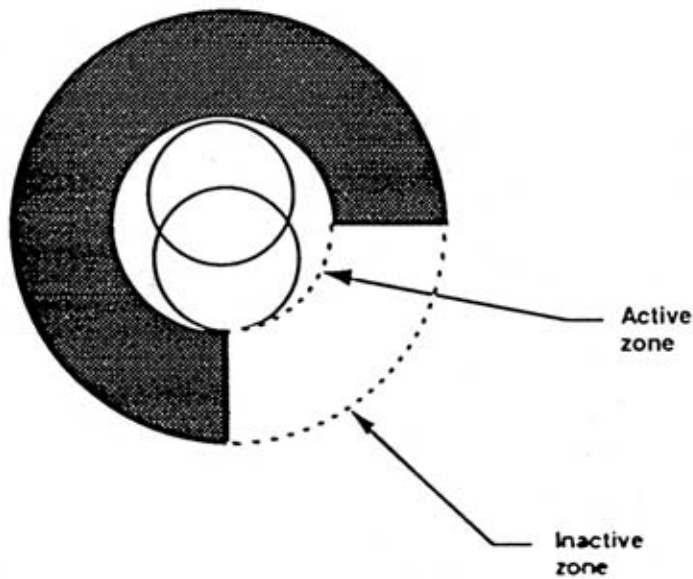

Figure 3-8. Active Zone for Open Magnets

Spring Loading or Tensioning

The transducer rod (flexible or rigid) can be spring loaded or tensioned using a stationary weight. Attach a spring mechanism or weight to the dead zone of the transducer rod with a clamping device which will not deform the transducer rod. The maximum weight or spring tension is 5 to 7 lbs. Spring loading or tensioning is recommended for vertical transducer installations.

Cylinder Installation

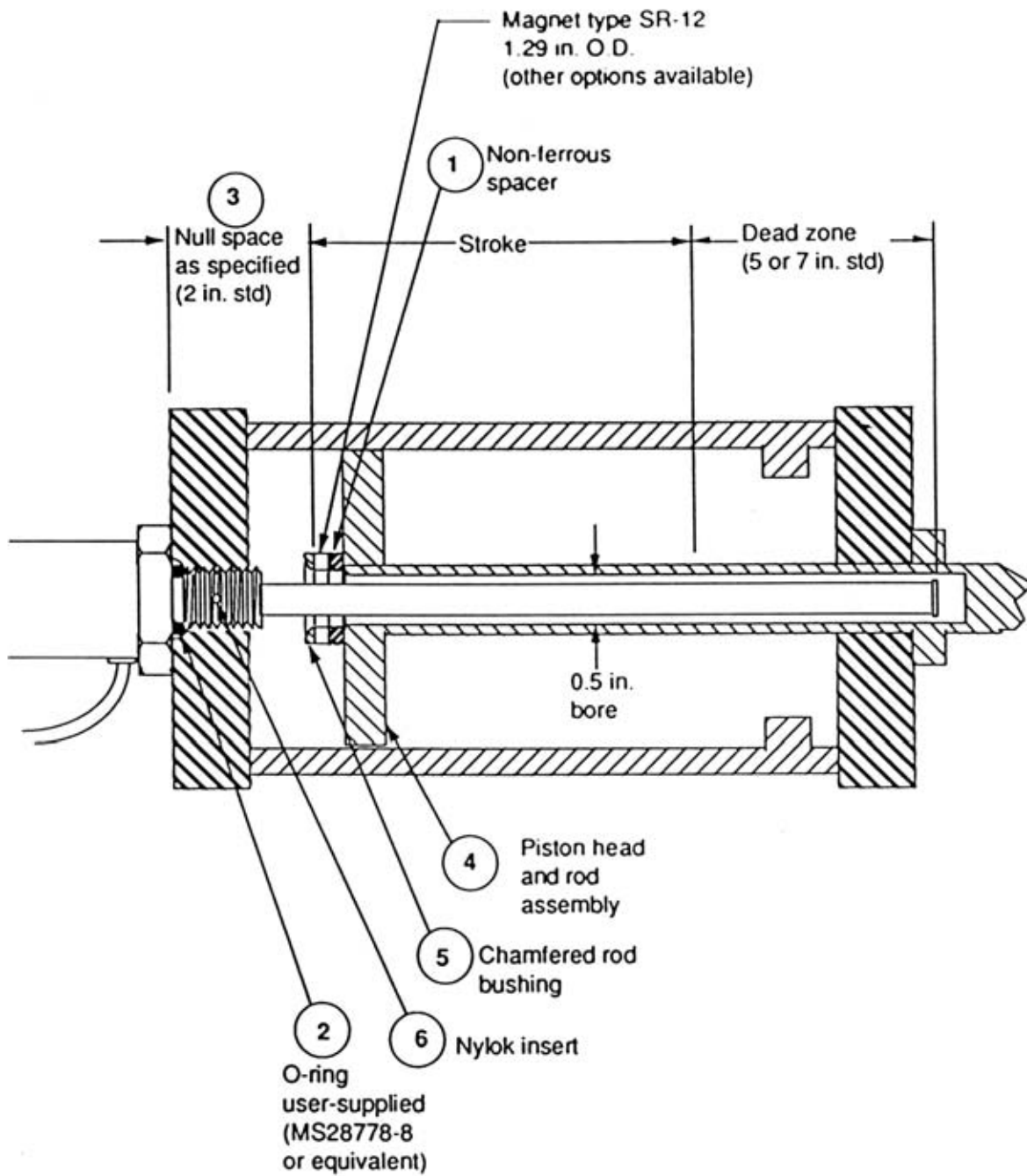

Figure 3-9. Typical Cylinder Installation

The rigid transducer installation procedure can be used as a guide for cylinder installations. Figure 3-9 shows a typical cylinder installation. Review the following before attempting this type of installation.

- Use a non-ferrous (plastic, brass, teflon, etc) spacer [1] to provide 1/8 inch (32 mm) minimum space between the magnet and the piston.
- An O-ring groove [2] is provided at the base of the transducer hex head for pressure sealing. MTS uses mil-standard MS33514 for the O-ring groove. Refer to mil-standard MS33649 or SAE J514 for machining of mating surfaces.
- The null space [3] is specified according to the installation design and cylinder dimensions. The analog output module provides a null adjustment. Make sure that the magnet can be mounted at the proper null position.
- The piston head [4] shown in Figure 3-9 is typical. For some installations, depending on the clearances, it may be desired to countersink the magnet.
- A chamfered rod bushing [5] should be considered for strokes over 5 feet (1.5 meters) to prevent wear on the magnet as the piston retracts. The bushing should be made from teflon or similar material.
- A nylok self locking insert [6] is provided on the transducer threads. An o-ring groove is provided at the base of the transducer hex head for pressure sealing.
- The recommended bore for the cylinder rod is 1/2 inch (13 mm). The transducer rod includes a .375 inch flush (12 mm) end plug; a flush end plug is available. Use standard industry practices for machining and mounting of all components. Consult the cylinder manufacturer for applicable SAE or military specifications.

Installing Magnets

If the null adjustment is inadequate, you can design a coupler with adjustments to mount the magnet to the measured member.

4 Wiring Procedures

This section describes general wiring procedures for the following types of analog output systems:

- 0 to 10 V displacement
- -10 to +10 V displacement
- Ungrounded 4 to 20 mA displacement
- Grounded 4 to 20 mA displacement

All other types of systems are described in Appendixes A and B at the back of this manual.

Connections are made between the transducer assembly, the analog output module (AOM), the customer-supplied power supply, and the customer-supplied receiving device.

Preparing Cable for Connection to the AOM

The AOM is equipped with two strain reliefs or two MS (mil-spec) connectors.

A strain relief is used for an unterminated cable. Prepare the cable as shown in Figure 4-1. It is recommended that you tin the exposed leads to ensure a good connection. Mount the cable to the AOM, ready to make connections to the terminal boards (TB1, TB2, or TB3) inside.

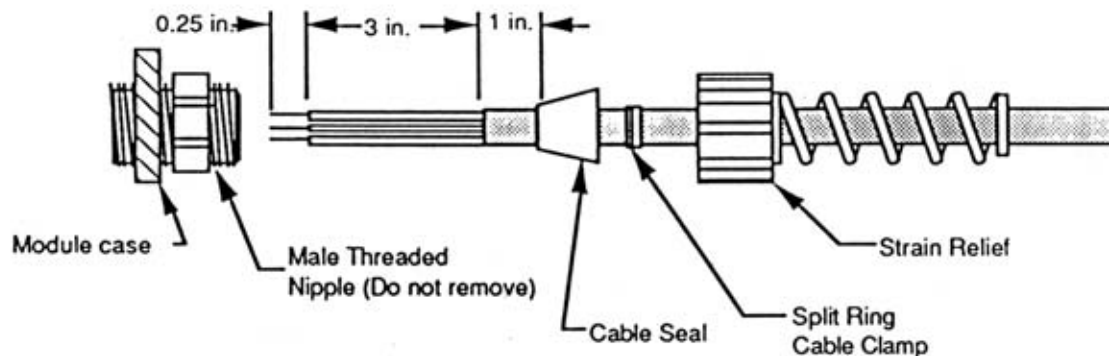

Figure 4-1. Cable Preparation for Strain Relief

When an MS connector is used, the correct matching connector is provided. In this case, strip and prepare the cable for soldering to the matching connector.

J1 Connections

The J1 cable provides the AOM voltage inputs from the customer-supplied power supply. It also provides displacement outputs to the customer-supplied receiving device.

Take the following steps to connect J1:

1. One of the screws securing the cover of the AOM has a raised head. Connect a ground wire from that screw head to a central earth ground or to the power supply ground (if it is grounded). Only one circuit earth ground should be used to prevent ground loops. (Refer to Figure 4-5 at the end of this section for a full system grounding diagram.)
2. **Strain Relief Only:** Fabricate the J1 cable, and prepare the cable as described earlier. Identify the connections to TB1 and TB3. Refer to Figure 4-2 (or 4-3 for velocity output) to determine the appropriate J1 connections.
3. **MS Connector Only:** Fabricate the J1 cable. Refer to Tables 4-1 through 4-3 to determine the appropriate J1 connections. Solder the connections to the type MS 3106 A 14S-5S connector supplied with the AOM. Use any cable capable of maintaining the signals for the required length. Ensure the solder connections are clean and free of excessive solder. Use heat-shrink over the solder connections to prevent the pins from shorting.
4. Identify the wires at the other end of cable for connections to the power supplies and the receiving device. Test the cable for shorts.

NOTE

Make sure that the power supply can provide +15 Vdc at 250 mA and -15 Vdc at 65 mA (use a bipolar power supply). The power supply should provide less than 1% ripple with 1% regulation. The power supply should be dedicated to the transducer system to prevent noise and external loads from affecting the system performance.

5. Make sure the power supply is off. Complete the cable connections at the power supply.

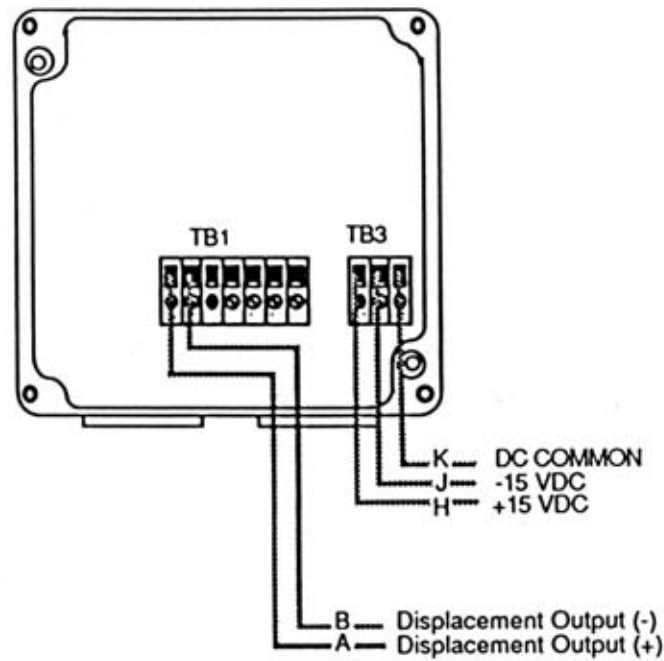

Figure 4-2. J1 Connections (Strain Relief)

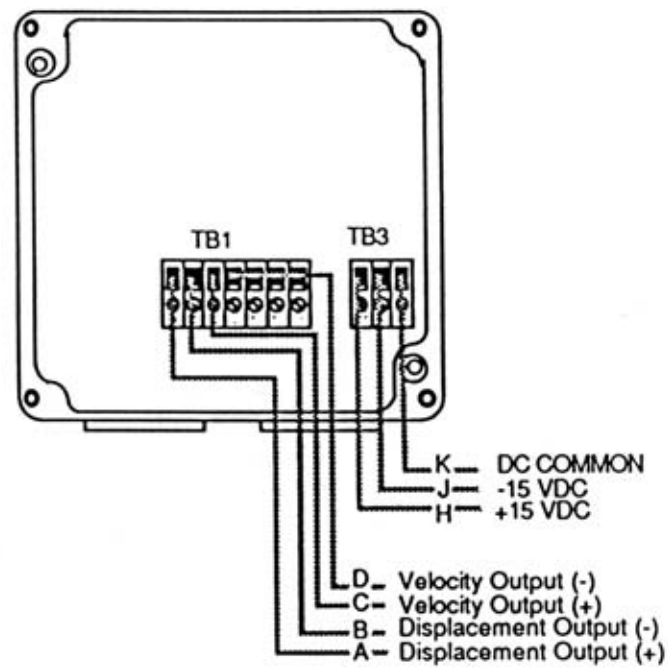

Figure 4-3. J1 Connections—Velocity Output (Strain Relief)

Table 4-1. Voltage Output J1 Connections (MS Connector)

J1 pin	Description
A	+15 Vdc
B	-15 Vdc
C	DC Common
D	Displacement
E	Optional output signals*

*Optional velocity or pulse-width modulated signal as second output.

Table 4-2. Ungrounded 4-20 mA Current Output J1 Connections (MS Connector)

J1 pin	Description
A	+15 Vdc
B	-15 Vdc
C	DC Common
D+	Current Output (source)*
E-	Current Output (return)*

*Do not ground or damage may result. Maximum load resistance: 400 Ω.

Table 4-3. Grounded 4-20 mA Current Output J1 Connections (MS Connector)

J1 pin	Description
A	+15 Vdc
B	-15 Vdc
C	DC Common and - Current (return)*
D+	+Current (source)
E-	(not connected)

*Maximum load resistance 500 Ω

CAUTION

The input to the receiver electronics should be a passive, resistive device to prevent damage to the AOM.

6. First, make sure there is no voltage present on the receiving device input connections. Then, complete the cable connections to the receiving device.

NOTE

Do not route the J1 cable near high voltage sources.

7. **Strain Relief Only:** Connect the cable to the TB1 and TB3 terminals on the AOM.
8. **MS Connector Only:** Connect the cable to the J1 connector on the AOM.

J2 Connections

The J2 cable provides connections between the AOM and the transducer assembly.

- Cables up to 20 ft (6 meters) can be fabricated with any high quality multiconductor cable with an overall shield (Belden equivalent).
- The recommended cable for 20 ft (6 meters) to 100 ft (30 meters) is Belden 9931 or Belden 83506 teflon (or equivalents).
- Cable lengths of 50 to 100 ft (15 to 30 meters) may need impedance matching. Consult the Sensors Division of MTS if operational problems are encountered.
- The recommended cable for 100 to 250 ft (30 to 75 meters) is Belden 9730 or equivalent. The transducer assembly must include the optional cable driver for this cable range.

NOTE

The blue cover of the transducer assembly is at circuit ground and should not be grounded locally

Take the following steps to connect J2:

1. It is recommended that you apply an earth ground to the transducer rod. This is typically accomplished by mounting the transducer head to a bracket or machine.
2. **Strain Relief Only:** If necessary, fabricate the J2 cable, and prepare the cable as described earlier. Identify the connections to TB2. Refer to Figure 4-4 for the J2 connections.

NOTE

Ensure the solder connections are clean and free of excessive solder. Use heat-shrink over the solder connections to prevent the pins from shorting.

3. **MS Connector Only:** If necessary, fabricate the J2 cable. Refer to Table 4-4 to determine the recommended mating connectors for the different transducers. Be sure to use the recommended cable for the required length. Refer to Table 4-5 for the appropriate J2 connections. The color code refers to cables supplied with the system. Solder the connections to the MS connector supplied with the AOM. Use any cable capable of maintaining the signals for the required length. Ensure the solder connections are clean and free of excessive solder. Use heat-shrink over the solder connections to prevent the pins from shorting.

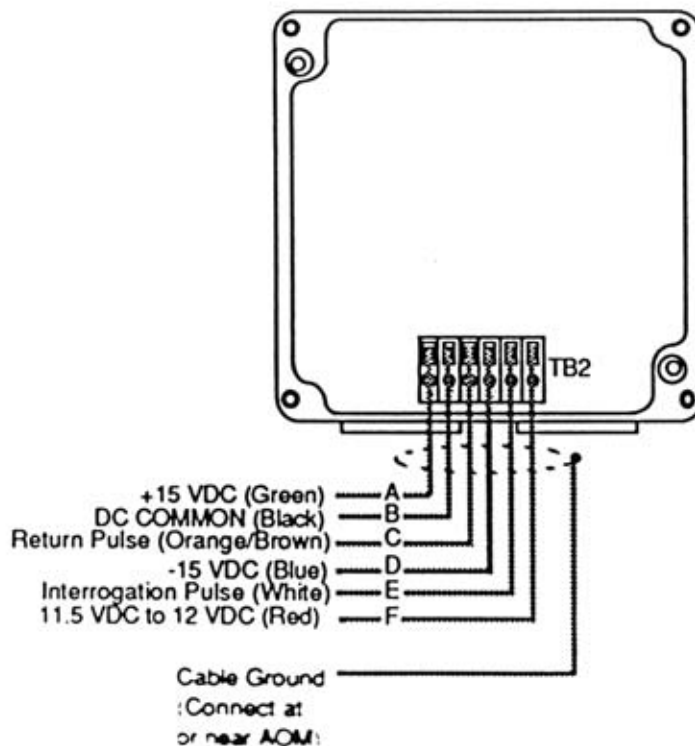
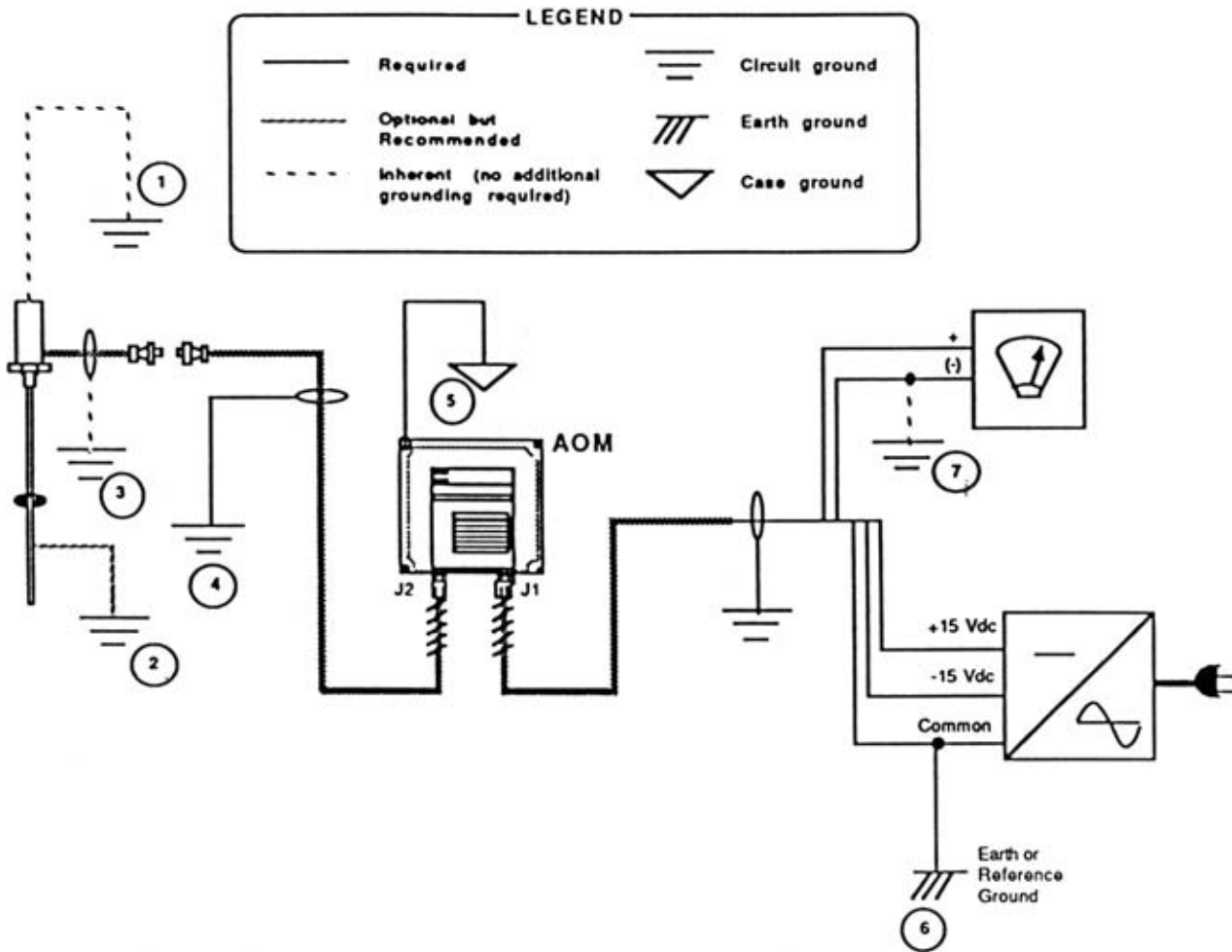

Figure 4-4 J2 Connections (Strain Relief)

4. **Strain Relief Only:** Connect the cable to the TB2 terminals on the AOM and to the transducer.
5. **MS Connector Only:** Connect the cable to the J2 connector on the AOM, and to the transducer.
6. **Apply power and check the displacement readings at the system electronics.**

Table 4-5. J2 Connections (MS Connector)

J2 Signal/Function	J2 Pin	Wire Color Code	Wire Color Code
		Integral Cable or Belden 9931 83506 Extension Cables	Belden 9730 wire/shield
+12 to +14.5 Vdc	A	Green	Black/Blue
DC Common/Ground	B	Black	Black/Red
Return pulse from transducer	C	Brown or Orange	Green/Blue
-13.5 to -14.5 Vdc	D	Blue	Black/Green
Interrogation Pulse to transducer	E	White	White/Green
+11.5 to +12Vdc transducer	F	Red	Red/Red
Cable Ground*		SHIELD - see below	
<p>* Cable Grounds:</p> <ol style="list-style-type: none"> 1. Cable shields are grounded at one end of the cable only. 2. An integral cable shield is connected to the circuit ground within the transducer head. 3. The extension cable shield should be connected to ground at the output module connector only. Apply ground by separate connection to earth ground or by connecting to pin B on the connector which mates to the box 			



1. Blue dust cover (NEMA 1) is at circuit ground. Do not apply additional ground. Stainless steel or aluminum ruggedized head cover (NEMA 4, NEMA 6) is at same potential as transducer rod.
2. (Optional) It is good practice to apply a machine, local, or earth ground to the transducer rod. This is normally accomplished by mounting to a grounded device.
3. Transducers with integral cable have circuit ground applied to the cable shield. The ground does not pass through the connector to the extension cable or AOM.
4. Connect extension cable shield to circuit ground or local earth ground at or near the AOM.
5. The AOM case is floating with respect to all grounds. It is good practice apply a local, earth or machine ground to this case. This is normally accomplished by mounting to a grounded device.
6. Circuit or "reference" ground is established by connecting the power supply common(s) to earth ground. Do not apply additional grounds to circuit ground (at the transducer head, integral cable shield, or analog output).
7. All voltage and 4–20 mA grounded outputs have circuit ground applied to the negative lead through the internal construction of the AOM. Circuit ground therefore passes to the receiver device (-) terminal. If the receiver device (-) is grounded, it must use the same ground that is applied to the power supply common.
8. For 4–20 mA ungrounded output only, the (-) lead of the AOM output must remain isolated from circuit ground (and earth ground) or output will malfunction. Do not connect to a device which has ground applied to the (-) terminal.

Figure 4-7 Grounding the Analog System

5 Troubleshooting

Use the troubleshooting procedures in this section when operational problems are encountered. The procedures are listed in order of frequency of occurrence, and should be completed in the order shown.

NOTE

The following procedures are for general diagnostic purposes. Purchase of replacement components should not be based solely on these procedures. Consult MTS Sensors Division for recommendations and factory service before ordering replacement components.

General

Make sure the magnet is positioned to move freely along the LDT rod. Trace all wiring from the J1 connector to ensure proper routing.

Power Supply Check

Perform the following procedure to check the power supply voltages.

1. Remove power and disconnect connector J1 to check open circuit power supply voltages (as described in steps 2 and 3).

NOTE

If voltage is not present in steps 2 and 3, a problem with wiring or the power supply is indicated.

2. Connect a DVM (digital voltmeter) to pins A and C of cable connector J1. Apply power. The voltage should be +15 Vdc.
3. Connect the DVM to pins B and C of cable connector J1. The voltage should be -15 Vdc.

NOTE

A low voltage reading in steps 4 and 5 indicates a power supply with an inadequate rating or an excessive voltage drop in the cabling (i.e. improper wire sizes).

4. If the voltage readings are correct, check the power supply voltages under load (as described in steps 5 and 6).
5. Connect a 60 Ω to 75 Ω resistor across pins A and C. The voltage across the resistor should be +14.7 Vdc (min).

6. Connect a 230 Ω to 250 Ω resistor across pins B and C. The voltage across the resistor should be -14.7 Vdc (min).

Grounding

Trace all ground and power supply common connections. A single earth ground should be connected to the power supply common (circuit ground). An additional ground is connected to the case of the analog output module (AOM). If the AOM is suspect, remove the mounting screws and place the box on insulating material (i.e. wood) then recheck the output readings.

Connections

Check the solder connections in the J1 cable. Ensure no cold solder joints are present. Perform a continuity check between the J1 connections to ensure no shorts are present.

LDT Signals

Disconnect connector J2 from the AOM. Apply power and check the J2 readings, using Figure 5-1 and earlier Table 4-5. If the voltages are correct, connect J2 and check the signals at pins B and C with an oscilloscope. If the J2 readings are proper, refer to step A. If the J2 readings are not proper, refer to step B.

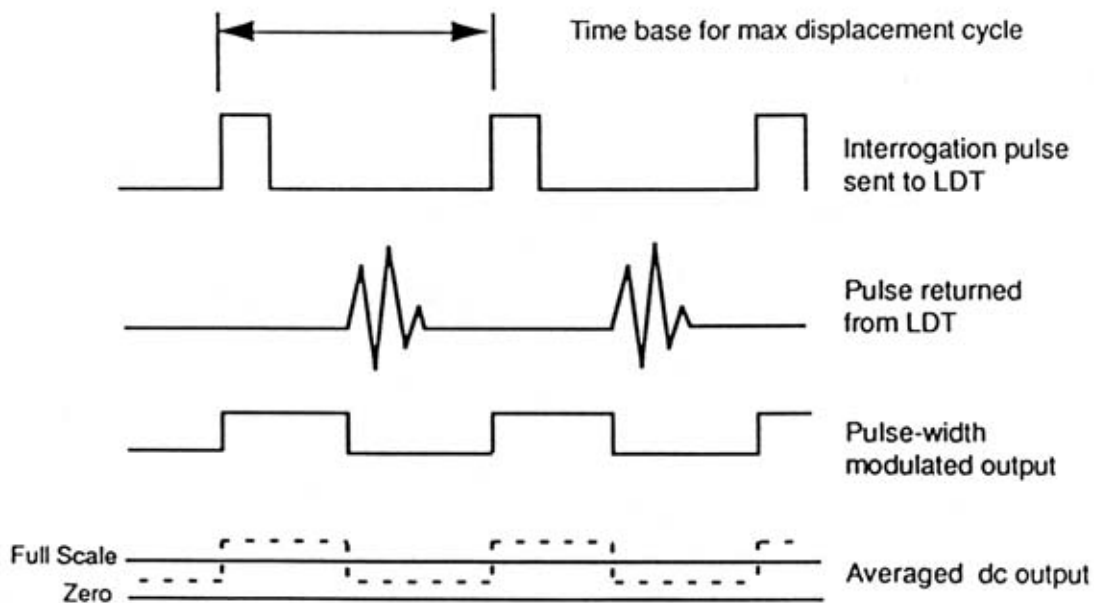

Figure 5-1 Analog Output Module Signals

NOTE

Do not interchange transducers and AOMs with differing model numbers, without first consulting MTS Sensors Division.

- A. If a spare transducer of the same stroke and model number is available, connect the spare transducer to the AOM and check the displacement readings at the system electronics.
- B. If a spare AOM of the same stroke model number is available, connect J1, J2 and the ground wire to the spare AOM and check the displacement readings at the system electronics.

Appendix A. J1 Wiring for Options

This appendix describes J1 wiring for non-standard options. J1 wiring includes all connections to TB1 and TB3. Table A-1 shows the TB1 connections for all available options. Wiring for the standard system (with displacement only) and for the velocity output option is illustrated in Section 4. Wiring for all other options is shown in Figures A-1 to A-4 below

Table A-1. TB1 Pins

Output Option	Signal Description	Terminal	Color Code
<i>Displacement Only (Voltage or Current)</i>	Displacement Output (+) Displacement Output (-)*	A B	
<i>Displacement and Velocity (Voltage or Current)</i>	Displacement Output (+) Displacement Output (-)* Velocity Output (+) Velocity Output (-)*	A B C D	
<i>Dual Channel Voltage</i>	Channel A Displacement Output (+) Channel A Displacement Output (-) Channel B Displacement Output (+) Channel B Displacement Output (-)	A B E F	
<i>Displacement Only with External Null or Scale Adjustment</i>	Displacement Output (+) Displacement Output (-)* (not connected) (not connected) Potentiometer Top (fully CW end) Potentiometer Wiper Potentiometer Bottom (fully CCW end)	A B C D E F G	
<i>Displacement and Velocity with External Null or Scale Adjustment</i>	Displacement Output (+) Displacement Output (-)* Velocity Output (+) Velocity Output (-) Potentiometer Top (fully CW end) Potentiometer Wiper Potentiometer Bottom (fully CCW end)	A B C D E F G	
*Normally at ground potential except for ungrounded current output options.			

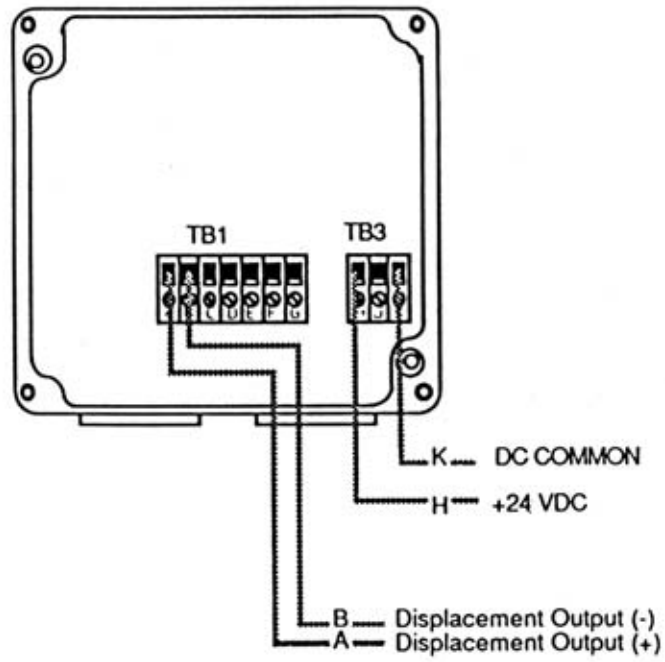

Figure A-1. J1 Connections—Displacement Only (24 Volt Option)

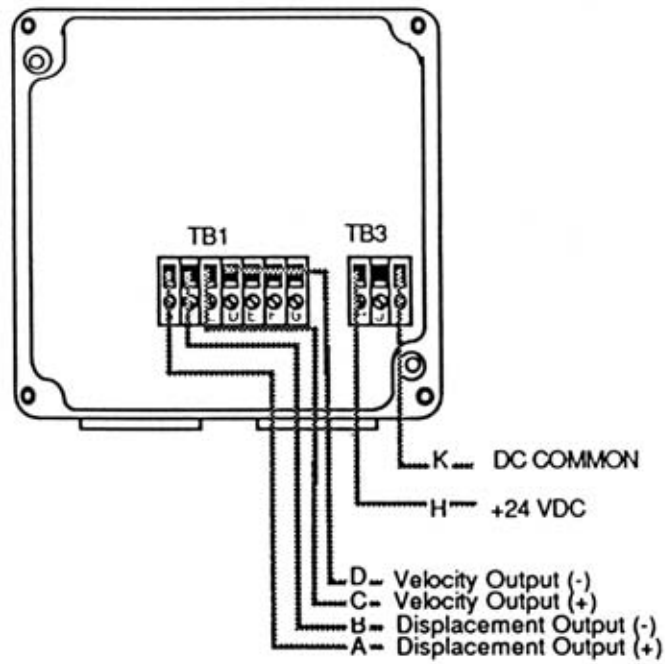

Figure A-2. J1 Connections—Velocity and Displacement (24 V Option)



**MTS SYSTEMS CORPORATION
SENSORS DIVISION**

BOX 13218
RESEARCH TRIANGLE PARK, NORTH CAROLINA 27709
TELEPHONE 919-677-0100 FAX 919-677-0200