

## Data Sheet

# E-Series EE Analog

## Magnetostrictive Linear Position Sensors

- Pressure-resistant sensor rod
- Compact sensor housing
- High operating temperature

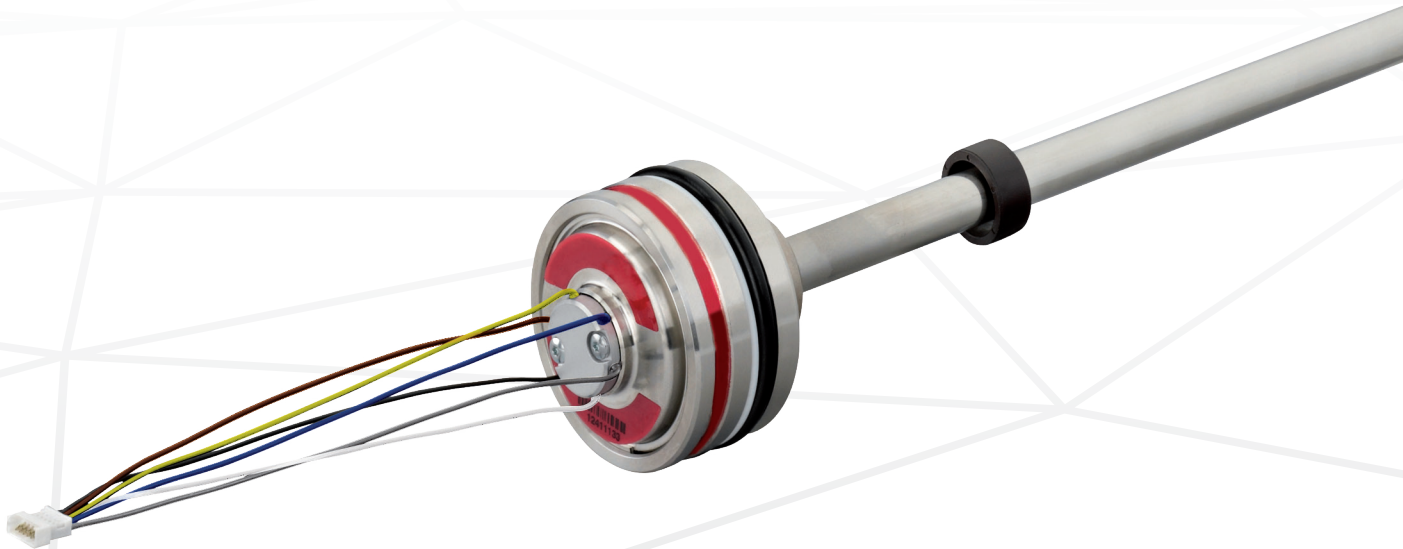

## MEASURING TECHNOLOGY

For position measurement, the absolute, linear Temposonics® position sensors make use of the properties offered by the specially designed magnetostrictive waveguide. Inside the sensor a torsional strain pulse is induced in the waveguide by momentary interaction of two magnetic fields. The interaction between these two magnetic fields produces a strain pulse, which is detected by the converter at the sensor electronics housing. One field is produced by a moving position magnet, which travels along the sensor rod with the waveguide inside. The other field is generated by a current pulse applied to the waveguide. The position of the moving magnet is determined precisely by measuring the time-of-flight between the application of the current pulse and the arrival of the strain pulse at the sensor electronics housing. The result is a reliable position measurement with high accuracy and repeatability.

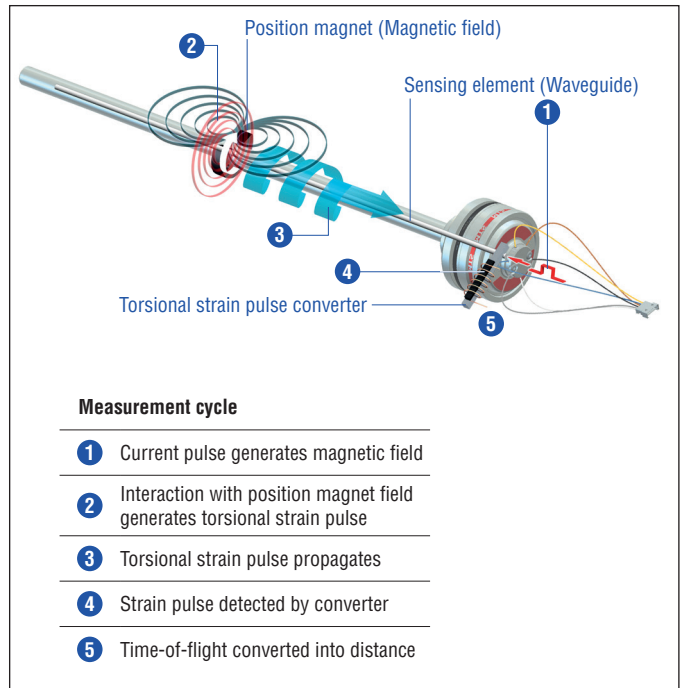

Fig. 1: Time-of-flight based magnetostrictive position sensing principle

## EE SENSOR

Robust, non-contact and wear free, the Temposonics® linear position sensors provide best durability and accurate position measurement solutions in harsh industrial environments. The position measurement accuracy is tightly controlled by the quality of the waveguide which is manufactured by Temposonics.

The Temposonics® E-Series EE position sensor is designed for the installation into a hydraulic cylinder. Because of his compact design the EE sensor is the perfect solution for small cylinders with limited space for the integration in a measuring system. The increased operating temperature capability allows the sensor to be used in a wide range of industrial applications.



Fig. 2: Typical application: Wood working

## TECHNICAL DATA

Output	
Current	4...20 mA or 20...4 mA (minimum/maximum load: 0/500 Ω)
Measured value	Position
Measurement parameters	
Resolution	Infinite
Cycle time	< 3 ms
Linearity <sup>1</sup>	< ±0.02 % F.S. (minimum ±60 μm)
Repeatability	< ±0.002 % F.S. (minimum ±20 μm)
Operating conditions	
Operating temperature	-40...+85 °C (-40...+185 °F)
Humidity	90 % rel. humidity, no condensation
Ingress protection	IP67 (if mating connectors are correctly fitted), sensor with flat connector IP30
Shock test	100 g (single shock)/IEC standard 60068-2-27
Vibration test	15 g/10...2000 Hz IEC standard 60068-2-6 (resonance frequencies excluded)
EMC test	Electromagnetic emission according to EN 55011, cl. B:2009 + A1:2010 Electromagnetic immunity according to EN 61326-1:2006 The sensor meets the requirements of the EU directives and is marked with <b>CE</b>
Magnet movement velocity	Any
Design/Material	
Sensor electronics housing	Stainless steel 1.4305 (AISI 303)
Sensor rod	Stainless steel 1.4306 (AISI 304L)
Stroke length	50...2540 mm (2...100 in.)
Operating pressure (Design H)	Up to 450 bar (6527 psi)
Operating pressure (Design S)	Up to 350 bar (5076 psi)
Mechanical mounting	
Mounting position	Any
Mounting instruction	Please consult the technical drawings and the operation manual (document number: <b>551415</b> )
Electrical connection	
Connection type	6 pin Molex PicoBlade™ connector system
Operating voltage	+24 VDC (-15/+20 %)
Ripple	≤ 0.28 Vpp
Current consumption	50...140 mA
Dielectric strength	500 VDC (0 V ground to machine ground)
Polarity protection	Up to -30 VDC
Overvoltage protection	Up to 36 VDC

<sup>1</sup>/ With position magnet # 201 542-2

TECHNICAL DRAWING

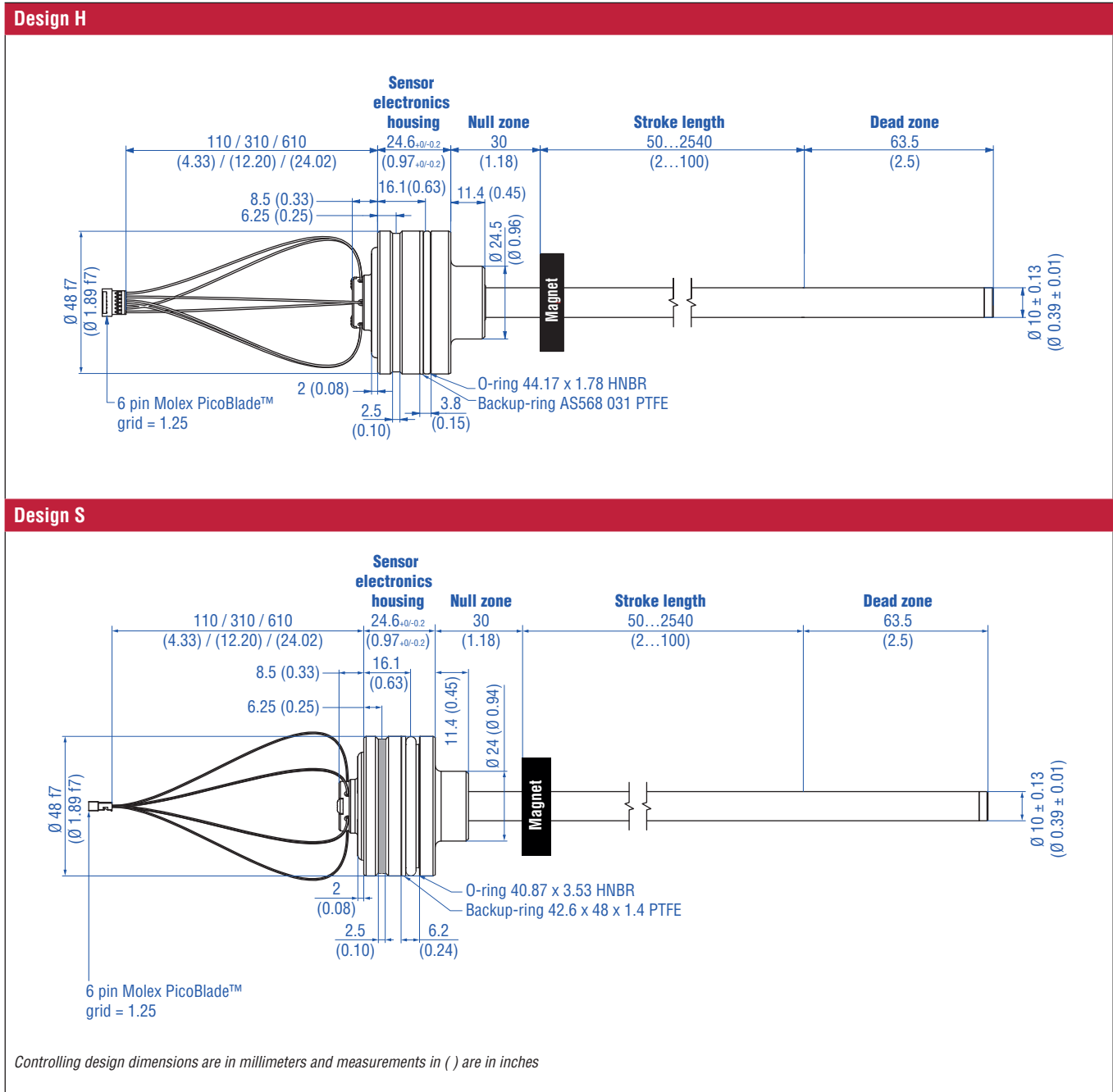

Fig. 3: Temposonics® E-Series EE Design H and Design S

## CONNECTOR WIRING

With mating connector cable 254 256 and 254 560		
5 pin connector	M12	Function
	Pin 1	+24 VDC (-15/+20 %)
	Pin 2	Output 1
	Pin 3	DC Ground (0 V)
	Pin 4	—
	Pin 5	DC Ground

Fig. 4: Connector wiring with mating connector cable 254 256 and 254 560

With extension cable 254 642-x			
6 pin Molex connector	Molex	Color	Function
	Pin 1	YE	—
	Pin 2	BL	—
	Pin 3	GY	Output 1
	Pin 4	WH	DC Ground (0 V)
	Pin 5	BK	DC Ground
	Pin 6	BN	+24 VDC (-15/+20 %)

Fig. 5: Connector wiring with extension cable 254 642-x

With mating connector cable 254 266			
6 pin Molex connector	Molex	Color	Function
	Pin 1	YE	—
	Pin 2	—	—
	Pin 3	GY	Output 1
	Pin 4	WH	DC Ground (0 V)
	Pin 5	BK	DC Ground
	Pin 6	BN	+24 VDC (-15/+20 %)

Fig. 6: Connector wiring with mating connector cable 254 266

**FREQUENTLY ORDERED ACCESSORIES** – Additional options available in our [Accessories Guide](#) 551444

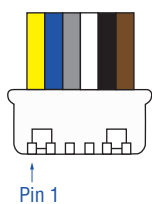
**Position magnets**

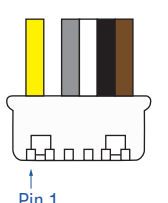
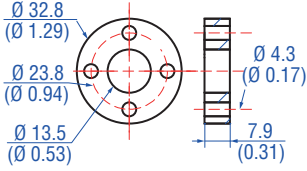

**Ring magnet OD33**  
Part no. 201 542-2

Material: PA ferrite GF20  
Weight: Approx. 14 g  
Surface pressure: Max. 40 N/mm<sup>2</sup>  
Fastening torque for M4 screws: 1 Nm  
Operating temperature:  
-40...+105 °C (-40...+221 °F)

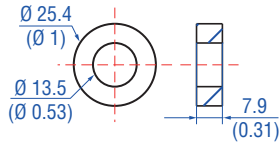

**Ring magnet OD25.4**  
Part no. 400 533

Material: PA ferrite  
Weight: Approx. 10 g  
Surface pressure: Max. 40 N/mm<sup>2</sup>  
Operating temperature:  
-40...+105 °C (-40...+221 °F)

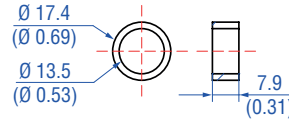

**Ring magnet OD17.4**  
Part no. 401 032

Material: PA neobond  
Weight: Approx. 5 g  
Surface pressure: Max. 20 N/mm<sup>2</sup>  
Operating temperature:  
-40...+105 °C (-40...+221 °F)

**Cable connectors<sup>2</sup>**

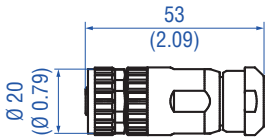

**M12 A-coded female connector**  
(4 pin/5 pin), straight  
Part no. 370 677

Material: GD-Zn, Ni  
Termination: Screw  
Contact insert: CuZn  
Cable Ø: 4...8 mm (0.16...0.31 in.)  
Wire: 1.5 mm<sup>2</sup>  
Operating temperature:  
-30...+85 °C (-22...+185 °F)  
Ingress protection: IP67 (correctly fitted)  
Fastening torque: 0.6 Nm

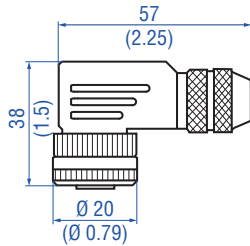

**M12 A-coded female connector**  
(5 pin), angled  
Part no. 370 678

Material: GD-Zn, Ni  
Termination: Screw; max. 0.75 mm<sup>2</sup>  
Contact insert: CuZn  
Cable Ø: 5...8 mm (0.2...0.31 in.)  
Wire: 0.75 mm<sup>2</sup> (18 AWG)  
Operating temperature:  
-25...+85 °C (-13...+185 °F)  
Ingress protection: IP67 (correctly fitted)  
Fastening torque: 0.4 Nm

**Mating connector cables**

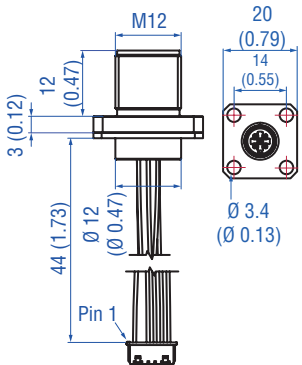

**5 pin mating connector cable M12**  
Part no. 254 256

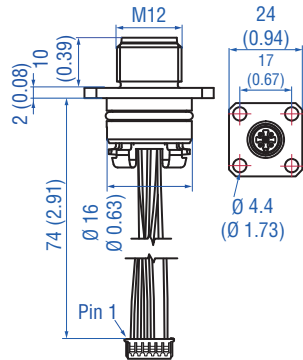

**5 pin mating connector cable M12**  
Part no. 254 560



**Extension cable Molex to Molex**  
140 mm: Part no. 254 642-1  
340 mm: Part no. 254 642-2  
640 mm: Part no. 254 642-3

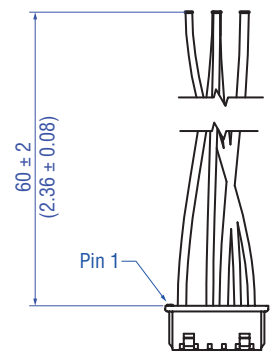

**Mating connector cable pigtail**  
Part no. 254 266

More information see 551758

<sup>2</sup> Follow the manufacturer's mounting instructions

Controlling design dimensions are in millimeters and measurements in ( ) are in inches

## ORDER CODE

1	2	3	4	5	6	7	8	9	10	11	12	13	14	15
E	E										1			
a		b	c					d			e	f		

<b>a</b>	<b>Sensor model</b>
E	E Rod

<b>b</b>	<b>Design</b>
H	Pressure fit flange, 10 mm rod-Ø (up to 450 bar (6527 psi))
S	Pressure fit flange, 10 mm rod-Ø (up to 350 bar (5076 psi))

<b>c</b>	<b>Stroke length</b>				
X	X	X	X	M	0050...2540 mm
<b>Standard stroke length (mm)</b>		<b>Ordering steps</b>			
50 ... 500 mm		5 mm			
500 ... 750 mm		10 mm			
750...1000 mm		25 mm			
1000...2540 mm		50 mm			
X	X	X	X	U	002.0...100.0 in.
<b>Standard stroke length (in.)</b>		<b>Ordering steps</b>			
2 ... 20 in.		0.2 in.			
20 ... 30 in.		0.5 in.			
30 ... 40 in.		1.0 in.			
40...100 in.		2.0 in.			
Non standard stroke lengths are available; must be encoded in 5 mm / 0.1 in. increments					

<b>d</b>	<b>Connection type</b>		
M	1	1	6 pin Molex PicoBlade™ connector system Cable length 110 mm
M	3	1	6 pin Molex PicoBlade™ connector system Cable length 310 mm
M	6	1	6 pin Molex PicoBlade™ connector system Cable length 610 mm

<b>e</b>	<b>Operating voltage</b>
1	+24 VDC (-15 / +20 %)

<b>f</b>	<b>Output</b>		
A	0	1	4...20 mA
A	1	1	20...4 mA

## DELIVERY



Sensor, O-ring,  
Backup-ring

Accessories have to be ordered  
separately.

Manuals, Software & 3D Models available at:  
[www.temposonics.com](http://www.temposonics.com)

\*/ Non standard stroke lengths are available; must be encoded in 5 mm / 0.1 in. increments



# Temposonics

AN AMPHENOL COMPANY

**Document Part Number:**  
551334 Revision E (EN) 07/2021

---

**UNITED STATES**  
**Temposonics, LLC**  
Americas & APAC Region  
3001 Sheldon Drive  
Cary, N.C. 27513  
Phone: +1 919 677-0100  
E-mail: [info.us@temposonics.com](mailto:info.us@temposonics.com)

---

**GERMANY**  
**Temposonics**  
**GmbH & Co. KG**  
EMEA Region & India  
Auf dem Schüffel 9  
58513 Lüdenscheid  
Phone: +49 2351 9587-0  
E-mail: [info.de@temposonics.com](mailto:info.de@temposonics.com)

---

**ITALY**  
Branch Office  
Phone: +39 030 988 3819  
E-mail: [info.it@temposonics.com](mailto:info.it@temposonics.com)

---

**FRANCE**  
Branch Office  
Phone: +33 6 14 060 728  
E-mail: [info.fr@temposonics.com](mailto:info.fr@temposonics.com)

---

**UK**  
Branch Office  
Phone: +44 79 21 83 05 86  
E-mail: [info.uk@temposonics.com](mailto:info.uk@temposonics.com)

---

**SCANDINAVIA**  
Branch Office  
Phone: + 46 70 29 91 281  
E-mail: [info.sca@temposonics.com](mailto:info.sca@temposonics.com)

---

**CHINA**  
Branch Office  
Phone: +86 21 2415 1000 / 2415 1001  
E-mail: [info.cn@temposonics.com](mailto:info.cn@temposonics.com)

---

**JAPAN**  
Branch Office  
Phone: +81 3 6416 1063  
E-mail: [info.jp@temposonics.com](mailto:info.jp@temposonics.com)

---



## temposonics.com

© 2021 Temposonics, LLC – all rights reserved. Temposonics, LLC and Temposonics GmbH & Co. KG are subsidiaries of Amphenol Corporation. Except for any third party marks for which attribution is provided herein, the company names and product names used in this document may be the registered trademarks or unregistered trademarks of Temposonics, LLC or Temposonics GmbH & Co. KG. Detailed trademark ownership information is available at [www.temposonics.com/trademarkownership](http://www.temposonics.com/trademarkownership).